

TM 9-2320-209-20-3-2

T.O. 36A12-1B-1092-1-3

TECHNICAL MANUAL
VOLUME 3 OF 3
PART 2 OF 4
MAINTENANCE
ORGANIZATIONAL LEVEL
2½-TON, 6x6, M44A1 AND M44A2 SERIES TRUCKS
(MULTIFUEL)
TRUCK, CARGO: M35A1,
M35A2, M35A2C, M36A2; TRUCK,
TANK, FUEL: M49A1C, M49A2C; TRUCK, TANK,
WATER: M50A1, M50A2, M50A3; TRUCK, VAN,
SHOP: M109A2, M109A3; TRUCK, REPAIR SHOP:
M185A2, M185A3; TRUCK, TRACTOR: M275A1,
M275A2; TRUCK, DUMP: M342A2; TRUCK,
MAINTENANCE, PIPELINE CONSTRUCTION:
M756A2; TRUCK, MAINTENANCE,
EARTH BORING AND POLESETTING: M764

Chapter 13
Brake System

Chapter 14
Wheel System

Chapter 15
Steering System

Chapter 16
Frame and Towing
Attachments

Chapter 17
Springs and
Shock Absorbers

NOTE:

THE STYLE OF THIS TM IS
EXPERIMENTAL. IT IS BEING TRIED
BY THE ARMY ONLY ON
A LIMITED BASIS

DEPARTMENTS OF THE ARMY AND THE AIR FORCE

MAY 1981

WARNING

EXHAUST GASES CAN BE DEADLY

Exposure to exhaust gases produces symptoms of headache, dizziness, loss of muscular control, apparent drowsiness, and coma. Permanent brain damage or death can result from severe exposure.

Carbon monoxide occurs in the exhaust fumes of fuel burning heaters and internal combustion engines, and becomes dangerously concentrated under conditions of inadequate ventilation. The following precautions must be observed to insure the safety of personnel whenever fuel burning heater(s) or engine of any vehicle is operated for maintenance purposes or tactical use.

Do not operate heater or engine of vehicle in an enclosed area unless it is adequately ventilated.

Do not idle engine for long periods without maintaining adequate ventilation in personnel compartments.

Do not drive any vehicle with inspection plates or cover plates removed unless necessary for maintenance purposes.

Be alert at all times during vehicle operation for exhaust odors and exposure symptoms. If either are present, immediately ventilate personnel compartments. If symptoms persist, remove affected personnel from vehicle and treat as follows: expose to fresh air; keep warm; do not permit physical exercise; if necessary, administer artificial respiration.

If exposed, seek prompt medical attention for possible delayed onset of acute lung congestion. Administer oxygen if available.

The best defense against exhaust gas poisoning is adequate ventilation.

WARNING

Serious or fatal injury to personnel may result if the following instructions are not complied with.

Dry cleaning solvent is flammable. Do not use near an open flame. Keep a fire extinguisher nearby when solvent is used. Use only in well-ventilated places. Failure to do this may result in injury to personnel and damage to equipment.

Be careful when taking out seals with a screwdriver. Screwdriver may slip and cause serious injury to personnel.

Do not dry bearings with compressed air. Spinning bearings may explode and cause serious injury to personnel.

Do not work on tire until all the air is out of it. Stand clear of retaining ring to avoid injury if the ring should fly off.

Be careful when inflating tire. Remounted tires should always be inflated in a safety cage. If a safety cage is not available, turn tire and rim over with outer hub side down.

Always wear leather gloves when handling cable. Do not let cable run through hands. If cable is frayed, sharp ends can go through leather glove and cause injury. Broken or rusty wires can cause serious injury to personnel.

WARNING - Cont

Keep hands away from wheels when jacking up truck. Wheels may turn as they clear the ground. Personnel can be injured.

When working on truck springs, keep body clear of underside of spring. When parts are taken off, spring may come out and cause injury.

Truck springs are under tension. Use C-clamp to hold spring together when taking it apart.

Truck springs are heavy. Make sure spring does not fall and cause injury to personnel and damage to equipment.

Clean hands carefully after using anti-seize compound. It contains lead and even small amounts will cause serious illness.

Do not use a wire brush or compressed air to clean brake drums. There may be asbestos dust on the drums which can be dangerous to your health.

*TM 9-2320-209-20-3-2

T.O. 36A12-1B-1092-1-3

TECHNICAL MANUAL
NO. 9-2320-209-20-3-2
TECHNICAL ORDER
NO. 36A12-1B-1092-1-3

DEPARTMENTS OF THE ARMY
AND
THE AIR FORCE
Washington, D. C., 27 May 1981

TECHNICAL MANUAL
VOLUME 3 OF 3
PART 2 OF 4
MAINTENANCE
ORGANIZATIONAL LEVEL
2½-TON 6X6, M44A1 AND M44A2 SERIES TRUCKS
(MULTIFUEL)

Model		NSN without Winch	NSN with Winch
Truck, Cargo	M35A1	2320-00-542-5633	2320-00-542-5634
	M35A2	2320-00-077-1616	2320-00-077-1617
	M35A2C	2320-00-926-0873	2320-00-926-0875
	M36A2	2320-00-077-1618	2320-00-077-1619
Truck, Tank, Fuel	M49A1C	2320-00-440-3349	2320-00-440-3346
	M49A2C	2320-00-077-1631	2320-00-077-1632
Truck, Tank, Water	M50A1	2320-00-440-8307	2320-00-440-8305
	M50A2	2320-00-077-1633	2320-00-077-1634
	M50A3	2320-00-937-4036	2320-00-937-5264
Truck, Van, Shop	M109A2	2320-00-440-8313	2320-00-440-8308
	M109A3	2320-00-077-1636	2320-00-077-1637
Truck, Repair Shop	M185A2	4940-00-987-8799	
	M185A3	4940-00-077-1638	4940-00-077-1639
Truck, Tractor	M275A1	2320-00-446-2479	
	M275A2	2320-00-077-1640	2320-00-077-1641
Truck, Dump	M342A2	2320-00-077-1643	2320-00-077-1644
Truck, Maintenance, Pipeline Construction	M756A2		2320-00-904-3277
Truck, Maintenance, Earth Boring and Polesetting	M764		2320-00-937-5980

*This manual, together with TM 9-2320-209-20-1, 27 May 1981; TM 9-2320-209-20-2-1, 27 May 1981; TM 9-2320-209-20-2-2, 27 May 1981; TM 9-2320-209-20-3-1, 27 May 1981; TM 9-2320-209-20-3-3, 27 May 1981; and TM 9-2320-209-20-3-4, 27 May 1981 supersedes TM 9-2320-209-20-1, 31 August 1978.

REPORTING OF ERRORS AND RECOMMENDING IMPROVEMENTS

You can help improve this manual. If you find any mistakes or if you know of a way to improve the procedure, please let us know. Mail your letter, DA Form 2028 (Recommended Changes to Publications and Blank Forms), or DA Form 2028-2 located in the back of this manual direct to: Commander, US Army Tank-Automotive Command, ATTN: DRSTA-MB, Warren, Michigan 48090. A reply will be furnished to you.

TABLE OF CONTENTS

	Paragraph	Page
CHAPTER 13. BRAKE SYSTEM GROUP MAINTENANCE		
Section I. Scope		13-1
Equipment Items Covered	13-1	13-1
Equipment Items Not Covered	13-2	13-1
Section II. Handbrake Assembly and Related Parts		13-1
Handbrake Brake Drum Removal and Replacement	13-3	13-1
Preliminary Procedure	13-3a	13-1
Removal	13-3b	13-2
Replacement	13-3c	13-6
Handbrake Brakeshoes Removal and Replacement	13-4	13-10
Removal	13-4a	13-10
Replacement	13-4b	13-14
Handbrake Cable Assembly Removal and Replacement	13-5	13-18
Preliminary Procedure	13-5a	13-18
Removal of Overcentering Locking Handbrake Lever Cable	13-5b	13-18
Removal of Ratchet and Pawl Handbrake Lever Cable	13-5c	13-23
Replacement of Overcenter Locking Handbrake Lever Cable	13-5d	13-27
Replacement of Ratchet and Pawl Handbrake Lever Cable	13-5e	13-32
Handbrake Lever Assembly Removal and Replacement	13-6	13-37
Removal	13-6a	13-37
Replacement	13-6b	13-40
Handbrake Cable and Lever Assembly Adjustment	13-7	13-43
Section III. Service Brake		13-49
Service Brakeshoe Assembly Removal and Replacement	13-8	13-49
Preliminary Procedure	13-8a	13-49
Removal	13-8b	13-49
Replacement	13-8c	13-54

TABLE OF CONTENTS-CONT

	Paragraph	Page
	Service Brakes Minor Adjustment	13-9 13-61
	Service Brakes Major Adjustment	13-10 13-63
Section IV.	Hydraulic Brake System	13-73
	Hydraulic Wheel Cylinder Removal and	
	Replacement	13-11 13-73
	Preliminary Procedure	13-11a 13-73
	Removal	13-11b 13-73
	Replacement	13-11c 13-75
	Master Cylinder Assembly Removal and	
	Replacement	13-12 13-78
	Removal	13-12a 13-78
	Replacement	13-12b 13-83
	Hydraulic Lines, Hoses, and Fittings	
	Removal and Replacement	13-13 13-87
	Removal	13-13a 13-88
	Replacement	13-13b 13-97
	Air Hydraulic Cylinder Removal and	
	Replacement	13-14 13-107
	Preliminary Procedure	13-14a 13-107
	Removal	13-14b 13-107
	Replacement	13-14c 13-112
	Bleeding Service Brake System Using	
	Bleeder Tank	13-15 13-117
	Connecting Bleeding Tank	13-15a 13-117
	Bleeding Air Hydraulic Cylinder	13-15b 13-120
	Bleeding Wheel Cylinders	13-15c 13-122
	Disconnecting Bleeder Tank	13-15d 13-124
	Bleeding Service Brake System Without	
	Using Bleeder Tank	13-16 13-127
	Filling Master Cylinder	13-16a 13-127
	Bleeding Air Hydraulic Cylinder	13-16b 13-128
	Bleeding Wheel Cylinders	13-16c 13-131
Section V.	Mechanical Brake System	13-134
	Brake Pedal Removal and Replacement	13-17 13-134
	Preliminary Procedure	13-17a 13-134
	Removal	13-17b 13-134
	Replacement	13-17c 13-139
	Brake Pedal Pad Removal and Replacement	13-18 13-144
	Removal	13-18a 13-144
	Replacement	13-18b 13-145
	Service Brake Pedal Adjustment	13-19 13-146
Section VI.	Air Brake System	13-148
	Vent Air System Pressure	13-20 13-148
	Air System Lines and Fittings	13-21 13-149
	Preliminary Procedure	13-21a 13-149
	Removal	13-21b 13-150
	Replacement	13-21c 13-156

TABLE OF CONTENTS-CONT

	Paragraph	Page
Air Brake Valve Removal and Replacement	13-22	13-162
Preliminary Procedure	13-22a	13-162
Removal	13-22b	13-162
Replacement	13-22c	13-164
Air Brake Hand Control Valve Repair	13-23	13-166
Removal	13-23a	13-166
Replacement	13-23b	13-168
Air Brake Hand Control Valve Removal and Replacement	13-24	13-170
Removal	13-24a	13-170
Replacement	13-24b	13-174
Air System Safety Valve Removal and Replacement	13-25	13-180
Preliminary Procedures	13-25a	13-180
Removal	13-25b	13-181
Replacement	13-25c	13-182
Air Reservoirs Removal and Replacement (Trucks M275A1, M2725A2, and M342A2)	13-26	13-183
Preliminary Procedures	13-26a	13-183
Removal	13-26b	13-183
Replacement	13-26c	13-187
Air Reservoirs Removal and Replacement (Trucks M49A1C and M49A2C)	13-27	13-191
Preliminary Procedures	13-27a	13-191
Removal	13-27b	13-191
Replacement	13-27c	13-197
Air Reservoirs Removal and Replacement (Trucks M35A2C , M50A2, M109A3, M185A3 and M756A2)	13-28	13-203
Preliminary Procedures	13-28a	13-203
Removal	13-28b	13-203
Replacement	13-28c	13-210
Air Reservoirs Removal and Replacement (Truck M764)	13-29	13-217
Preliminary Procedures	13-29a	13-217
Removal	13-29b	13-217
Replacement	13-29c	13-223
Air Reservoirs Removal and Replacement (Truck M35A1)	13-30	13-229
Preliminary Procedures	13-30a	13-229
Removal	13-30b	13-229
Replacement	13-30c	13-233
Section VII. Compressed Air System		13-237
Air Compressor Removal and Replacement	13-31	13-237
Preliminary Procedures	13-31a	13-237
Removal	13-31b	13-238
Replacement	13-31c	13-242

TABLE OF CONTENTS-CONT

	Paragraph	Page
Air Compressor Service	13-32	13-247
Preliminary Procedure	13-32a	13-247
Removal	13-32b	13-247
Disassembly and Service	13-32c	13-248
Assembly	13-32d	13-249
Replacement	13-32e	13-250
Air Compressor Belt and Pulley Removal and Replacement	13-33	13-251
Preliminary Procedures	13-33a	13-251
Removal	13-33b	13-252
Replacement	13-33c	13-254
Air Compressor Drive Belt Removal, Replacement, and Adjustment	13-34	13-258
Preliminary Procedures	13-34a	13-258
Removal	13-34b	13-258
Replacement and Adjustment	13-34c	13-259
Air Compressor Governor Assembly Removal and Replacement	13-35	13-260
Preliminary Procedures	13-35a	13-260
Removal	13-35b	13-260
Replacement	13-35c	13-262
Air Compressor Governor Pressure Check and Adjustment	13-36	13-264
Pressure Check	13-36a	13-264
Adjustment (Air Pressure More Than 105 psi)	13-36b	13-265
Adjustment (Air Pressure Less Than 105 psi)	13-36c	13-266
Section VIII. Trailer Brake Connections		13-267
Quick Disconnect Coupling Half Removal and Replacement	13-37	13-267
Preliminary Procedures	13-37a	13-267
Removal	13-37b	13-267
Replacement	13-37c	13-268
Quick Disconnect Coupling Half Repair	13-38	13-269
Air Brake Cutoff Cocks and Couplings Removal and Replacement (All Trucks Except M764)	13-39	13-270
Preliminary Procedures	13-39a	13-270
Removal	13-39b	13-271
Replacement	13-39c	13-273
Air Brake Cutoff Cocks and Couplings Removal and Replacement (Truck M764)	13-40	13-275
Preliminary Procedures	13-40a	13-275
Removal	13-40b	13-276
Replacement	13-40c	13-277

TABLE OF CONTENTS -CONT

	Paragraph	Page
Air Brake Hose Removal and Replacement	13-41	13-278
Preliminary Procedure	13-41a	13-278
Removal	13-41b	13-278
Replacement	13-41c	13-281
Air Brake Hose Repair	13-42	13-283
Preliminary Procedure	13-42a	13-283
Repair	13-42b	13-283
CHAPTER 14. WHEEL GROUP MAINTENANCE		
Section I. Scope		14-1
Equipment Items Covered	14-1	14-1
Equipment Items Not Covered	14-2	14-1
Section II. Front Wheel Assembly		14-1
Front Wheel and Brake Drum Assembly		
Removal and Replacement	14-3	14-1
Preliminary Procedure	14-3a	14-1
Removal	14-3b	14-1
Replacement	14-3c	14-6
Front Hub and Brake Drum Assembly		
Removal and Replacement	14-4	14-11
Preliminary Procedure	14-4a	14-11
Removal	14-4b	14-11
Replacement	14-4c	14-15
Front and Rear Hub and Brake Drum		
Assembly Repair	14-5	14-20
Preliminary Procedure	14-5a	14-20
Front Hub and Brake Drum	14-5b	14-20
Rear Hub and Brake Drum... ..	14-5c	14-26
Front Wheel Bearing Cover and Seals		
Removal and Replacement for Service	14-6	14-32
Preliminary Procedure	14-6a	14-32
Removal	14-6b	14-32
Cleaning	14-6c	14-33
Inspection	14-6d	14-34
Lubrication	14-6e	14-35
Replacement	14-6f	14-36
Front Inner and Outer Wheel Bearings		
and Seals Removal and Replacement	14-7	14-37
Preliminary Procedure	14-7a	14-37
Removal	14-7b	14-37
Cleaning	14-7c	14-40
Inspection	14-7d	14-41
Lubrication	14-7e	14-42
Replacement	14-7f	14-43
Section III. Rear Wheel Assembly		14-46
Rear Wheels and Brake Drum Assembly		
Removal and Replacement	14-8	14-46
Preliminary Procedure	14-8a	14-46
Removal	14-8b	14-46
Replacement	14-8c	14-50

TABLE OF CONTENTS-CONT

	Paragraph	Page
Rear Hub and Brake Drum Assembly		
Removal and Replacement	14-9	14-55
Preliminary Procedure	14-9a	14-55
Removal	14-9b	14-55
Replacement	14-9c	14-59
Rear Inner and Outer Wheel Bearings and		
Seals Removal and Replacement	14-10	14-64
Preliminary Procedure	14-10a	14-64
Removal	14-10b	14-64
Cleaning	14-10c	14-67
Inspection	14-10d	14-68
Lubrication	14-10e	14-69
Replacement	14-10f	14-70
Rear Wheel Bearing Cones and Seals		
Removal and Replacement for Service	14-11	14-73
Preliminary Procedure	14-11a	14-73
Removal	14-11b	14-73
Cleaning	14-11c	14-74
Inspection	14-11d	14-75
Lubrication	14-11e	14-76
Replacement	14-11f	14-77
Section IV. Tires		14-78
Tire and Tube	14-12	14-78
Preliminary Procedure	14-12a	14-78
Removal	14-12b	14-78
Replacement	14-12c	14-83
CHAPTER 15. STEERING SYSTEM GROUP MAINTENANCE		
Section I. Scope		15-1
Equipment Items Covered	15-1	15-1
Equipment Items Not Covered	15-2	15-1
Section II. Mechanical Steering Gear Assembly		15-1
Front Wheel Alinement	15-3	15-1
Preliminary Procedures	15-3a	15-1
Toe-in Check and Adjustment	15-3b	15-2
Pitman Arm Removal and Replacement	15-4	15-8
Removal	15-4a	15-8
Replacement	15-4b	15-10
Steering Gear Adjustment	15-5	15-12
Preliminary Procedure	15-5a	15-12
Adjustment	15-5b	15-12
Tie Rod End Removal and Replacement	15-6	15-18
Preliminary Procedure	15-6a	15-18
Removal	15-6b	15-18
Replacement	15-6c	15-20
Drag Link Assembly Removal and		
Replacement	15-7	15-22
Preliminary Procedure	15-7a	15-22
Removal	15-7b	15-22
Replacement	15-7c	15-25

TABLE OF CONTENTS-CONT

	Paragraph	Page
Drag Link Assembly Repair	15-8	15-29
Drag Link Adjustment	15-9	15-30
Steering Wheel Removal and Replacement	15-10	15-31
Preliminary Procedures	15-10a	15-31
Removal	15-10b	15-32
Replacement	15-10c	15-35
CHAPTER 16. FRAME AND TOWING ATTACHMENTS GROUP MAINTENANCE		
Section I. Scope		16-1
Equipment Items Covered	16-1	16-1
Equipment Items Not Covered	16-2	16-1
Section II. Pintle and Towing Attachments		16-1
Front Lifting Shackle Removal and Replacement	16-3	16-1
Preliminary Procedure	16-3a	16-1
Removal	16-3b	16-2
Replacement	16-3c	16-5
Rear Lifting Shackle Removal and Replacement	16-4	16-8
Removal	16-4a	16-8
Replacement	16-4b	16-9
Pintle Hook Removal and Replacement	16-5	16-10
Removal	16-5a	16-10
Replacement	16-5b	16-11
Pintle Hook Repair	16-6	16-12
Preliminary Procedure	16-6a	16-12
Disassembly	16-6b	16-12
Assembly	16-6c	16-15
Section III. Spare Wheel Carrier		16-17
Spare Wheel Carrier Removal and Replacement (All Trucks Except (M342A2)	16-7	16-17
Preliminary Procedures	16-7a	16-17
Removal	16-7b	16-18
Replacement	16-7c	16-19
Spare Wheel Carrier Repair (All Trucks Except Truck M342A2)	16-8	16-20
Preliminary Procedure	16-8a	16-20
Disassembly	16-8b	16-20
Assembly	16-8c	16-23
Spare Wheel Carrier Removal and Replacement (Truck M342A2)	16-9	16-25
Preliminary Procedure	16-9a	16-25
Removal	16-9b	16-25
Replacement	16-9c	16-29
Spare Wheel Carrier Repair (Truck M342A2)... Preliminary Procedure	16-10	16-34
Disassembly	16-10a	16-34
Repair	16-10b	16-34
Assembly	16-10c	16-41
Repair	16-10c	16-41
Assembly	16-10d	16-41

TABLE OF CONTENTS-CONT

	Paragraph	Page
Section IV. Fifth Wheel Assembly		16-48
Fifth Wheel Assembly Removal and		
Replacement	16-11	16-48
Removal	16-11a	16-48
Replacement	16-11b	16-51
CHAPTER 17. SPRINGS AND SHOCK ABSORBERS GROUP		
MAINTENANCE		
Section I. Scope		17-1
Equipment Items Covered	17-1	17-1
Equipment Items Not Covered	17-2	17-1
Section II. Springs		17-1
Front Springs Removal and Replacement	17-3	17-1
Removal	17-3a	17-2
Replacement	17-3b	17-6
Front Leaf Spring Assembly Repair	17-4	17-14
Preliminary Procedure	17-4a	17-14
Disassembly	17-4b	17-15
Cleaning, Inspection, and Repair.	17-4c	17-20
Assembly	17-4d	17-21
Front Spring Seat Removal and		
Replacement	17-5	17-25
Preliminary Procedure	17-5a	17-25
Removal	17-5b	17-25
Replacement	17-5c	17-27
Rear Spring Removal and Replacement	17-6	17-29
Preliminary Procedures	17-6a	17-29
Removal	17-6b	17-29
Replacement	17-6c	17-31
Rear Leaf Spring Assembly Repair	17-7	17-33
Preliminary Procedures	17-7a	17-33
Disassembly	17-7b	17-33
Cleaning, Inspection, and Repair	17-7c	17-35
Assembly	17-7d	17-36
Rear Spring Seat Removal and		
Replacement	17-8	17-38
Preliminary Procedures	17-8a	17-38
Removal	17-8b	17-38
Replacement	17-8c	17-41
Rear Spring Seat Repair	17-9	17-46
Preliminary Procedures	17-9a	17-46
Disassembly	17-9b	17-47
Assembly	17-9c	17-48
Rear Spring Seat With Bearings Removal		
and Replacement	17-10	17-49
Preliminary Procedures	17-10a	17-49
Removal	17-10b	17-49
Replacement	17-10c	17-52

TABLE OF CONTENTS-CONT

	Paragraph	Page
Section III. Shock Absorbers		17-57
Shock Absorber Removal and Replacement	17-11	17-57
Preliminary Procedure	17-11a	17-57
Removal	17-11b	17-57
Replacement	17-11c	17-59
Section IV. Torque Rods		17-61
Torque Rods Removal and Replacement	17-12	17-61
Preliminary Procedures	17-12a	17-61
Removal	17-12b	17-62
Replacement	17-12c	17-65

CHAPTER 13

BRAKE SYSTEM GROUP MAINTENANCE

Section I. SCOPE

13-1. EQUIPMENT ITEMS COVERED . This chapter gives equipment maintenance procedures for the handbrake assembly and related parts, service brake, hydraulic brake system, mechanical brake system, air brake system, compressed air system, and trailer brake connections for which there are authorized corrective maintenance tasks at the organizational maintenance level.

13-2. EQUIPMENT ITEMS NOT COVERED. All equipment items for which corrective maintenance is authorized at the organizational maintenance level are covered in this chapter.

Section II. HANDBRAKE ASSEMBLY AND RELAYED PARTS

13-3. HANDBRAKE BRAKE DRUM REMOVAL AND REPLACEMENT.

<p>TOOLS: Pliers 6-inch ruler Torque wrench, 150 pound-foot capacity Container Adapter, 1/2 inch to 3/4 inch 3-inch extension, 3/4-inch drive Hammer</p>	<p>3/4-inch wrench 1 7/16-inch wrench 1 5/16-inch wrench 1 1/2-inch socket Flat-tip screwdriver 6-inch adjustable wrench Brass punch</p>
--	--

SUPPLIES: Cotter pin

PERSONNEL: One

EQUIPMENT CONDITION: Truck parked, engine off, handbrake set, wheels chocked.

a. Preliminary Procedure. Remove propeller shaft. Refer to Part 2, para 10-3.

b. Removal.

FRAME 1

1. Using pliers, take cotter pin (1) out of handbrake drum near output shaft (2). Throw cotter pin away.
2. Using 1 1/2-inch wrench, unscrew and take off slotted nut (3) and flat washer (4).
3. Put handbrake (in cab) in brake off (down) position.

GO TO FRAME 2

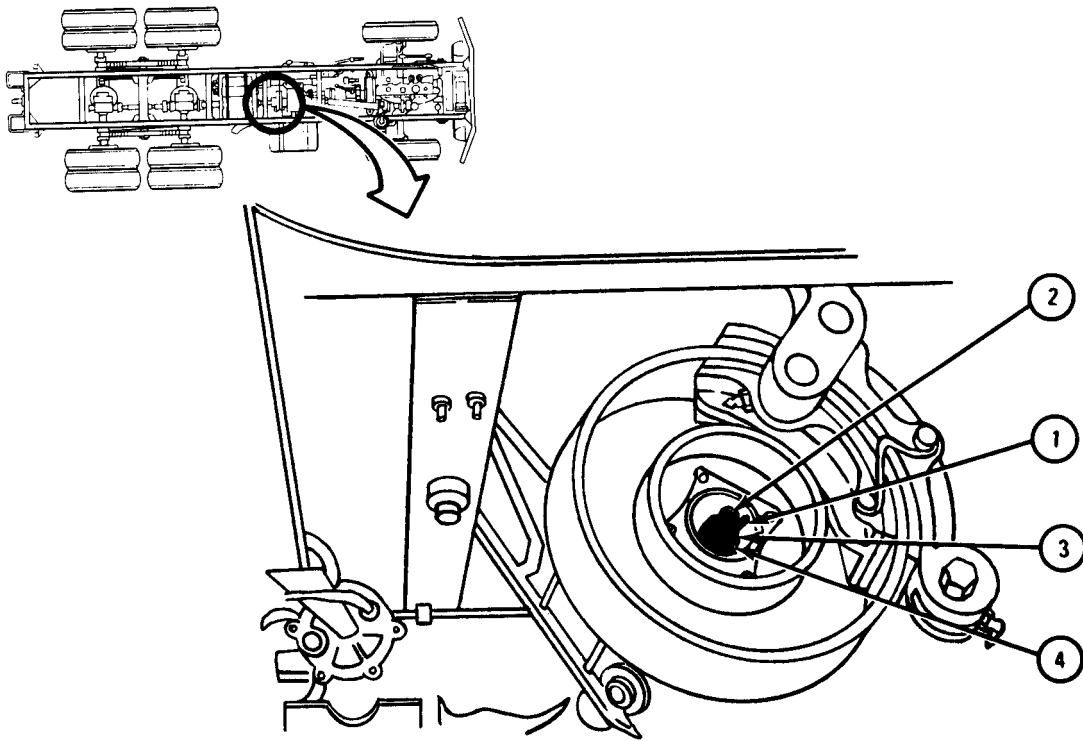

TA 046124

FRAME 2

NOTE

On trucks with exhaust pipe going to rear, exhaust pipe must be loosened and pushed away from brakeshoes. For trucks with engine LD 427, refer to Part 1, para 5-5. For trucks with engine LD 465, refer to Part 1, para 5-3. For all other trucks, refer to Part 1, para 5-4.

1. Using screwdriver, lift spring (1) off screw (2).
2. Using pliers, unhook spring (3) from lever (4).
3. Using adjustable wrench, hold cable (5). Using 3/4-inch wrench, unscrew and take off nut (6).
4. Pull cable (5) out of eye of lever (4).

GO TO FRAME 3

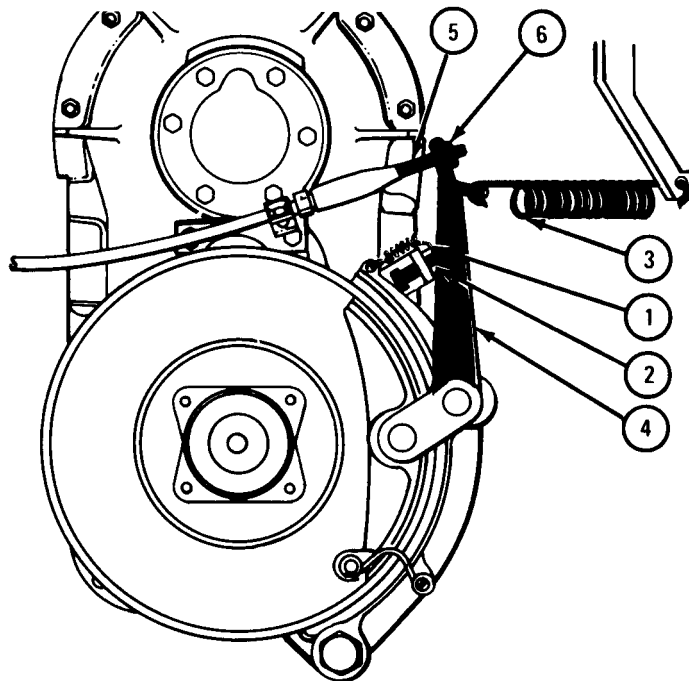

TA 046125

FRAME 3

1. Using 1 7/16-inch wrench, unscrew and take off jamnut (1).
2. Using 1 5/16-inch wrench, unscrew and take out anchor screw (2) and spacer (3).
3. Pull lever assembly (4) with brakeshoes (5) away from handbrake brake drum (6).

GO TO FRAME 4

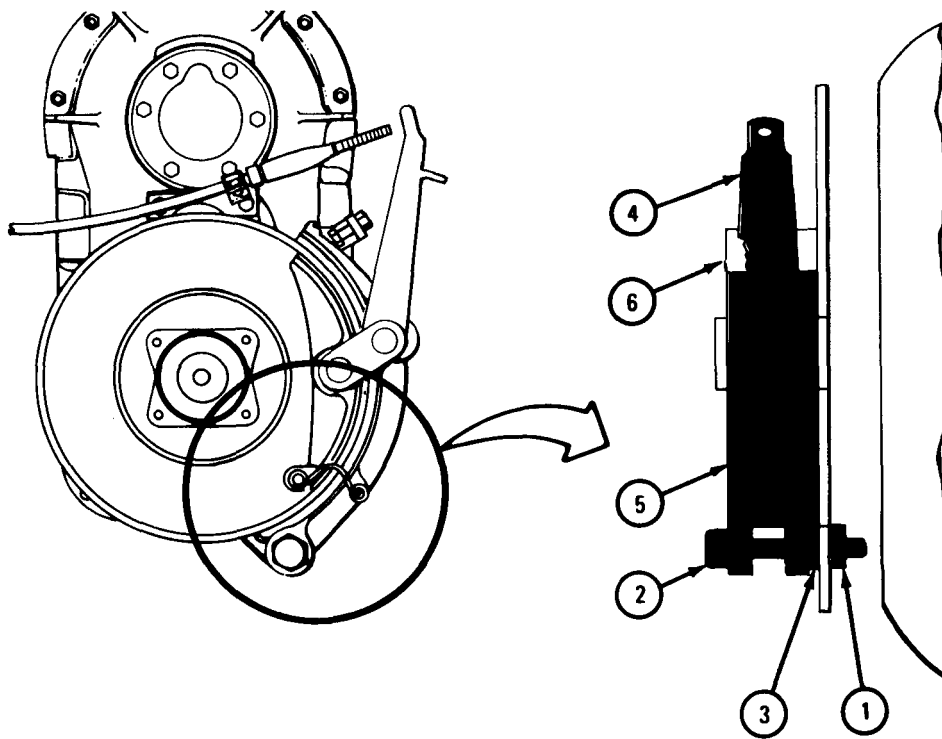

TA 046126

FRAME 4

1. Place container under handbrake brake drum (1) to catch oil.
2. Take handbrake brake drum (1) off output shaft (2).
3. Place handbrake brake drum (1) on workbench with open side down.
4. Using brass punch and hammer, tap out companion flange (3).
5. Take off dirt deflector (4) from inside of handbrake brake drum (1). Take out companion flange (3) and grease shield (5).

END OF TASK

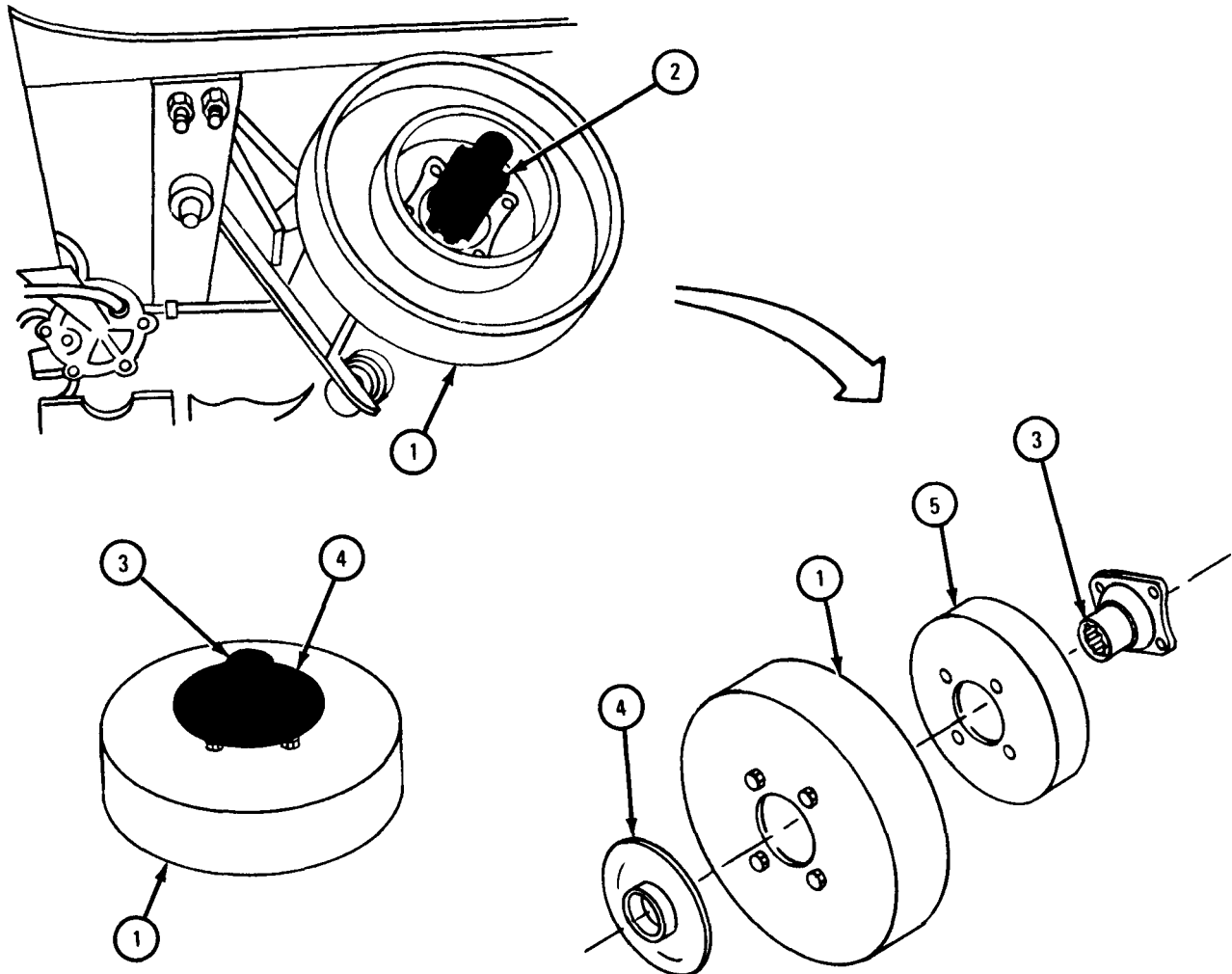

TA 046127

c. Replacement.

FRAME 1

1. Put grease shield (1) into handbrake brake drum (2) on four screws (3).
2. Put companion flange (4) through grease shield (1) and brake drum (2) on four screws (3).
3. Put dirt deflector (5) on companion flange (4).
4. Hold companion flange (4) in handbrake brake drum (2) and put assembly onto output shaft (6).
5. Put flat washer (7) on output shaft (6). Screw on and hand tighten nut (8) onto shaft.

GO TO FRAME 2

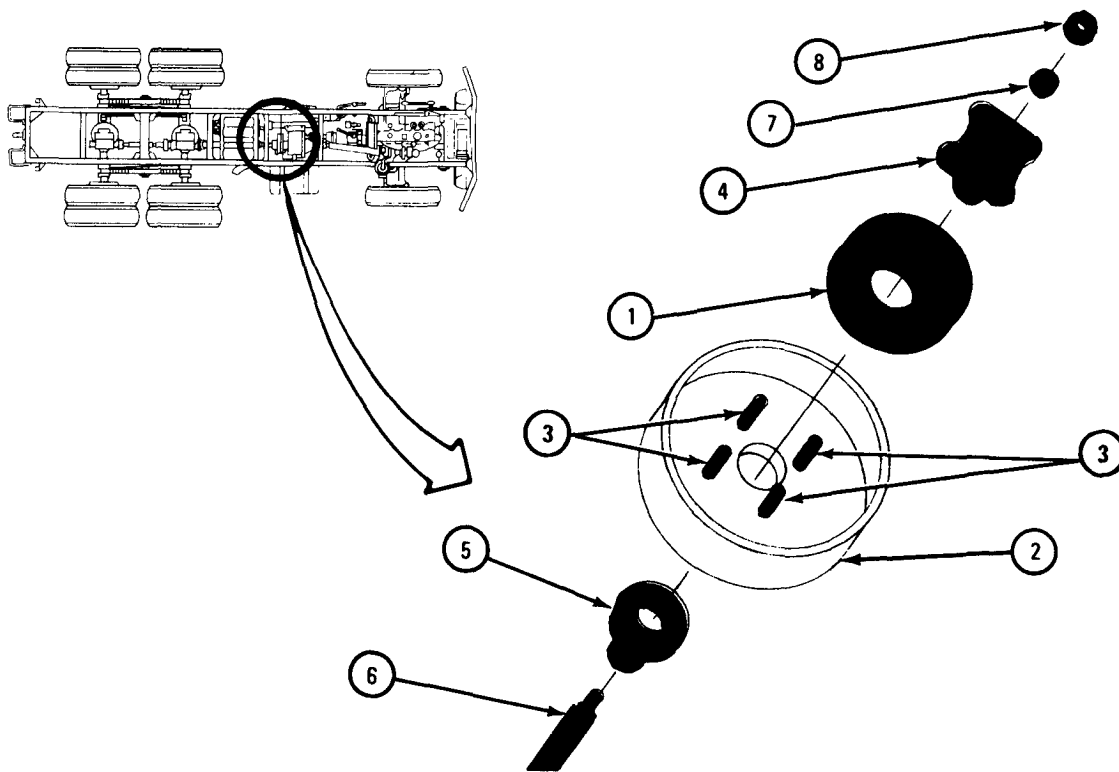

TA 046128

FRAME 2

1. Put lever assembly (1) with brakeshoes (2) onto handbrake brake drum (3).
2. Put anchor screw (4) through outer brakeshoe (2). Put on spacer washer (5) and screw anchor screw into bracket (6).
3. Using 6-inch ruler, check that brakeshoe (2) is flush with handbrake brake drum (3) within 1/16inch. If brakeshoe is not within limit given, add spacer washer(s) (5).
4. Screw jamnut (7) onto anchor screw (4).

NOTE

Do not tighten anchor screw (4) too tightly. Make sure brakeshoes (2) do not bind.

5. Using 1 15/16-inch wrench, screw in anchor screw (4).
6. Using 1 7/16-inch wrench, tighten jamnut (7).

GO TO FRAME 3

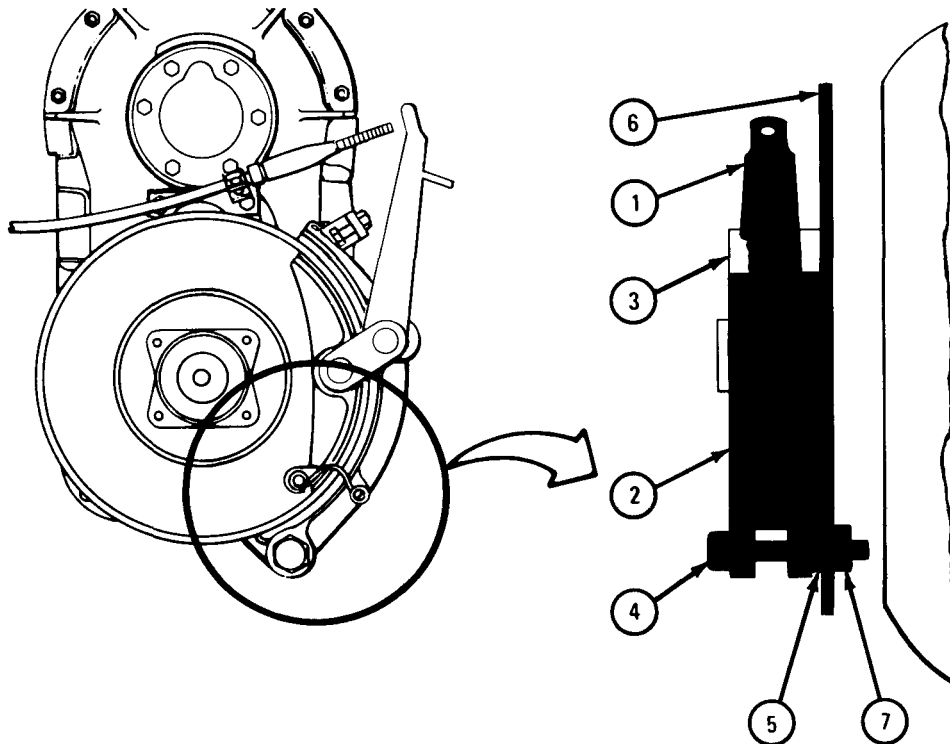

TA 083399

FRAME 3

1. Pass end of handbrake cable (1) through eye of lever assembly (2).
2. Screw nut (3) two turns onto end of handbrake cable (1).
3. Using adjustable wrench, hold cable (1). Using 3/4-inch wrench, screw on nut (3) until 1/4inch of handbrake cable comes through nut.
4. Hook spring (4) over adjusting screw (5).
5. Using pliers, hook spring (6) into hole in lever assembly (2).

NOTE

On trucks with exhaust pipe going to rear, exhaust pipe must be put back in place and tightened. For trucks with engine LD 427, refer to Part 1, para 5-5. For trucks with engine LD 465, refer to Part 1, para 5-3. For all other trucks, refer to Part 1, para 5-4.

GO TO FRAME 4

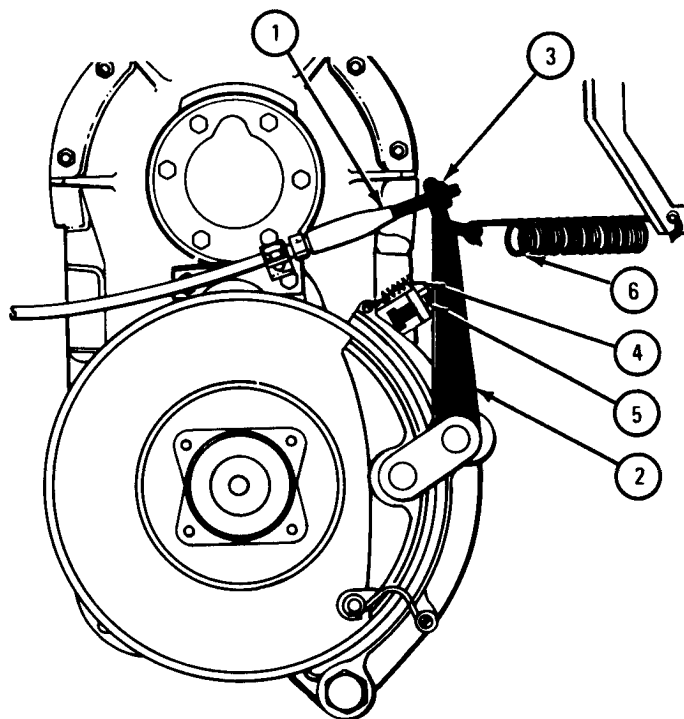

TA 046130

FRAME 4

1. Put handbrake (in cab) in brake on (up) position.

CAUTION

Torque reading must not be more than 100 pound-feet.

2. Using torque wrench with 1 1/2-inch socket, tighten slotted nut (1) to 90 pound-feet. Tighten nut until cotter pin hole in output shaft (2) lines up with slot in nut.
3. Put cotter pin (3) in hole in output shaft (2).
4. Using pliers, bend ends of cotter pin (3) around slotted nut (1).

NOTE

Follow-on Maintenance Action Required:

1. Adjust handbrake lever linkage. Refer to para 13-7.
2. Replace propeller shaft. Refer to para 10-3.

END OF TASK

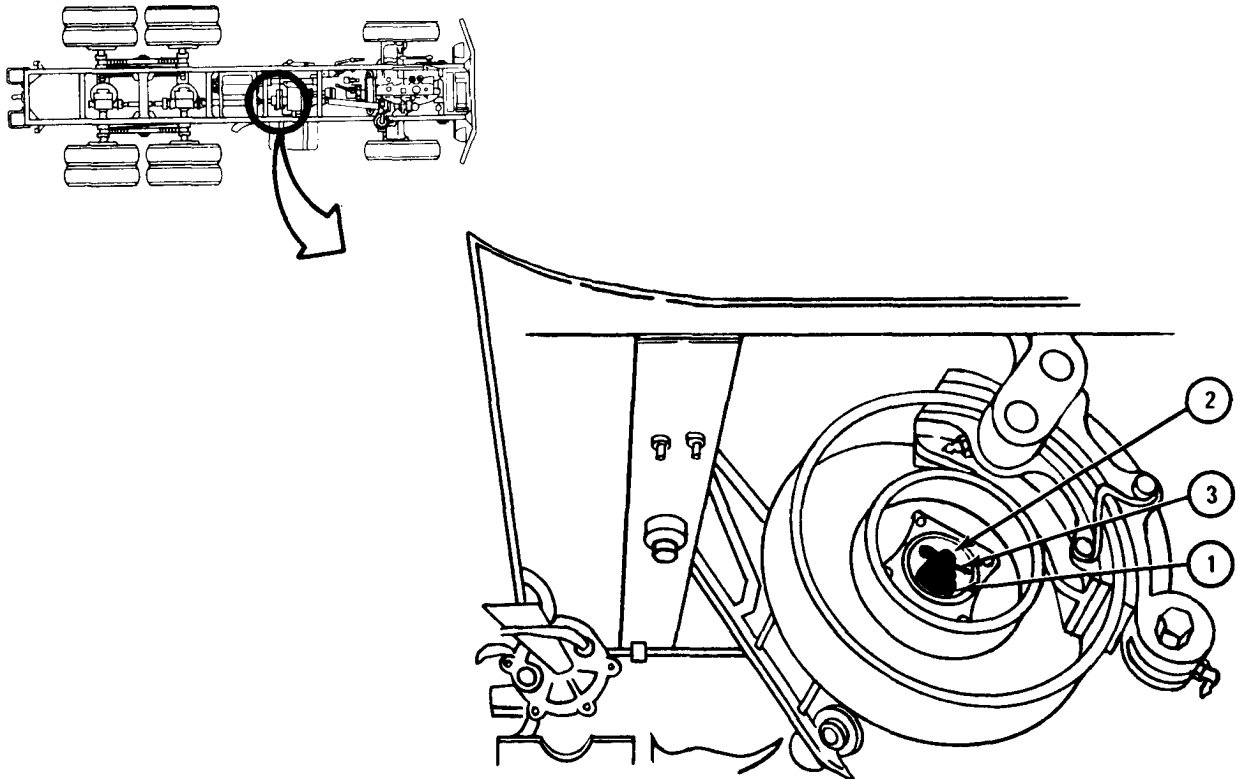

TA 046131

13-4. HANDBRAKE BRAKESHOES REMOVAL AND REPLACEMENT.

TOOLS:	5/8-inch wrench	3/4-inch wrench
	11/16-inch wrench	1 7/16-inch wrench
	5/16-inch wrench	1 5/16-inch wrench
	7/16-inch wrench	Flat-tip screwdriver
	6-inch ruler	Pliers

SUPPLIES: Spacers (as needed)

PERSONNEL: One

EQUIPMENT CONDITION: Truck parked, engine off, front wheels chocked, handbrake released.

a. Removal.

NOTE

On trucks with exhaust pipe going to rear of truck, pipe must be loosened and pushed away from brakeshoes. For trucks with engine LD-427, refer to Part 1, para 5-5. For trucks with engine LD-465, refer to Part 1, para 5-3. For all other trucks, refer to Part 1, para 5-4.

FRAME 1

1. Using 11/16-inch wrench, loosen jamnut (1). Using 5/8-inch wrench, back off adjusting screw (2). Lift spring (3) off screw (2) and unhook it.
2. Using 7/16-inch wrench, unscrew and take out grease fitting (4).
3. Using 5/16-inch wrench, hold nut (5). Using 3/4-inch wrench, unscrew and take off nut (6). Pull lever (7) off cable end (8).
4. Take off spring (9) from lever (7).

GO TO FRAME 2

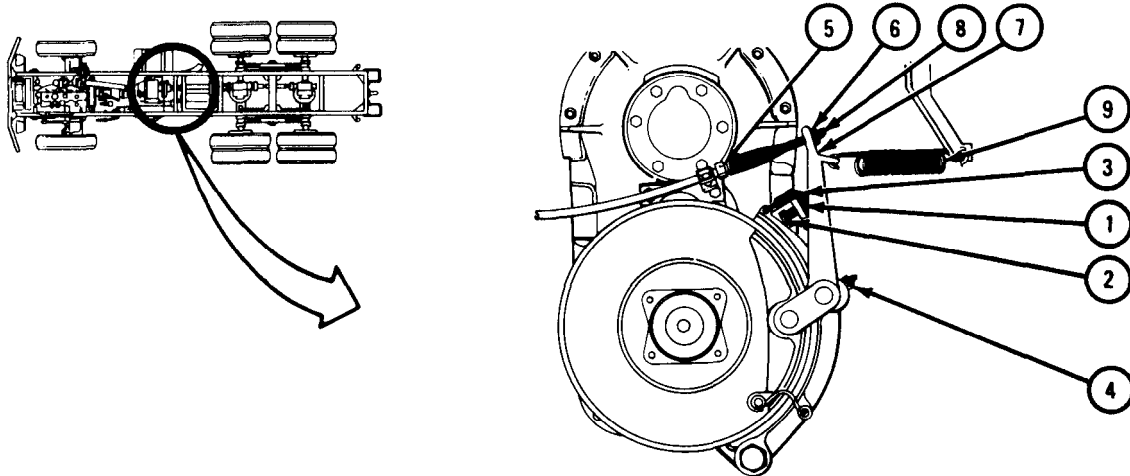

TA 085596

FRAME 2

1. Using 1 7/16-inch wrench, loosen jamnut (1). Hold jamnut, and using 1 15/16-inch wrench, unscrew and take out anchor screw (2), jamnut (1), and spacer (3).
2. Pull lever assembly (4), with brakeshoes (5), off of drum (6).

GO TO FRAME 3

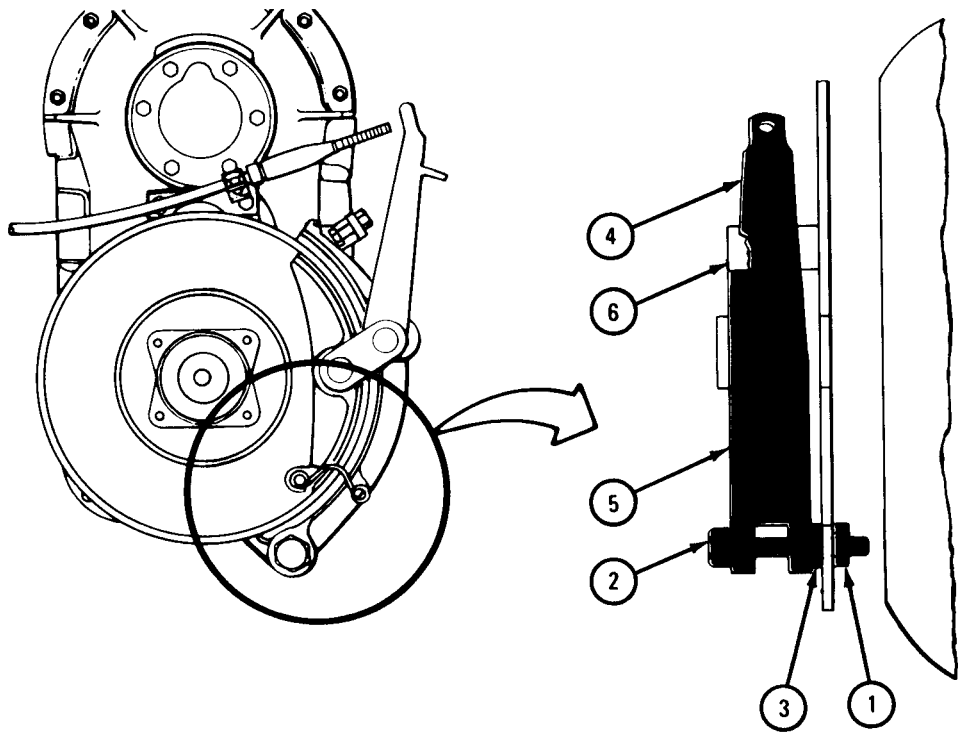

TA 085597

FRAME 3

1. Using screwdriver, takeoff retaining rings (1 and 2).
2. Takeoff stabilizer spring (3).
3. Take off washers (4 and 5).

GO TO FRAME 4

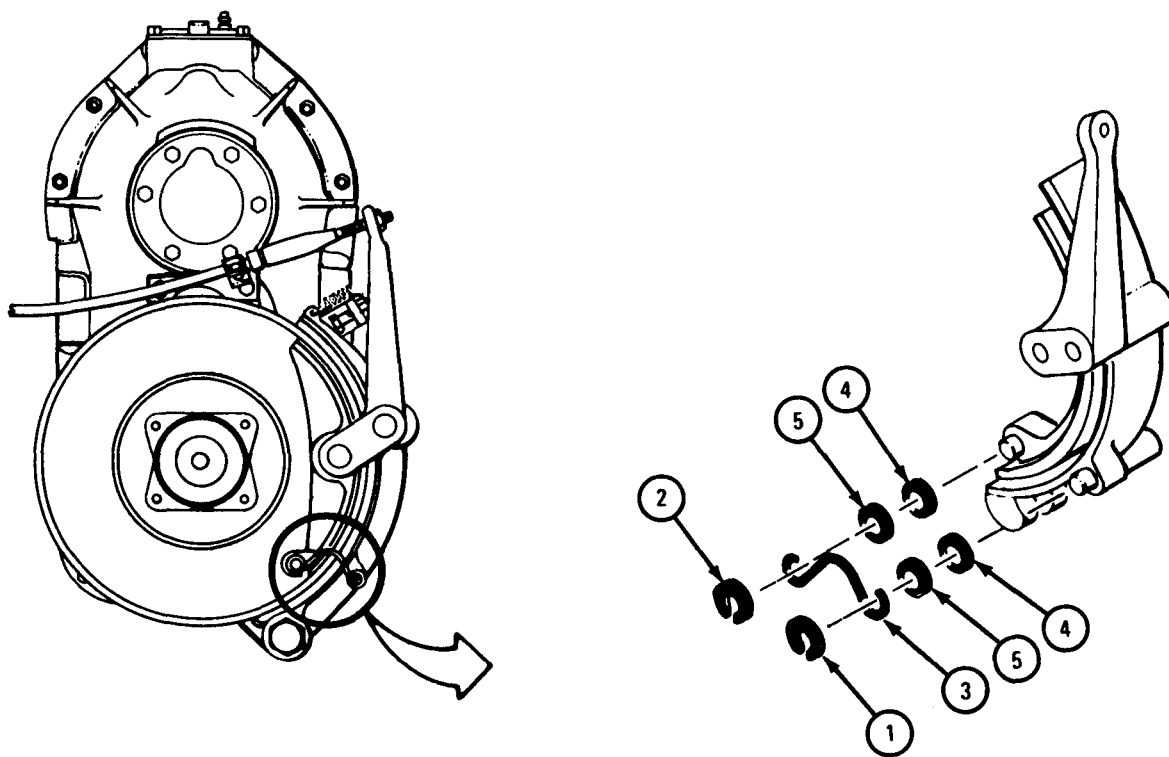

TA 085598

FRAME 4

1. Using screwdriver, take off retaining rings (1 and 2).
2. Lift outer brakeshoe (3) off lever pin (4).
3. Lift inner brakeshoe (5) off lever pin (6).

END OF TASK

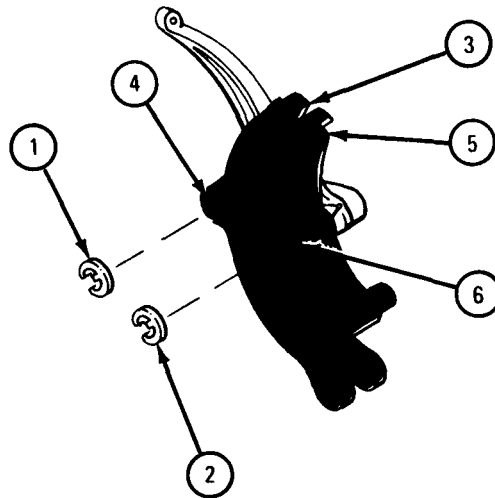

TA 085599

b. Replacement.

FRAME 1.

1. Slide outer brakeshoe (1) onto lever pin (2).
 2. Using pliers, put retaining ring (3) on lever pin (2).
 3. Slide inner brakeshoe (4) onto lever pin (5).
 4. Using pliers, put retaining ring (6) on lever pin (5).
- GO TO FRAME 2

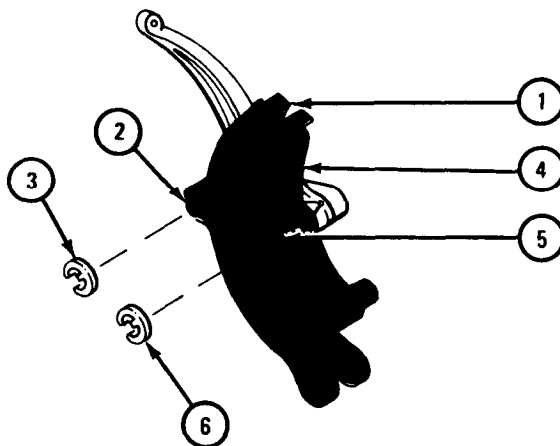

TA 085600

FRAME 2

1. Put brakeshoes (1) on brake drum (2). Put two washers (3 and 4) on post (5). Put spring (6) and retaining ring (7) on post (5).
2. Put two washers (3 and 4) on post (8). Put spring (6) and retaining ring (9) on post (8).

GO TO FRAME 3

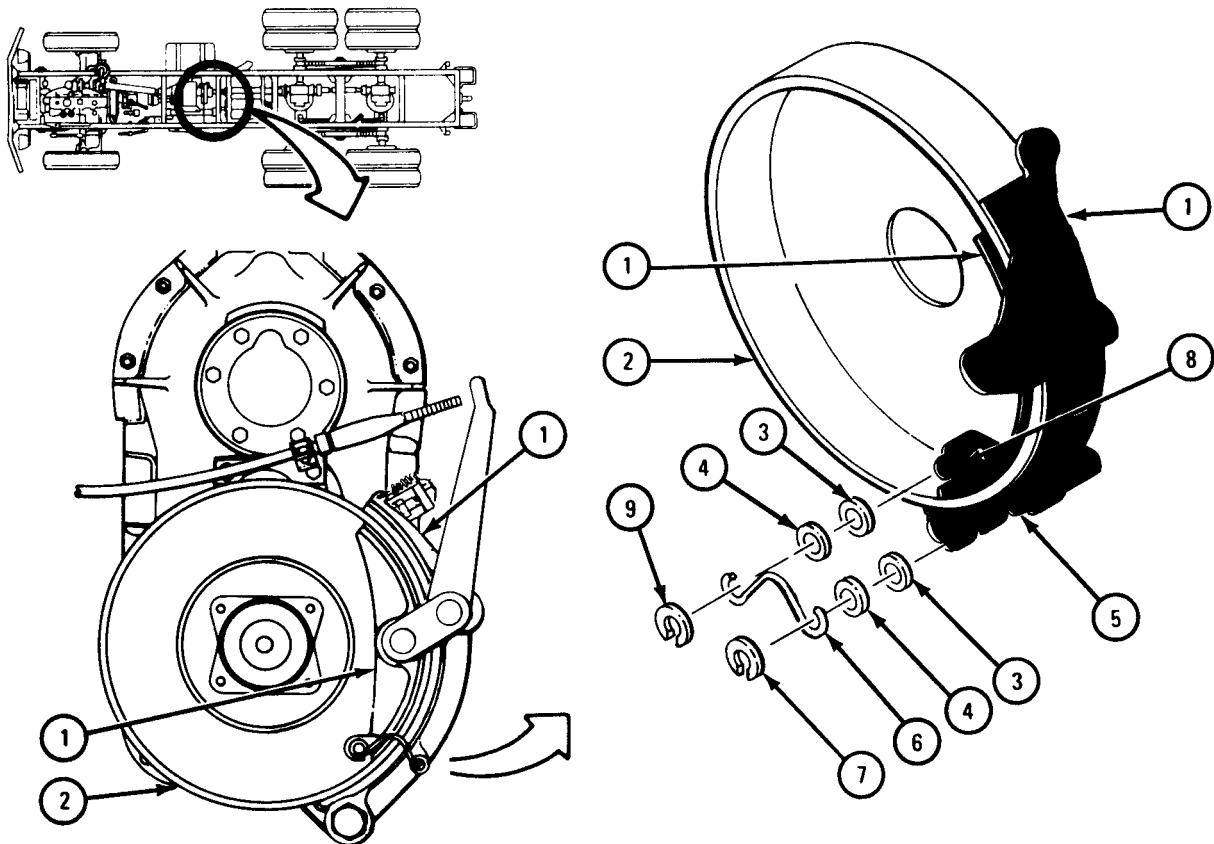

TA 101527

FRAME 3

1. Put anchor screw (1) through outer brakeshoe (2). Put spacer washer (3) on anchor screw and put screw through hole in bracket (4).
2. Using 6-inch ruler, check that brakeshoe (2) is flush with brake drum (5) or not more than 1/16 inch below brake drum. If brakeshoe is more than 1/16 inch below brake drum, add another spacer washer (3).
3. Screw jamnut (6) on anchor screw (1). Using 1 15/16-inch wrench, screw anchor screw into transfer case (7). Using 1 7/16-inch wrench, tighten jamnut (6) against transfer case.

GO TO FRAME 4

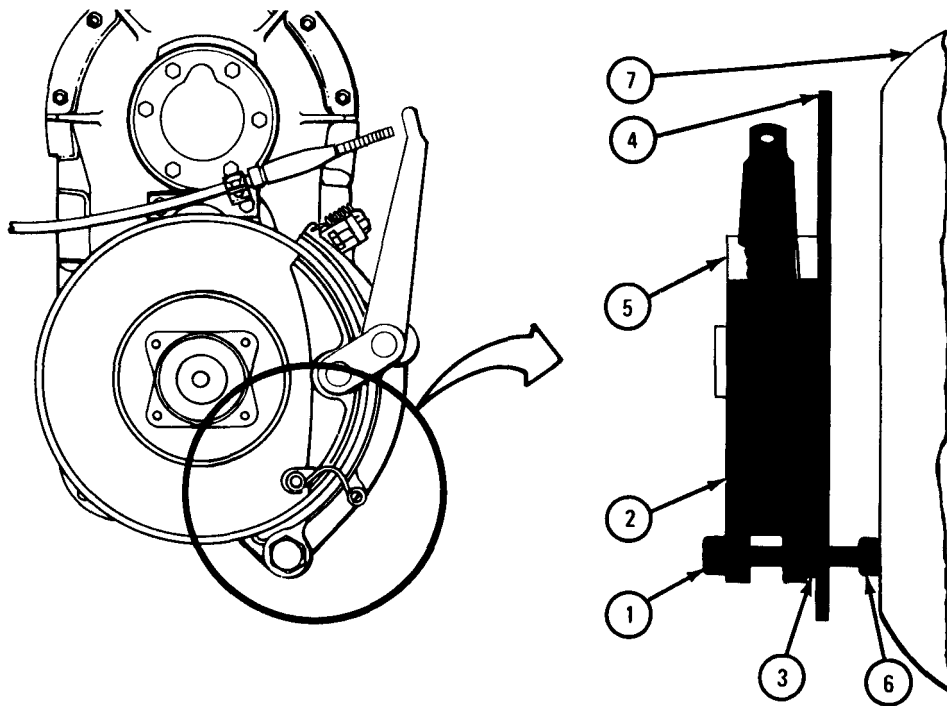

TA 046129

FRAME 4

1. Put end of handbrake cable (1) through lever assembly (2). Screw nut (3) on end of handbrake cable (1). Hook end of spring (4) on lever (2).
2. Using 5/16-inch wrench, hold nut (5). Using 3/4-inch wrench, tighten nut (3).
3. Hook end of spring (6) in hole (7). Hook other end of spring on adjusting screw (8).
4. Using 5/8-inch wrench, turn in adjusting screw (8) until spring (6) has tension. Using 1 1/16-inch wrench, tighten jamnut (9).
5. Using 7/16-inch wrench, screw in and tighten grease fitting (10).

NOTE

Follow-on Maintenance Action Required:

Adjust handbrake lever linkage. Refer to para 13-7.

END OF TASK

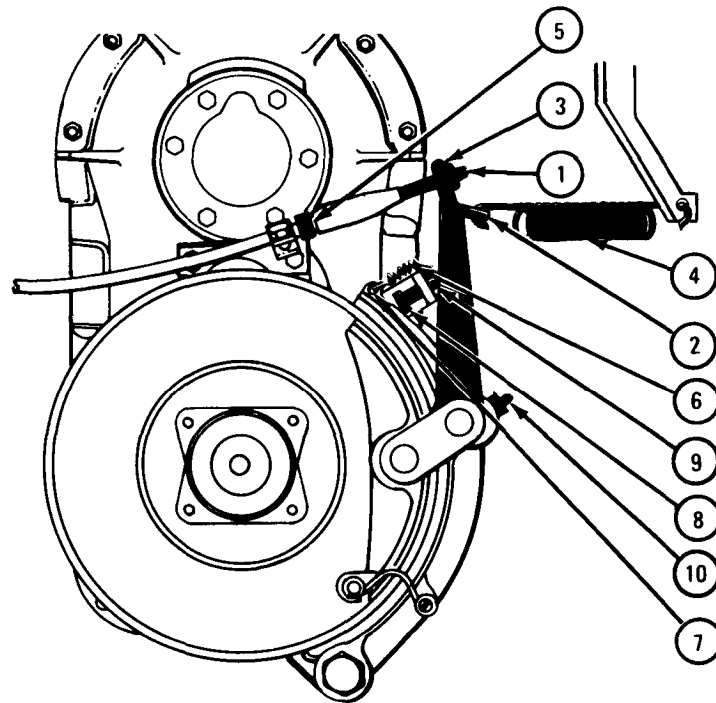

TA 101528

13-5. HANDBRAKE CABLE ASSEMBLY REMOVAL AND REPLACEMENT.

TOOLS: 9/16-inch wrench (2) 1/2-inch wrench
 7/16-inch wrench (2) 3/4-inch wrench
 Long nose pliers 5/16-inch wrench

SUPPLIES: None

PERSONNEL: One

EQUIPMENT CONDITION: Truck parked, engine off, handbrake set, wheels chocked.

a. Preliminary Procedure. On trucks where spare wheel is under chassis on driver's side, take off spare wheel. Refer to TM 9-2320-209-10.

NOTE

Trucks have two types of handbrake levers, over-center locking lever and ratchet and pawl lever. This task covers both types.

b. Removal of Overcenter Locking Handbrake Lever Cable.

FRAME 1

1. Using 5/16-inch wrench, hold shank (1). Using 3/4-inch wrench, unscrew and take off nut (2) from handbrake cable (3).
2. Using 1/2-inch wrench, unscrew and take out screw (4) and lockwasher (5).
3. Pull handbrake cable (3) free of handbrake lever (6) and clamp (7).

GO TO FRAME 2

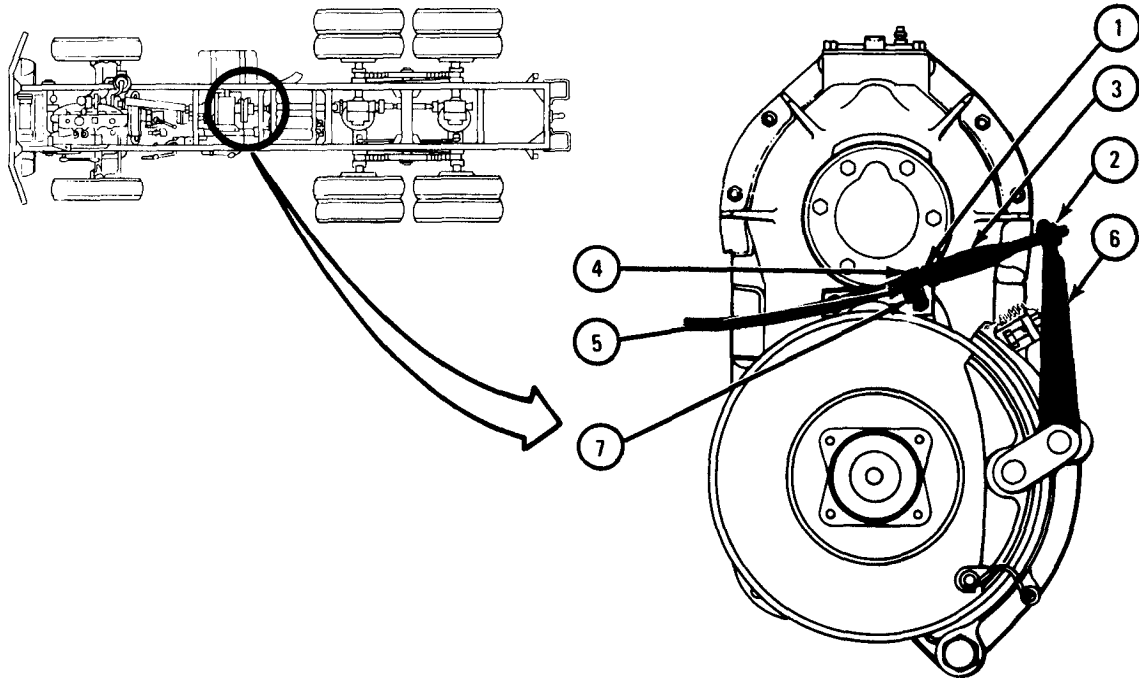

TA 046183

FRAME 2

1. Using pliers, pull cotter pin (1) out of clevis pin (2).
2. Take off washer (3).
3. Take out clevis pin (2).
4. Using 9/16-inch wrench, unscrew and take off four nuts (4).

GO TO FRAME 3

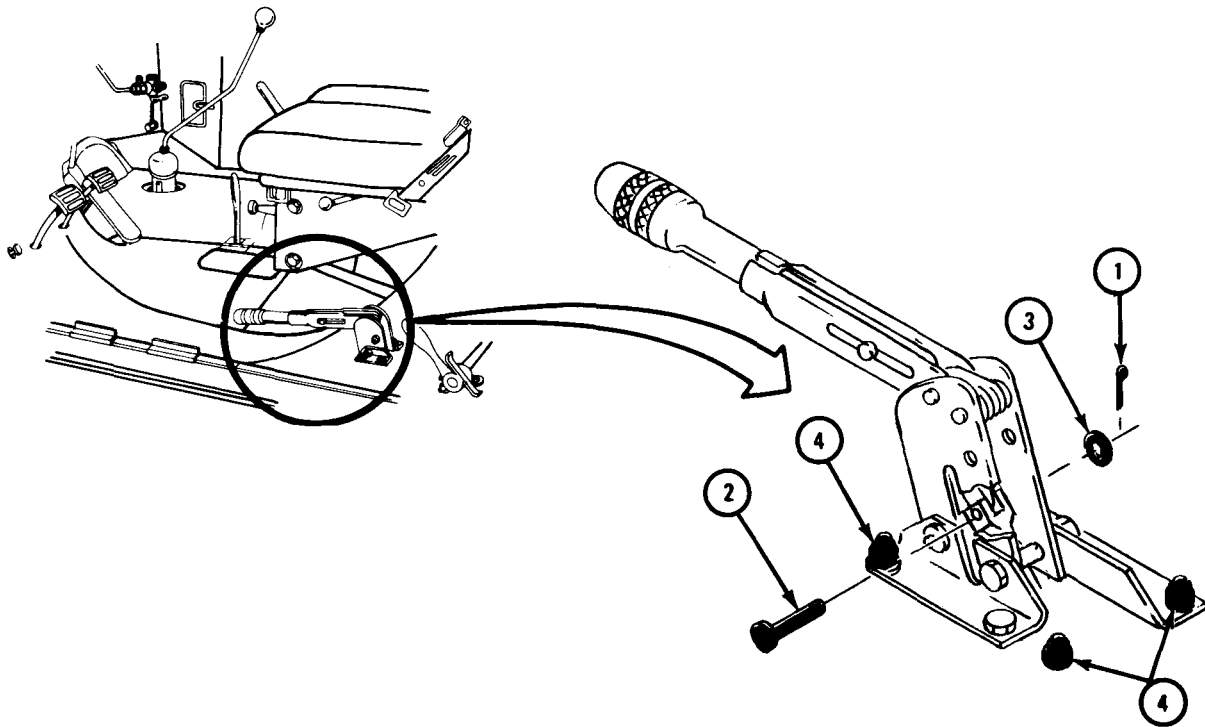

TA 046184

FRAME 3

1. Using 7/16-inch wrenches, unscrew and take off four nuts (1) and screws (2).
2. Take off two clamps (3) from wear plate (4). Take off handbrake cable (5).

GO TO FRAME 4

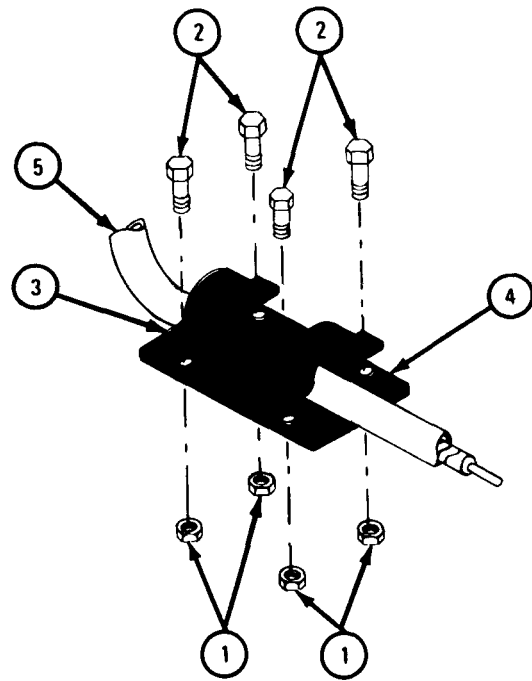
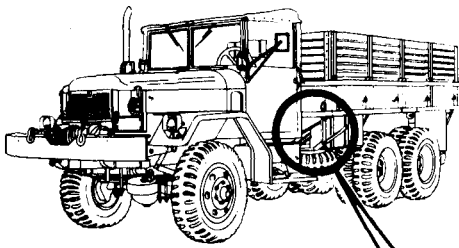

TA 080861

FRAME 4

NOTE

Open tool box door to make more room when working under cab floorboards.

1. Working under cab floorboard, pull cable (1) with bracket (2) down and to rear of truck.
2. Using 9/16-inch wrenches, unscrew and take off two nuts (3) and screws (4). Take off clamp (5) and spacer (6).

GO TO FRAME 5

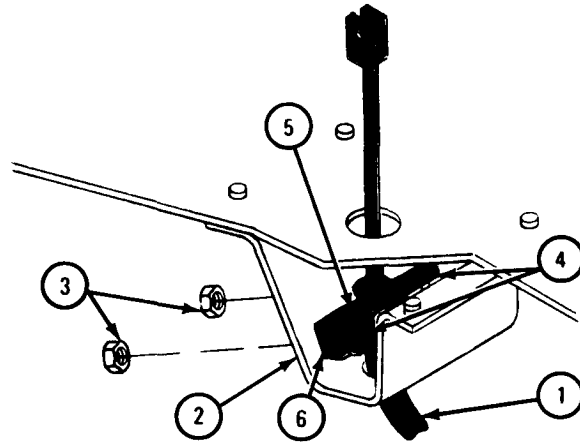

TA 046185

FRAME 5

1. Using 7/16-inch wrenches, unscrew and take off two screws (1) and nuts (2). Take off clamp parts (3 and 4).
2. Pull cable (5) out through truck frame (6).

END OF TASK

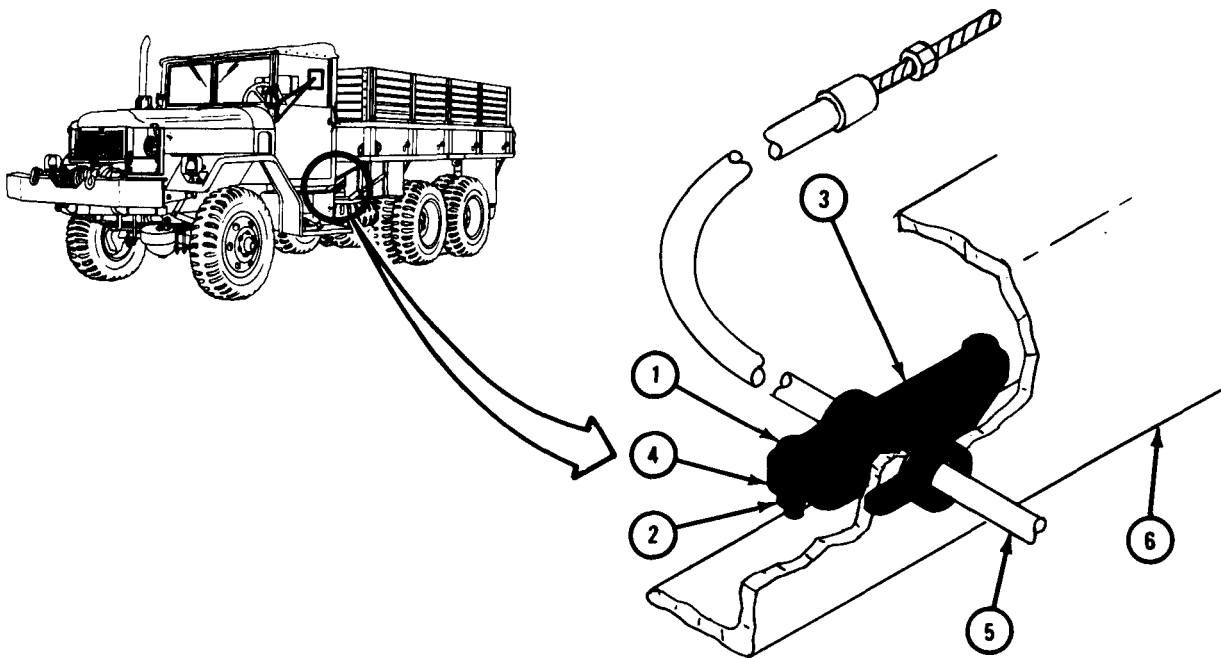

TA 046362

c. Removal of Ratchet and Pawl Handbrake Lever Cable.

FRAME 1

1. Using 7/16-inch wrench, hold nut (1). Using 3/4-inch wrench, unscrew and take off nut (2) from handbrake cable (3).
2. Using 1/2-inch wrench, unscrew and take out screw (4) and lockwasher (5).
3. Pull handbrake cable (3) free of handbrake lever (6) and clamp (7).

GO TO FRAME 2

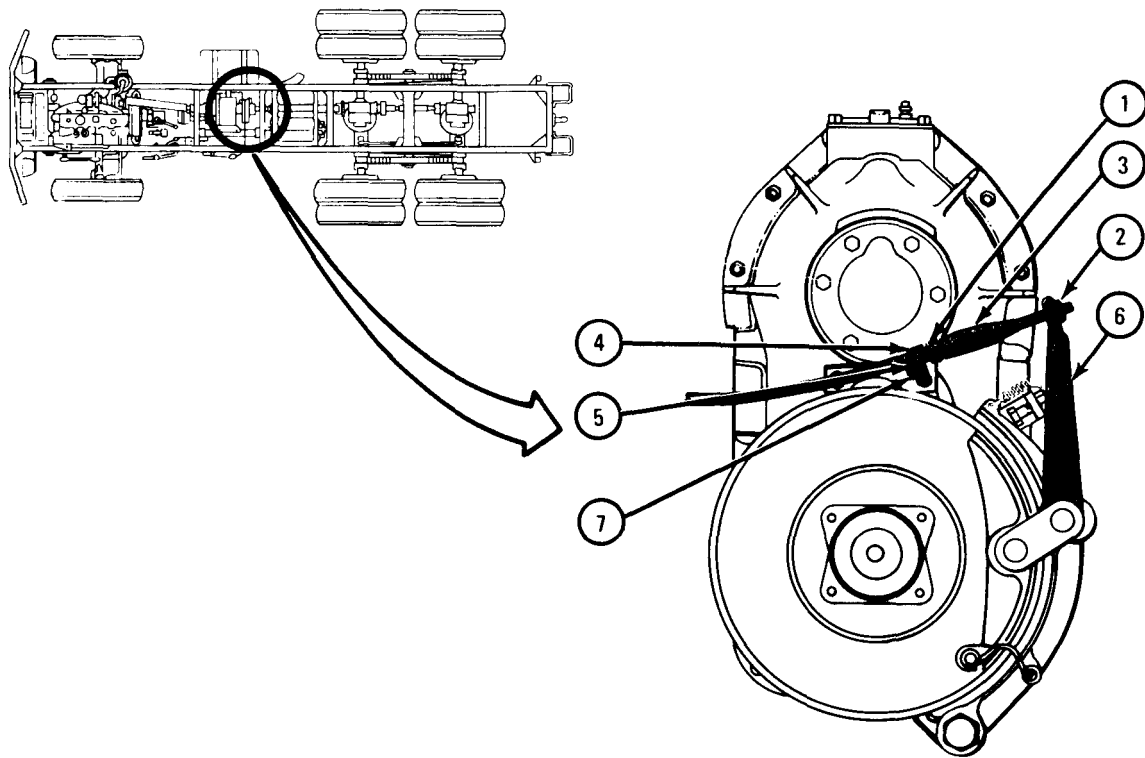

TA 046183

FRAME 2

1. Put handbrake lever (1) all the way down (brake off).
2. Using 1/2-inch and 7/16-inch wrenches, hold cable at nut (2) and unscrew and take off nut (3).

GO TO FRAME 3

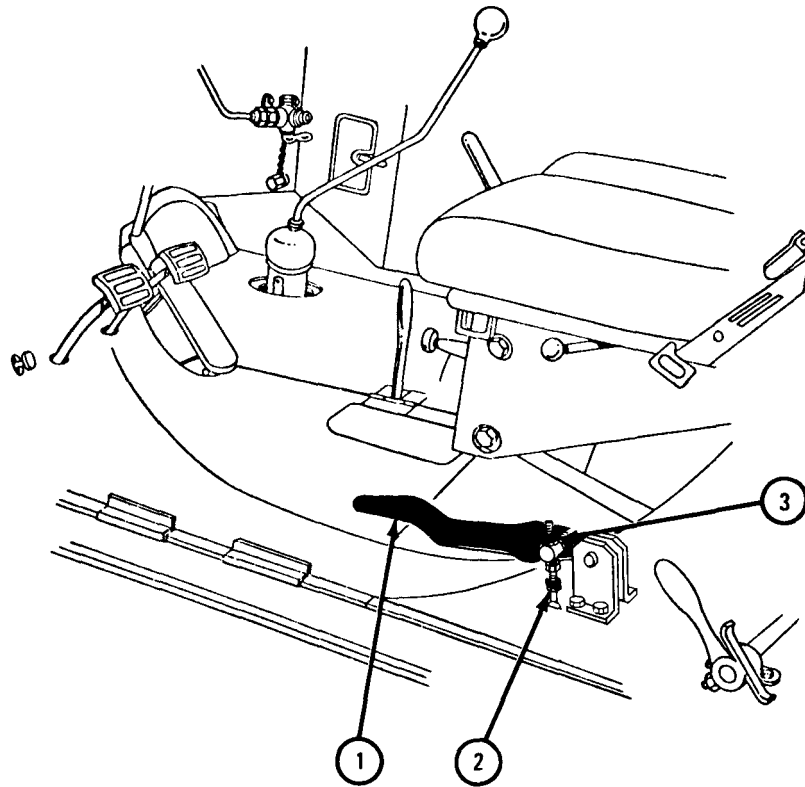

TA 080862

FRAME 3

1. Working under cab floorboard, using 7/16-inch wrench, unscrew and take off two nuts (1). Take out U-bolt (2).
2. Pull cable (3) down and to rear of truck.

GO TO FRAME 4

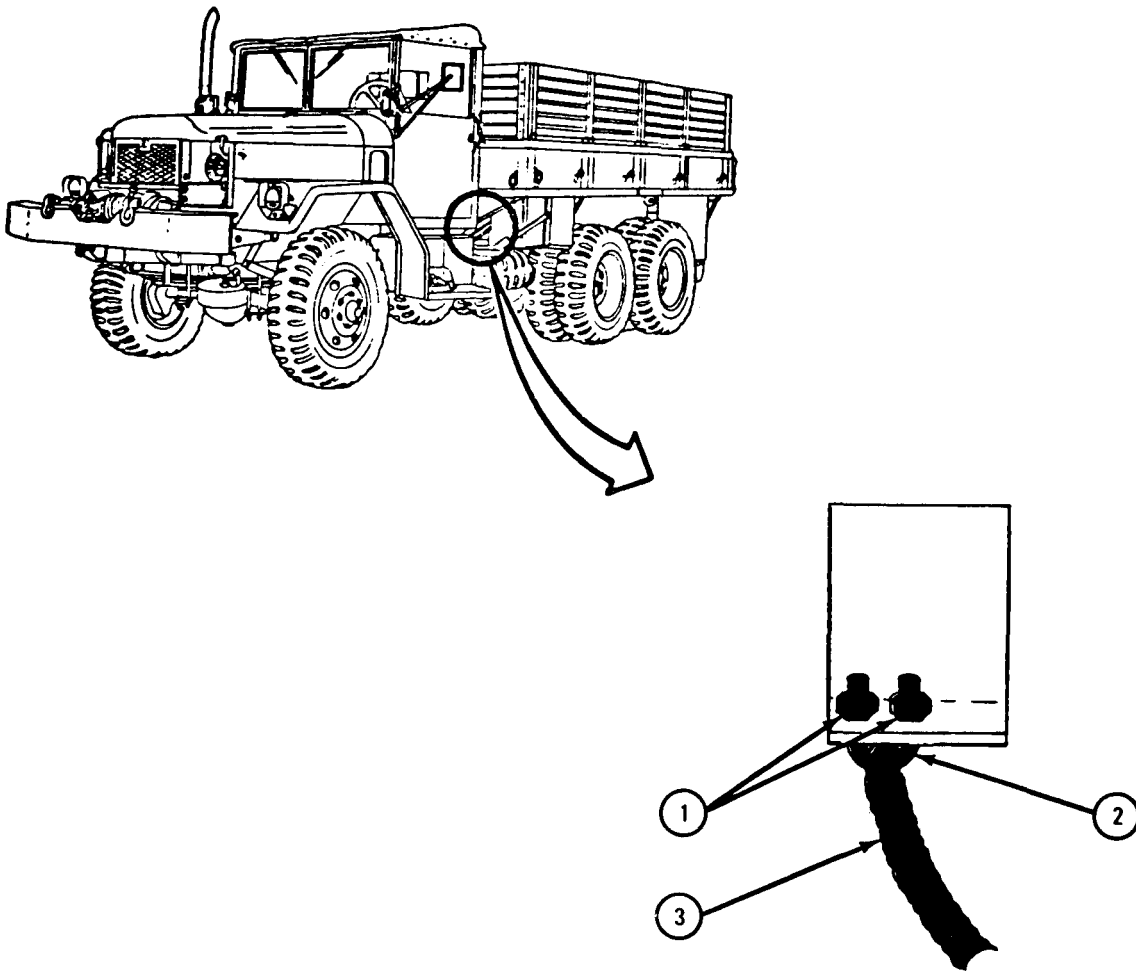

TA 080863

FRAME 4

1. Using 7/16-inch wrenches, unscrew and take off two screws (1) and nuts (2). Take off clamp parts (3 and 4).
2. Pull cable (5) out through truck frame (6).

END OF TASK

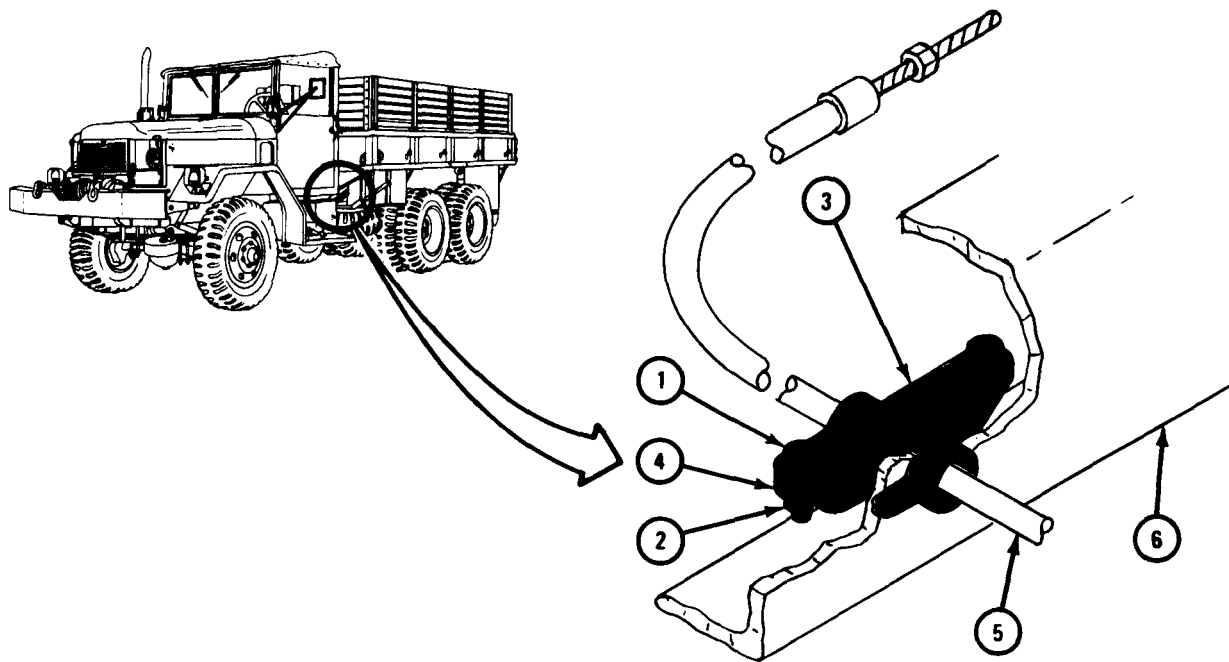

TA 046362

d. Replacement of Overcenter Locking Handbrake Lever Cable.

FRAME 1

CAUTION

Be careful when putting in handbrake cable (1) so that there are no sharp bends or kinks.

1. Find end of handbrake cable (1) that has yoke (2) and groove (3) on it. Put that end of handbrake cable up through hole in bottom of bracket (4).
2. Put spacer (5) between groove (3) on cable (1) and bracket (4). Put clamp (6) over groove. Line up screw holes in spacer, clamp, and bracket.
3. Put two screws (7) through clamp (6), spacer (5), and bracket (4). Using 9/16-inch wrenches, screw on and tighten two nuts (8).
4. Put bracket (4) under cab of truck from the rear and put four studs (9) through four holes in floorboard under handbrake lever.

GO TO FRAME 2

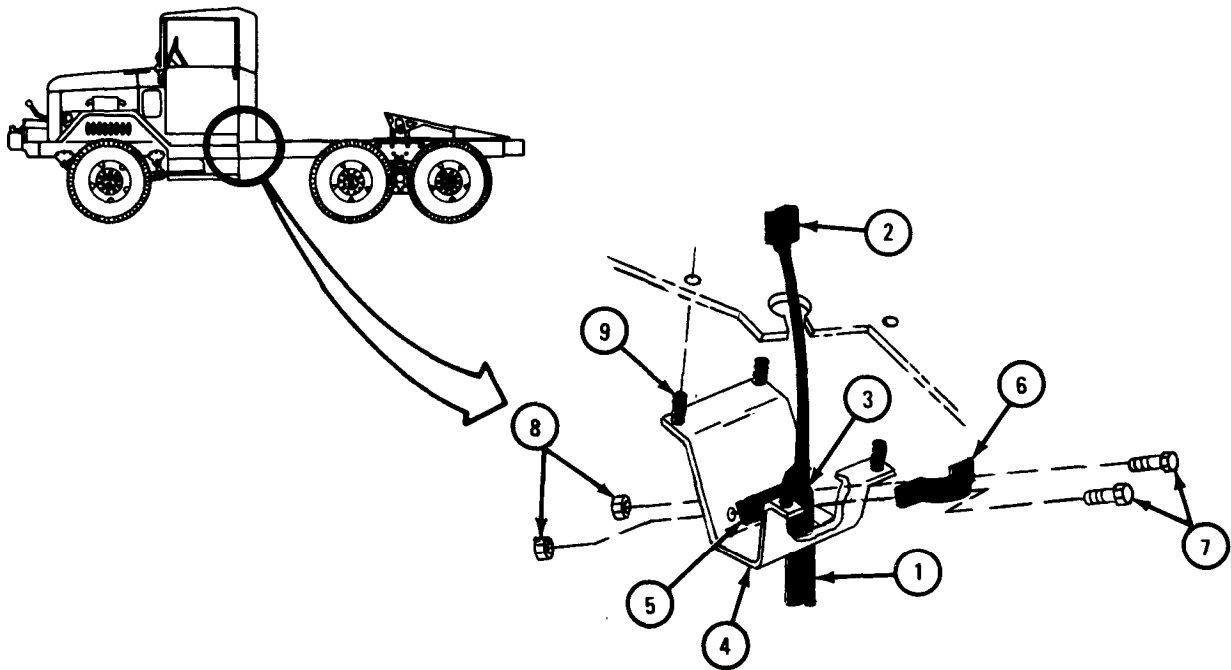

TA 046186

FRAME 2

1. Using 9/16-inch wrench, screw on and tighten four nuts (1) on studs (2). Using long nose pliers, put yoke (3) on lever (4), lining up holes. Put clevis pin (5) through yoke and lever.
2. Put washer (6) on clevis pin (5). Put cotter pin (7) through hole in clevis pin. Using pliers, bend open ends of cotter pin.

GO TO FRAME 3

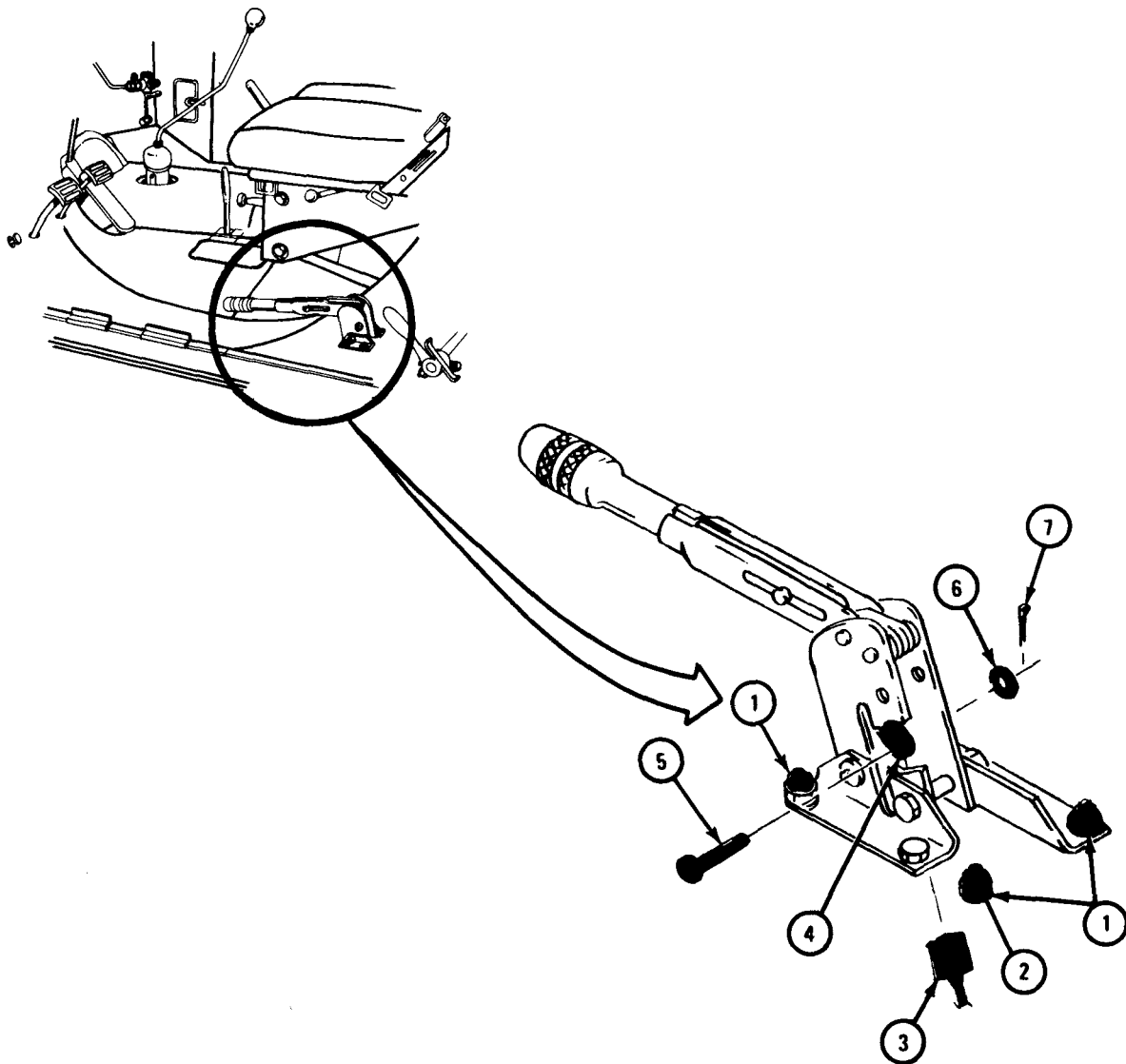

TA 046187

FRAME 3

1. Put loose end of handbrake cable (1) through hole in frame (2).
2. Put wearplate (3) under handbrake cable (1) so middle of wearplate is on corner of toolbox (4). Put two clamps (5) onto wearplate, lining up screw holes.
3. Put two screws (6) through each clamp (5) and wearplate (3). Using 7/16-inch wrench, screw on and tighten four nuts (7).

GO TO FRAME 4

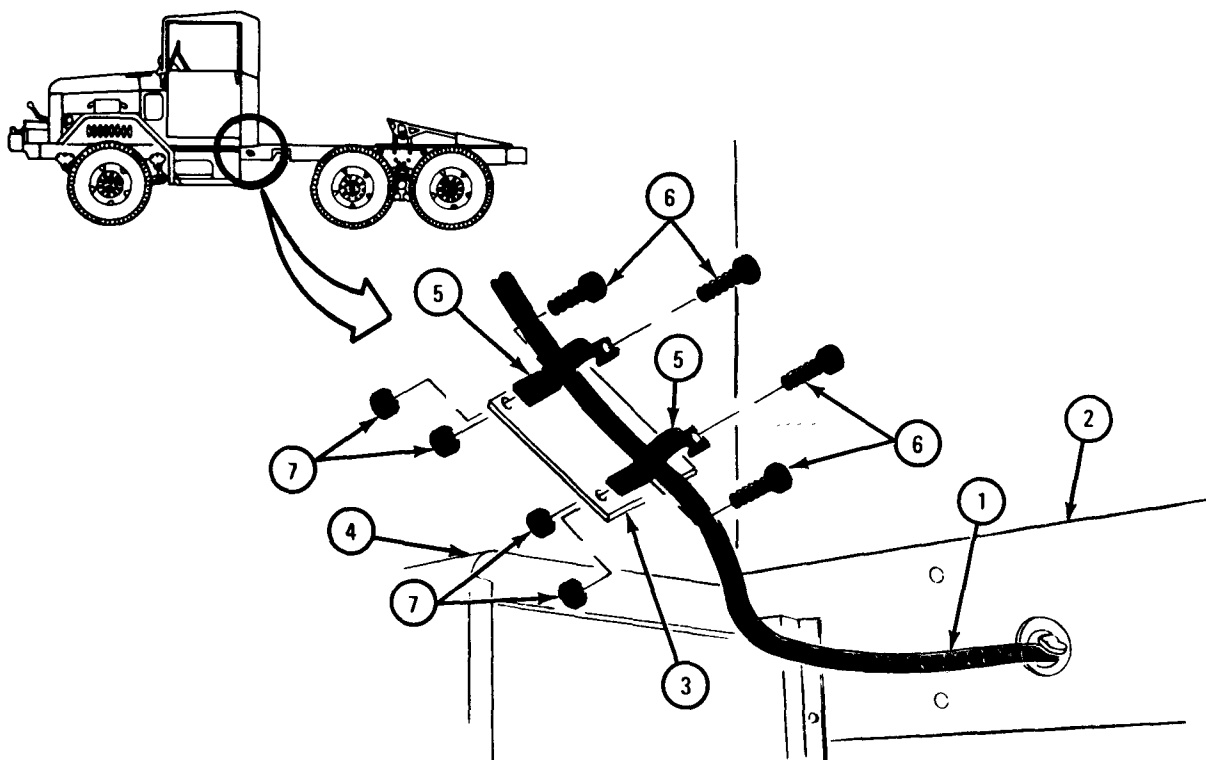

FRAME 4

1. Put handbrake cable (1) under clamp (2). Put lockwasher (3) on screw (4) and using 1/2-inch wrench, screw in and tighten screw.
2. Put end of handbrake cable (1) through hole in handbrake lever (5). Using 3/4-inch wrench, screw on nut (6).

GO TO FRAME 5

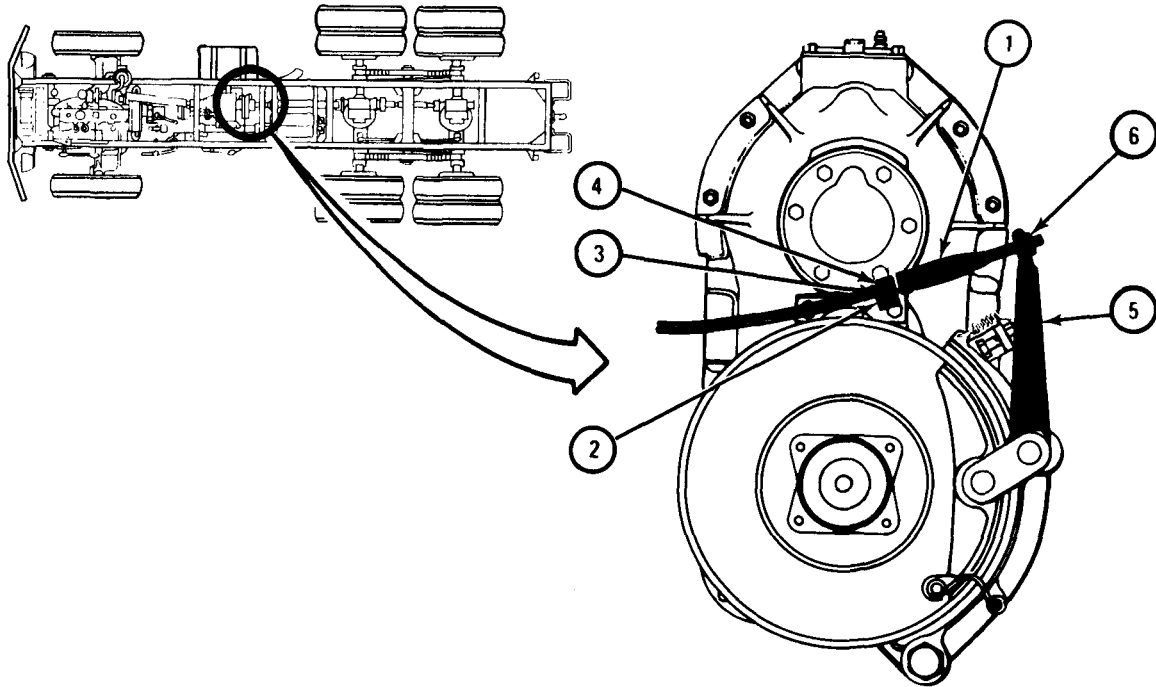

TA 046364

FRAME 5

1. From inside of truck frame (1), put piece of clamp part (2) through hole with handbrake cable (3). Slide clamp part onto truck frame.
2. Put other clamp part (4) onto handbrake cable (3), lining up screw holes in clamp parts (2 and 4). Handbrake cable must be between clamp parts.
3. Put two screws (5) through clamp parts (2 and 4). Using 7/16-inch wrenches, screw on and tighten nut (6).

NOTE

Follow-on Maintenance Action Required:

1. Adjust handbrake lever linkage. Refer to para 13-7.
2. Put spare wheel back on truck. Refer to TM 9-2320-209-10.

END OF TASK

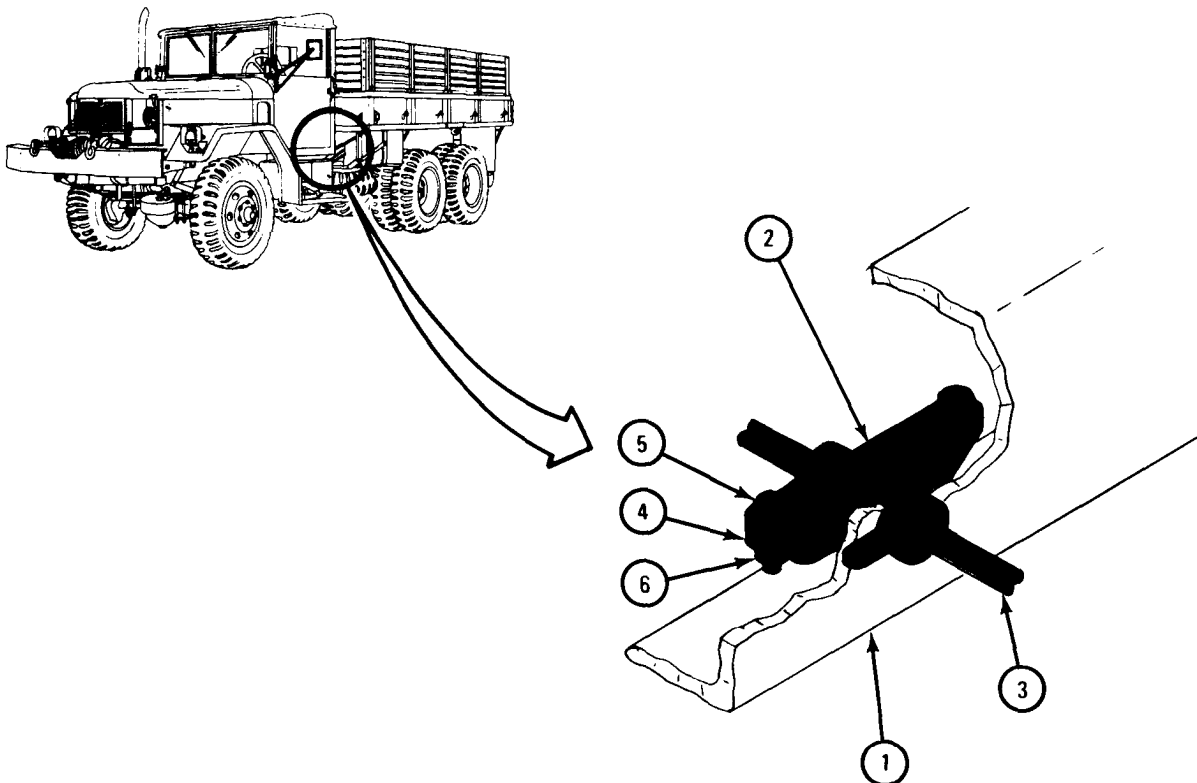

TA 046365

e. Replacement of Ratchet and Pawl Handbrake Lever Cable.

FRAME 1

CAUTION

Be careful when putting in handbrake cable (1) so that there are no sharp bends or kinks.

1. Working under cab floorboard, put cable (1) up through hole in floorboard under handbrake lever.
2. Put U-bolt (2) in place on bracket (3) and hold it tight against cable (1) at groove.
3. Using 7/16-inch wrench, screw on and tighten two nuts (4).

GO TO FRAME 2

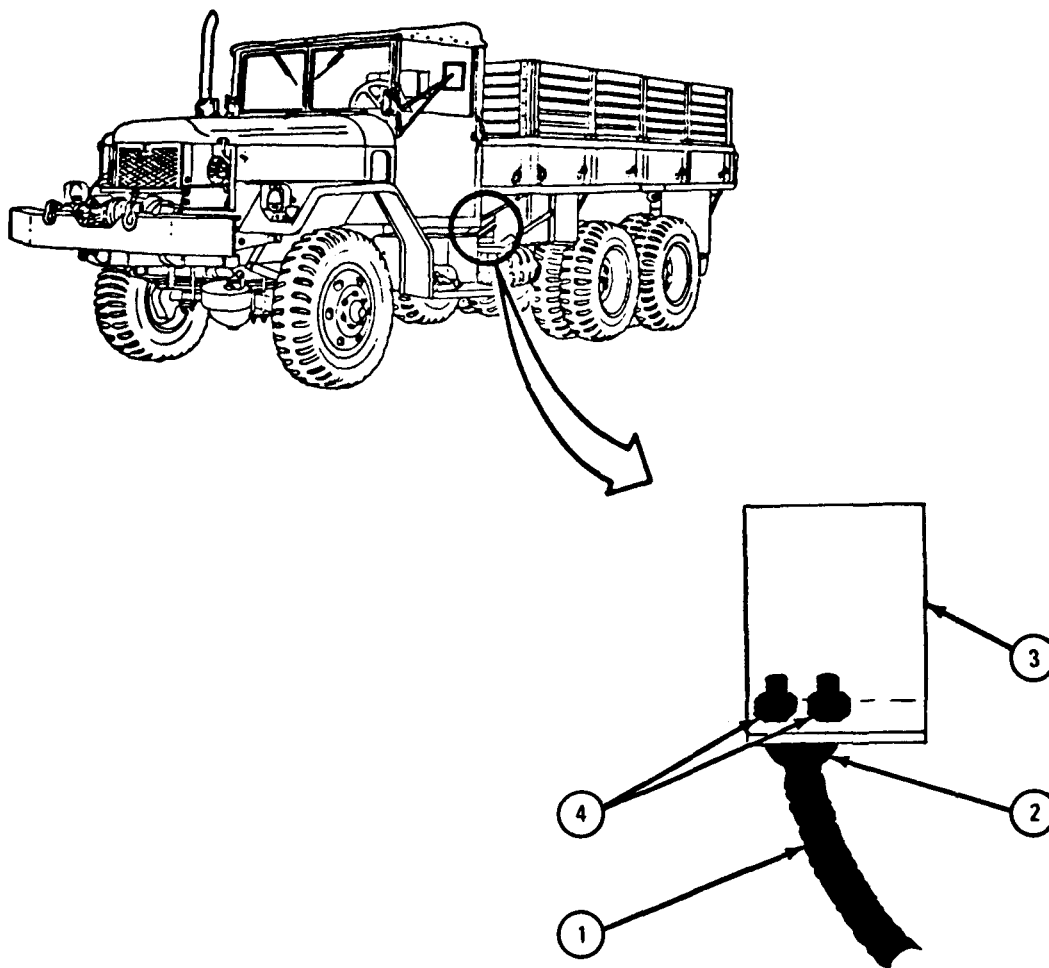

TA 080864

FRAME 2

1. Slide end of cable (1) through pin (2).
2. Put handbrake lever (3) all the way down (brake off).
3. Using 1/2-inch and 7/16-inch wrenches, hold nut (4) and screw nut (5) onto end of cable (2) until just a few threads show at end of cable.
4. Using 1/2-inch and 7/16-inch wrenches, hold nut (4) and screw nut (6) up until it is right against pin (2).

GO TO FRAME 3

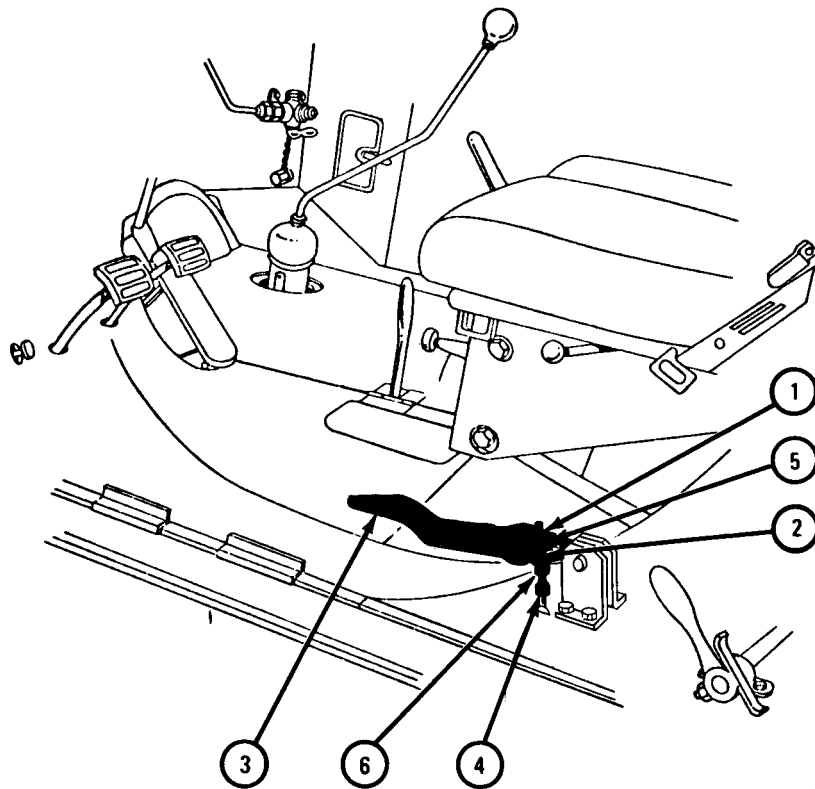

TA 080865

FRAME 3

1. Put loose end of handbrake cable (1) through hole in frame (2).
- GO TO FRAME 4

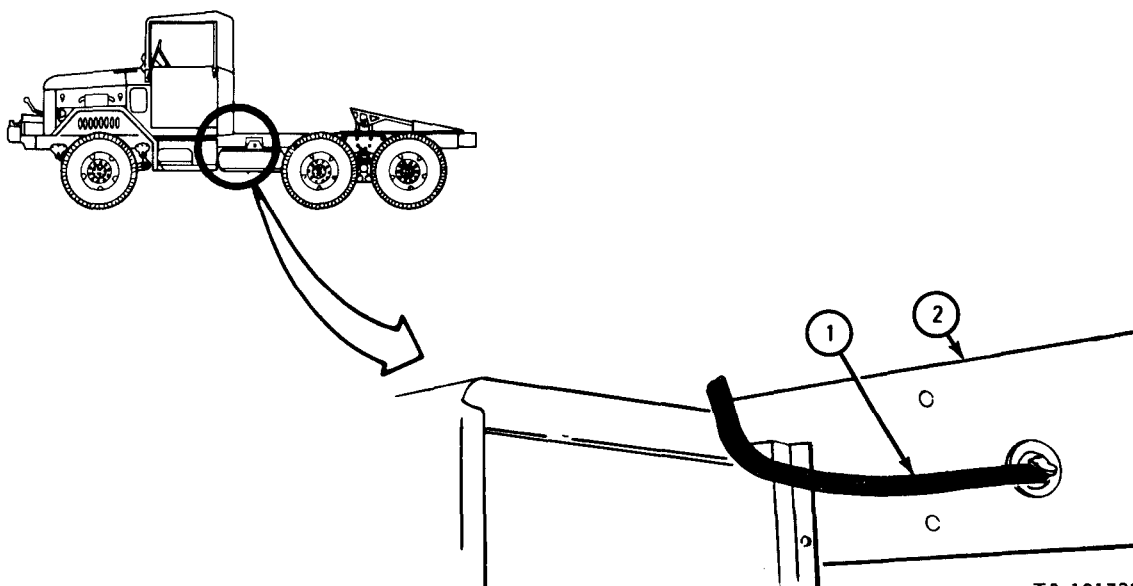

TA 101738

FRAME 4

1. Put handbrake cable (1) under clamp (2). Put lockwashers (3) on screw (4) and using 1/2-inch wrench, screw in and tighten screw.
2. Put end of handbrake cable (1) through hole in handbrake lever (5). Using 3/4-inch wrench, screw on nut (6).

GO TO FRAME 5

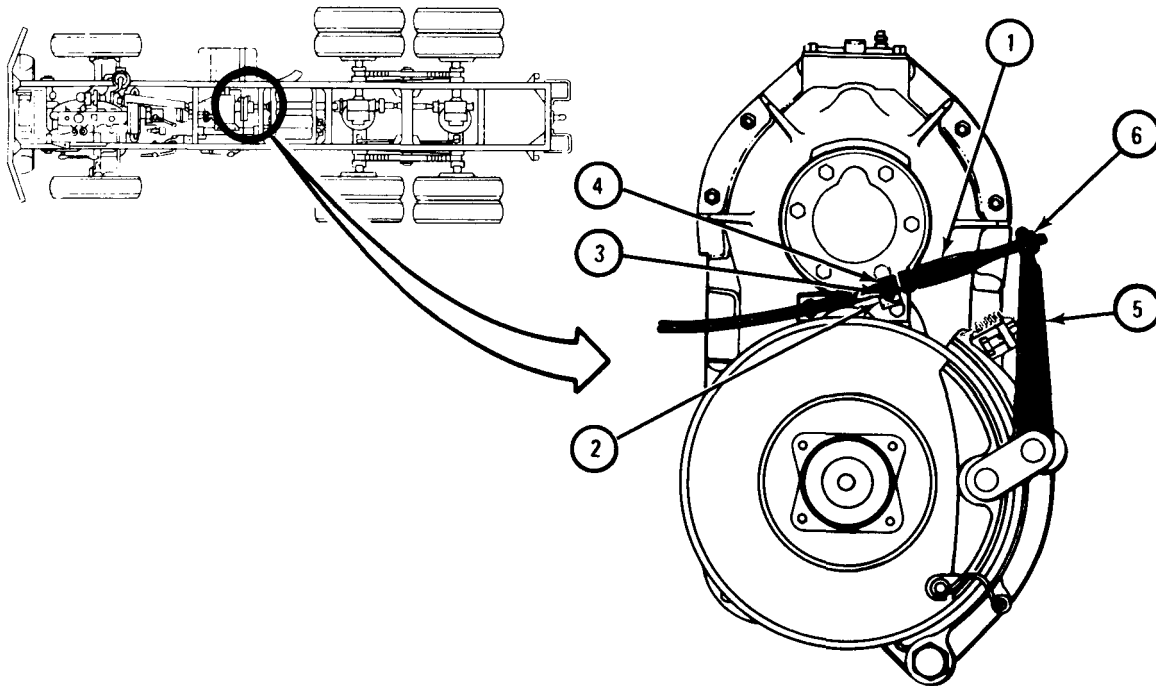

TA 046364

FRAME 5

1. From inside of truck frame (1), put piece of clamp part (2) through hole with handbrake cable (3). Slide clamp part onto truck frame.
2. Put other clamp part (4) onto handbrake cable (3), lining up screw holes in clamp parts (2 and 4). Handbrake cable must be between clamp parts.
3. Put two screws (5) through clamp parts (2 and 4). Using 7/16-inch wrenches, screw on and tighten nut (6).

NOTE

Follow-on Maintenance Action Required:

1. Adjust handbrake lever linkage. Refer to para 13-7.
2. Put spare wheel back on truck. Refer to TM 9-2320-209-10.

END OF TASK

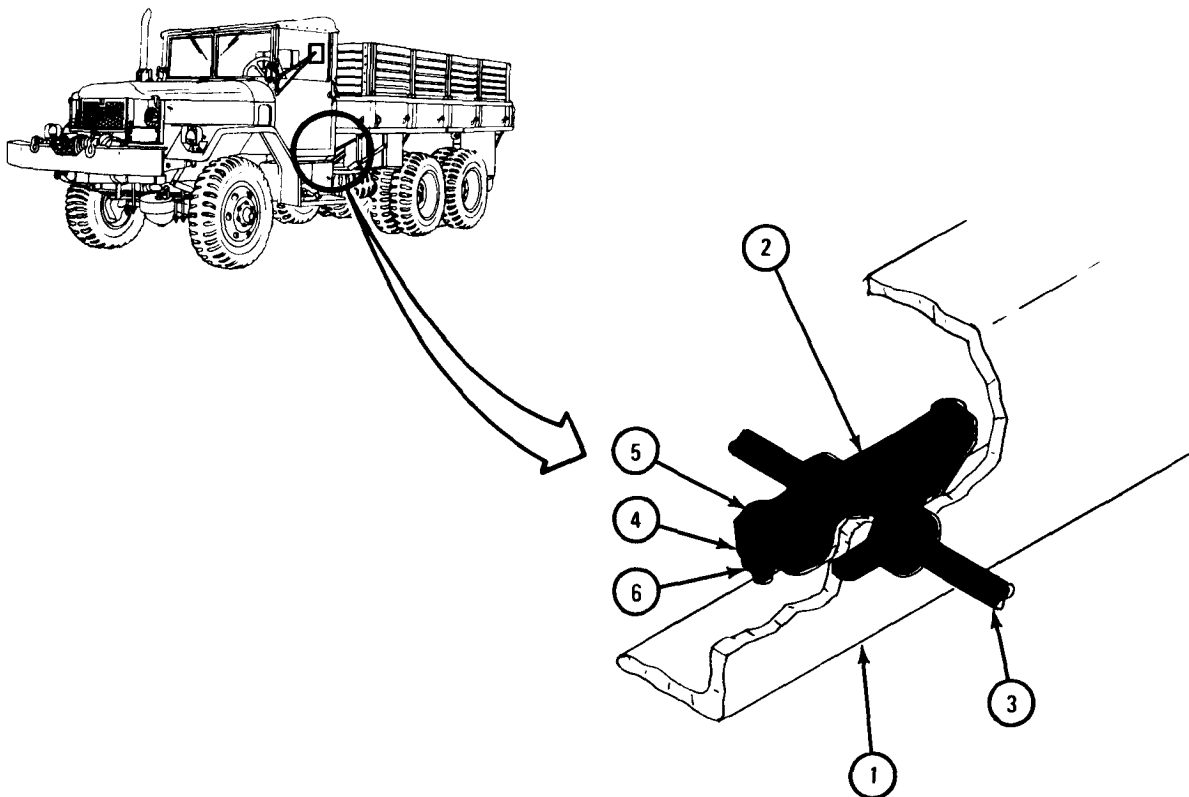

TA 046365

13-6. HANDBRAKE LEVER ASSEMBLY REMOVAL AND REPLACEMENT.

TOOLS: 9/16-inch socket wrench (2)
9/16-inch open end wrench (2)
Long nose pliers
Pliers

SUPPLIES: None

PERSONNEL: One

EQUIPMENT CONDITION: Truck parked, engine off, handbrake off, wheels chocked.

a. Removal.

FRAME 1

1. Using pliers, takeout cotter pin (1).
2. Take away washer (2).
3. Pullout clevis pin (3).

GO TO FRAME 2

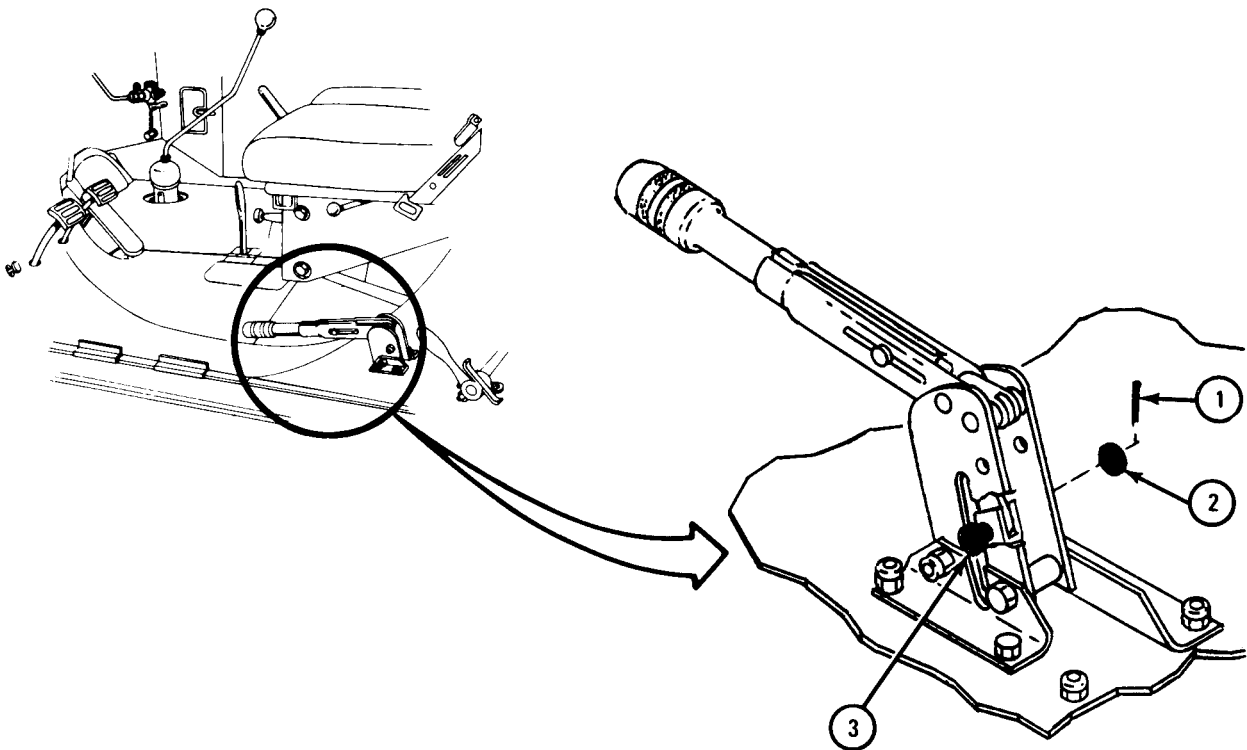

TA 046132

FRAME 2

1. Using 9/16-inch socket wrench, unscrew four nuts (1) from four studs (2).
2. Pull bracket (3) out from under cab.
3. Reach under cab and using 9/16-inch wrench, hold nut (4). Working in cab, using 9/16-inch socket wrench, unscrew screw (5) and take out screw (5) and nut (4).
4. Lift out handbrake lever assembly (6).

GO TO FRAME 3

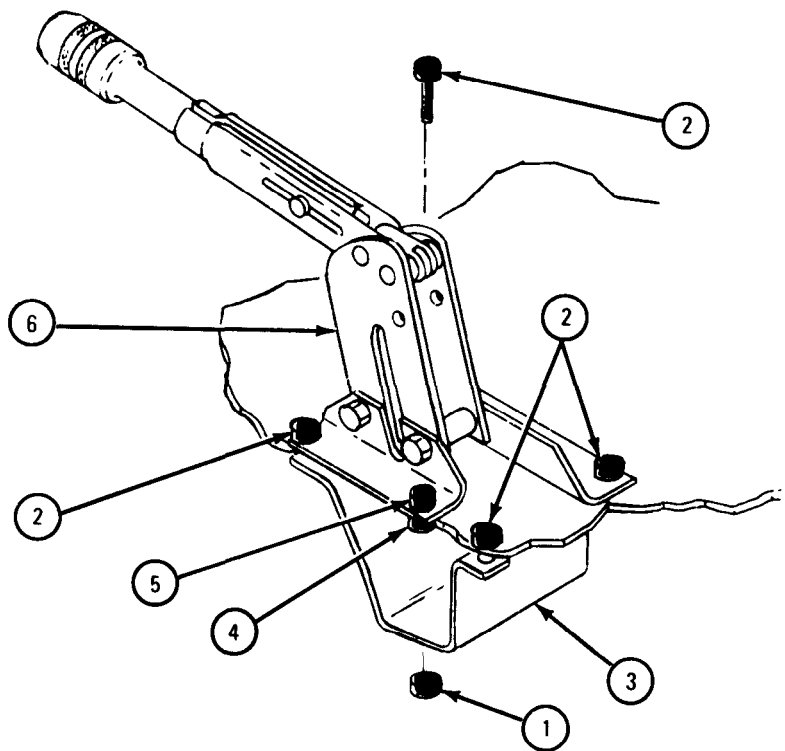

TA 046133

FRAME 3

1. Using socket wrenches, unscrew and take out screw (1), nut (2) and spacer (3).
2. Using 9/16-inch wrenches, unscrew and take off two nuts (4). Take out brackets (5 and 6).
3. Spread open handbrake lever base (7) just enough to take out two screws (8).

END OF TASK

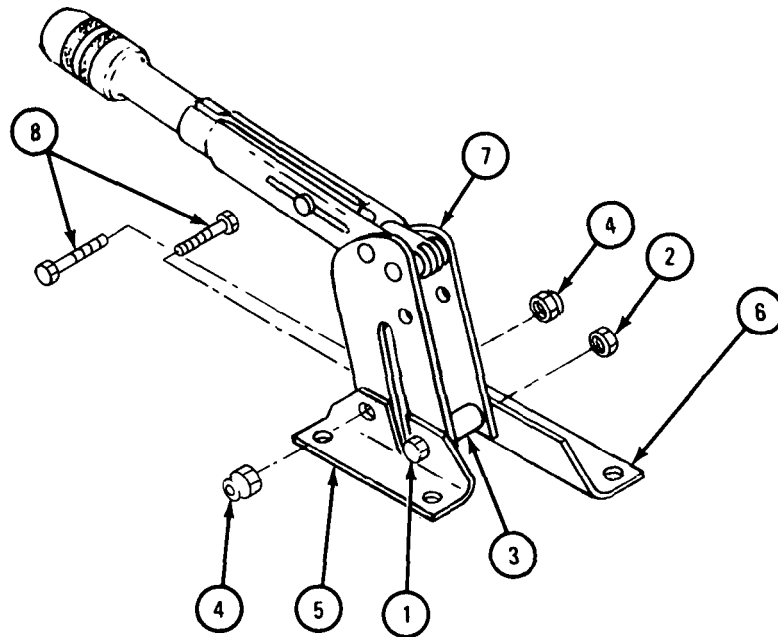

TA 121161

b. Replacement.

FRAME 1

1. Spread open handbrake lever base (1). Put two screws (2) through handbrake lever base from the inside.
2. Put brackets (3 and 4) onto screws (2) and using 9/16-inch wrenches, screw on and tighten two nuts (5).
3. Put spacer (6) into handbrake lever base (1). Put screw (7) through bracket (3), handbrake lever base (1), spacer (6), and bracket (4). Using 9/16-inch wrenches, screw on and tighten nut (8).

GO TO FRAME 2

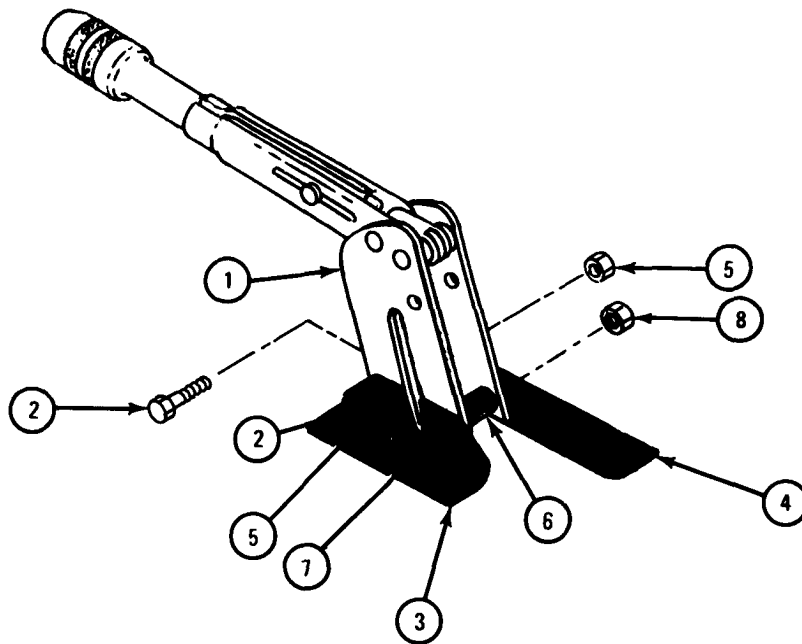

TA 046135

FRAME 2

1. Put handbrake lever assembly (1) in place on floorboard in cab. Line up screw holes.
2. Put screw (2) through bracket (3) and floorboard and reach under cab and start nut (4) on screw. Using 9/16-inch wrench, hold nut. Using 9/16-inch socket wrench, tighten screw into nut.
3. Put bracket (5) under cab with yoke (6) coming up through floorboard. With studs (7) lined with holes in floorboard, start nuts (8) on studs (7).
4. Using 9/16-inch socket wrench, tighten nuts (8).

GO TO FRAME 3

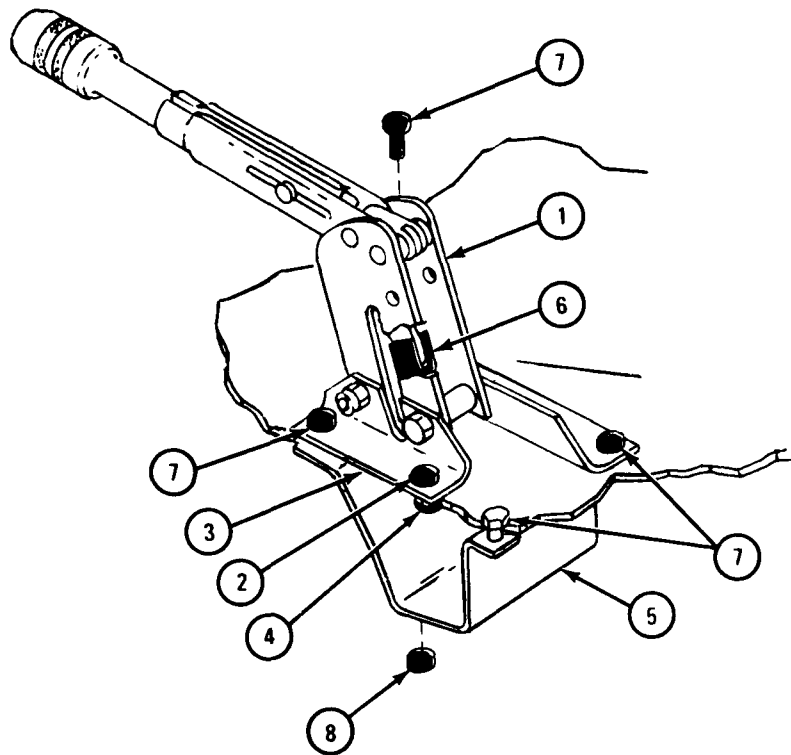

TA 121163

FRAME 3

1. Put handbrake lever (1) in the down position.
2. Using long nose pliers, hold yoke (2) on lever (3).
3. Screw or unscrew handbrake handle (4) until holes in yoke (2) and lever (3) line up. Put clevis pin (5) through holes in yoke and lever.
4. Put washer (6) onto clevis pin (5). Put cotter pin (7) through holes in clevis pin. Using pliers, bend open ends of cotter pin.
5. Screw handbrake handle (4) until it is hand tight.

END OF TASK

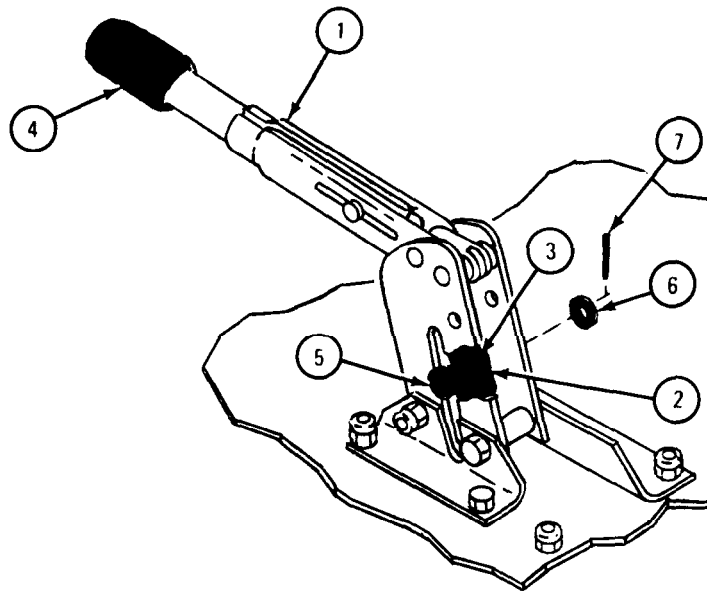

TA 046144

13-7. HANDBRAKE CABLE AND LEVER ASSEMBLY ADJUSTMENT.

TOOLS: 9/16-inch wrench (2) Flat-tip screwdriver
 5/8-inch wrench 7/16-inch wrench
 11/16-inch wrench 1/2-inch wrench
 3/4-inch wrench 9/16-inch open end crowfoot adapter
 0.015-inch feeler gage
 Torque wrench, 150 pound-foot capacity

SUPPLIES: None

PERSONNEL: One

EQUIPMENT CONDITION: Truck parked, engine off, handbrake set, front wheels chocked.

NOTE

If truck has overcenter locking type handbrake lever, do frame 1. If truck has ratchet and pawl type handbrake lever, go to frame 2.

FRAME 1

1. Put handbrake lever (1) all the way down (brake off).
2. Turn cable adjusting knob (2) to left as shown until it stops.

GO TO FRAME 2

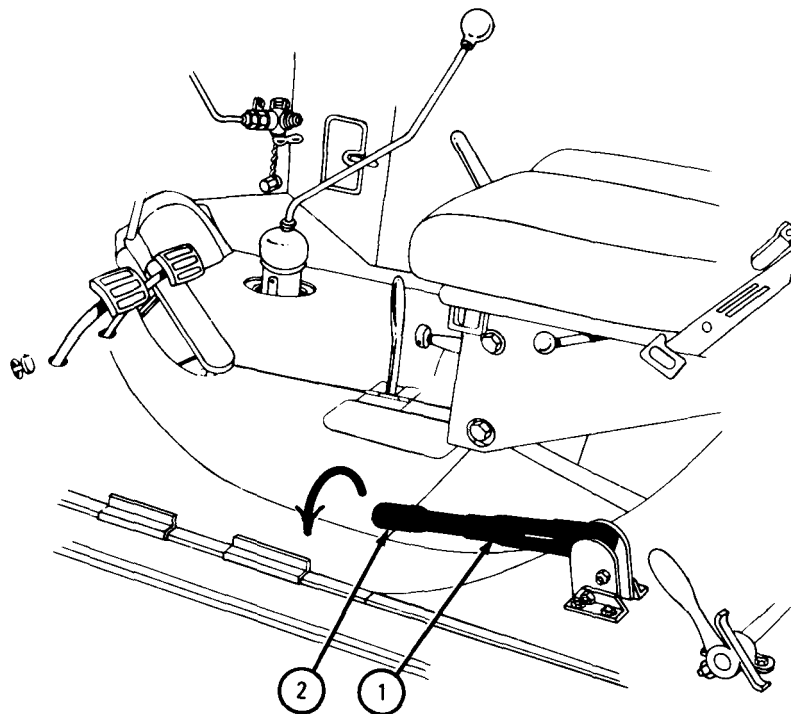

TA 046139

FRAME 2

1. Put handbrake lever (1) all the way down (brake off).
2. Using 7/16-inch and 1/2-inch wrenches, hold nut (2) and unscrew nut (3) until it is almost at the end of cable (4).
3. Using 7/16-inch and 1/2-inch wrenches, hold nut (2) and screw nut (5) until it is tight against pin (6).

GO TO FRAME 3

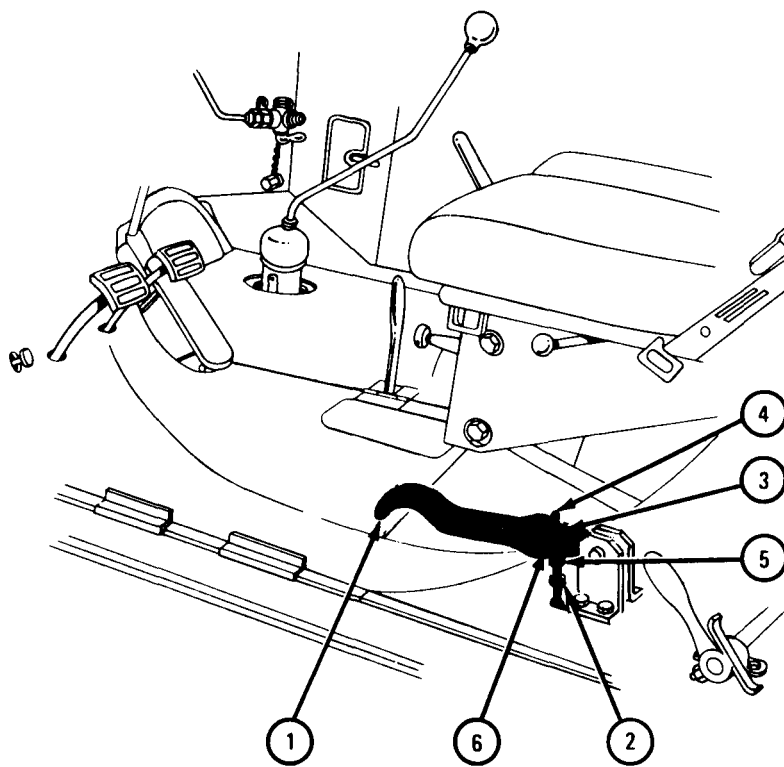

TA 080831

FRAME 3

1. Using 11/16-inch wrench, loosen jamnut (1).
2. Using 0.015-inch feeler gage, check clearance between outer brakeshoe (2) and all along brake drum (3).
3. Using 5/8-inch wrench, screw in adjusting screw (4) until feeler gage just goes in at tightest place.
4. Using 11/16-inch wrench, tighten jamnut (1).
5. Using 0.015-inch feeler gage, check clearance between inner brakeshoe (5) and brake drum (3) all along between points A and B.
6. Using 3/4-inch wrench, turn end-of-cable nut (6) until 0.015-inch feeler gage just goes in at tightest point.

GO TO FRAME 4

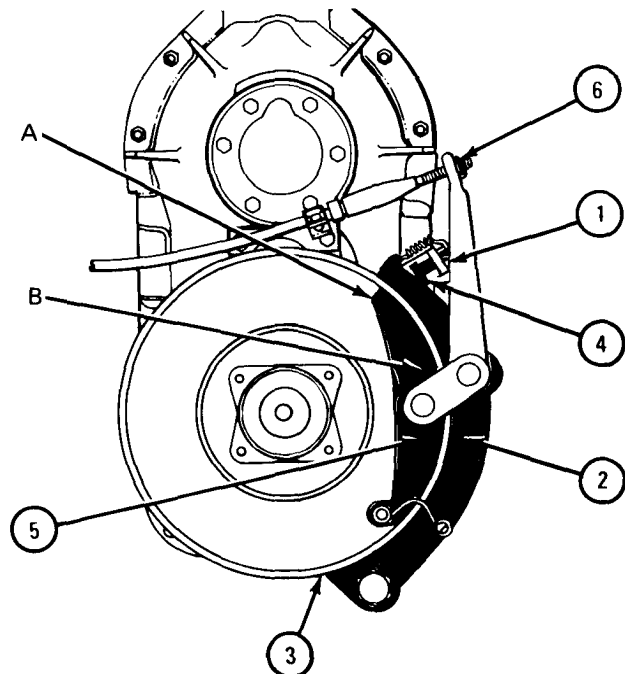
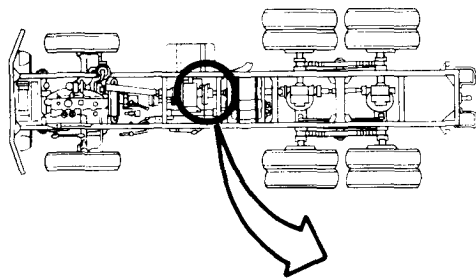

TA 046140

FRAME 4

1. Using screwdriver, hold eccentric pin (1) and using 9/16-inch wrench, loosen nut on other end of pin.
2. Using 0.015-inch feeler gage, check clearance between inner brakeshoe (2) and brake drum (3) all along between points A and B.
3. Using screwdriver, turn eccentric pin (1) until 0.015-inch feeler gage just goes in at tightest point.
4. Using screwdriver, hold eccentric pin (1).
5. Using torque wrench with 9/16-inch crowfoot adapter, tighten nut on other end of eccentric pin (1) to 27 to 35 pound-feet.

GO TO FRAME 5

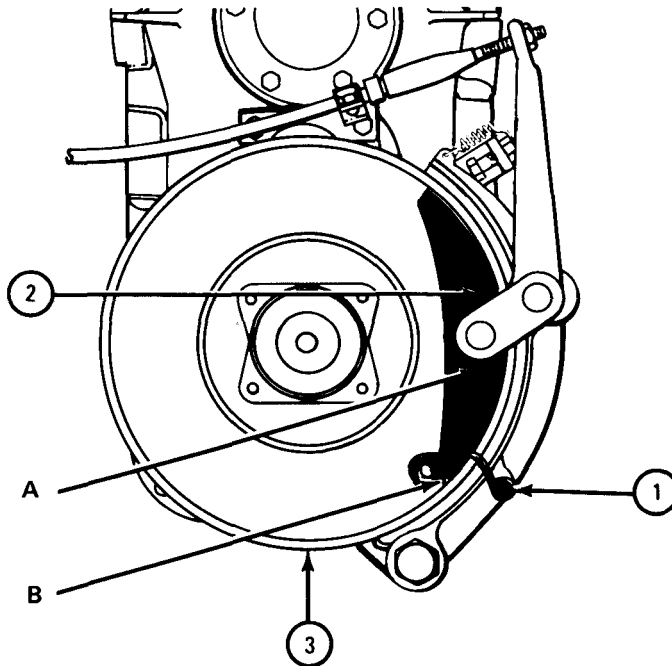

TA 046141

FRAME 5

1. Using 0.015-inch feeler gage, check clearance between inner shoe (1) and brake drum (2) all along between points A and B. If feeler gage just goes in, go to frame 6.
2. Using 3/4-inch wrench, turn end-of-cable nut (3) until 0.015-inch feeler gage just goes in at tightest point.

IF TRUCK HAS RATCHET AND PAWL TYPE HANDBRAKE LEVER, GO TO FRAME 6.
IF TRUCK HAS OVERCENTER LOCKING TYPE HANDBRAKE LEVER, END OF TASK

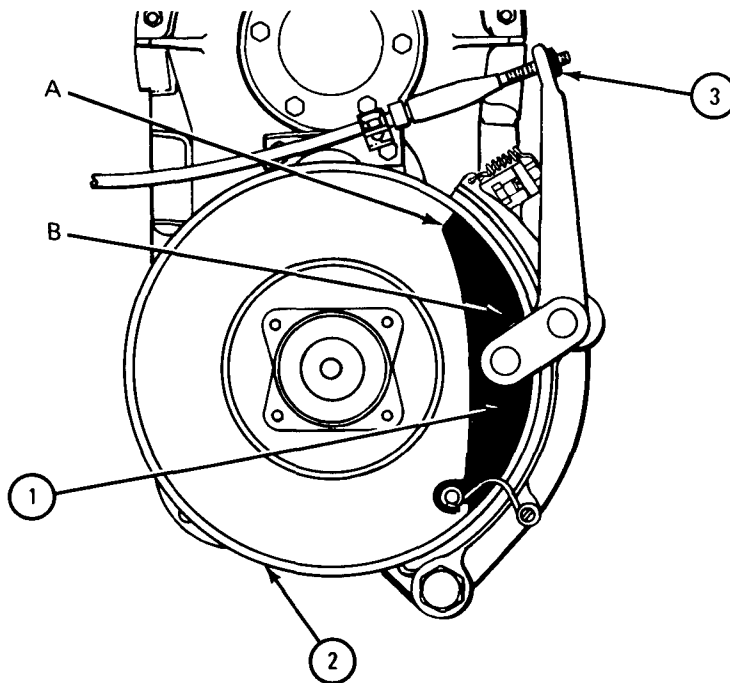

TA 046142

FRAME 6

1. Pull up handbrake lever (1) halfway. If cable (2) is tight, adjustment is correct. If cable is not tight, go to step 2.
2. Push handbrake lever (1) all the way down (brake off).
3. Using 7/16-inch wrench, hold nut (3). Using 1/2-inch wrench, loosen nut (4) one turn.
4. Using 1/2-inch wrench, screw down nut (5) until nut (4) is tight against pin (6).
5. Do step 1 again.

END OF TASK

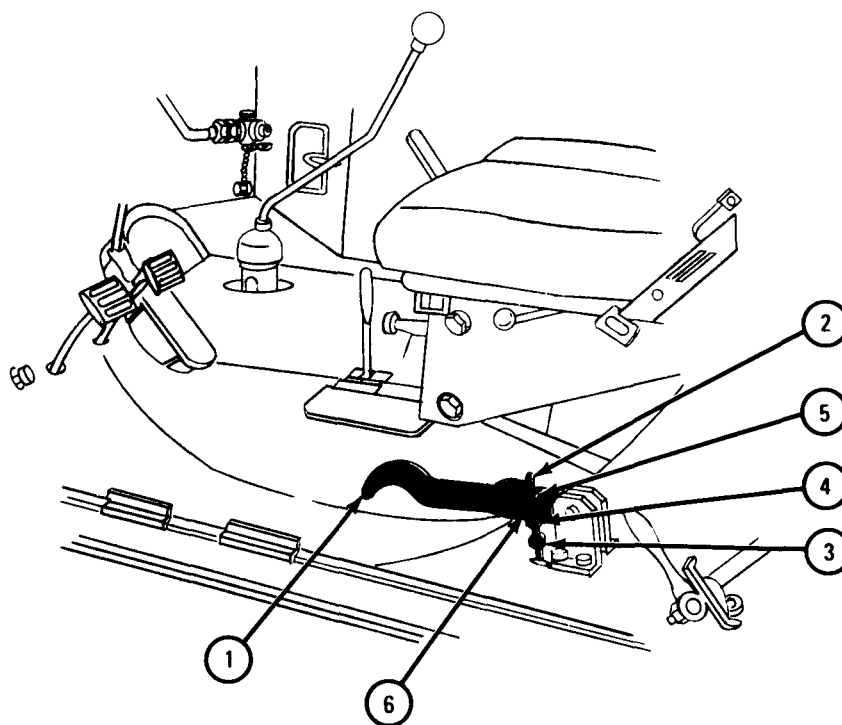

TA 084097

Section III. SERVICE BRAKE

13-8. SERVICE BRAKESHOE ASSEMBLY REMOVAL AND REPLACEMENT.

TOOLS:	3/4-inch wrench (2)	1 1/8-inch box wrench
	1/2-inch wrench	Pliers
	Return spring pliers	Flat nose punch
	Retaining ring tool	Hammer
	Flat-tip screwdriver	11/16-inch wrench

SUPPLIES: None

PERSONNEL: Two

EQUIPMENT CONDITION: Truck parked, engine off, handbrake set.

- a. Preliminary Procedure. Remove hub and brake drum. Refer to para 14-4.
- b. Removal.

FRAME 1

1. Using return spring pliers (1), unhook spring (2) from brakeshoe (3).
 2. Unhook other end of spring (2) and take out spring.
- GO TO FRAME 2

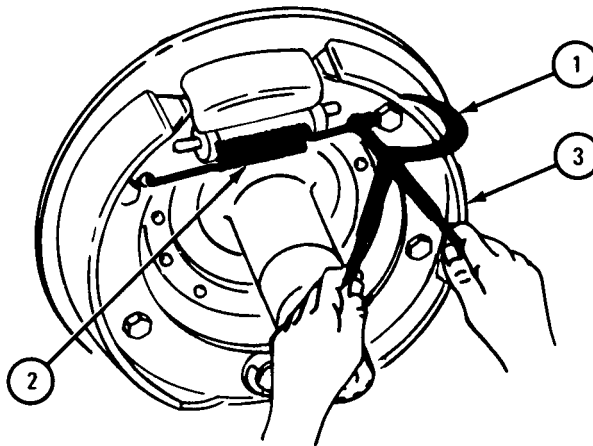

TA 046257

FRAME 2

Soldier A 1. Hold retaining rings (1) with pliers.

Soldier B 2. Using flat nose punch and hammer, tap one end of retaining rings (1) until there is a space at center of rings. Using flat-tip screwdriver, pry off rings.

3. Take off two washers (2).

4. Using 3/4-inch wrenches, hold four guide pins (3) and unscrew and take off four nuts (4) and four lockwashers (5).

GO TO FRAME 3

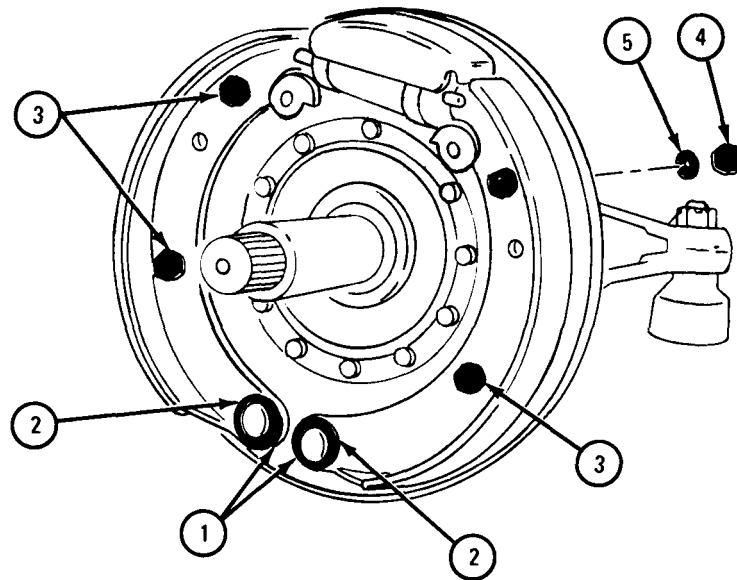

TA 046258

FRAME 3

1. Pull brakeshoes (1 and 2) apart until they are loose from wheel cylinder (3).

NOTE

When taking off brakeshoes (1 and 2) be careful not to lose two springs and two washers from guide pins.

2. Pull brakeshoes (1 and 2) off anchor pins (4).
3. Place brakeshoes (1 and 2) on floor with heads of guide pins (5 and 6) facing down.

GO TO FRAME 4

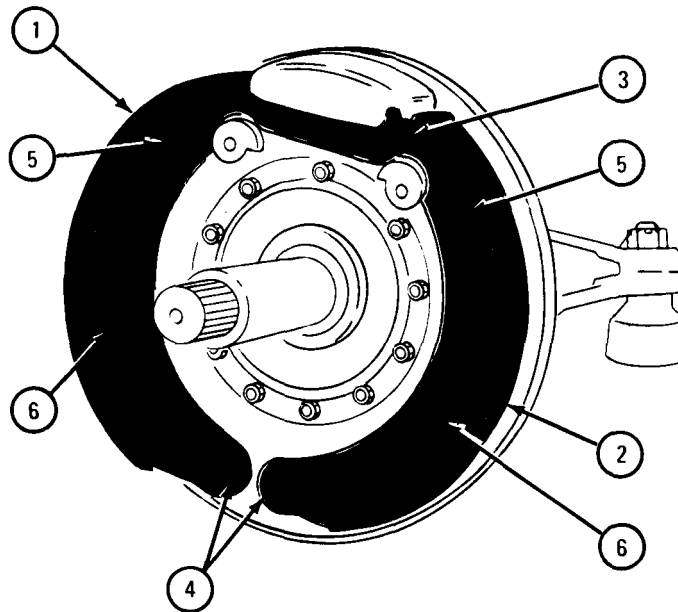

TA 046259

FRAME 4

1. Take anti-rattle springs (1) off two long guide pins (2). Using retaining ring tool, take off retaining rings (3).
2. Take off lower washers (4) from two short guide pins (5).
3. Pick up brakeshoes (6 and 7) and take away guide pins (2 and 5) from other side in four places.

GO TO FRAME 5

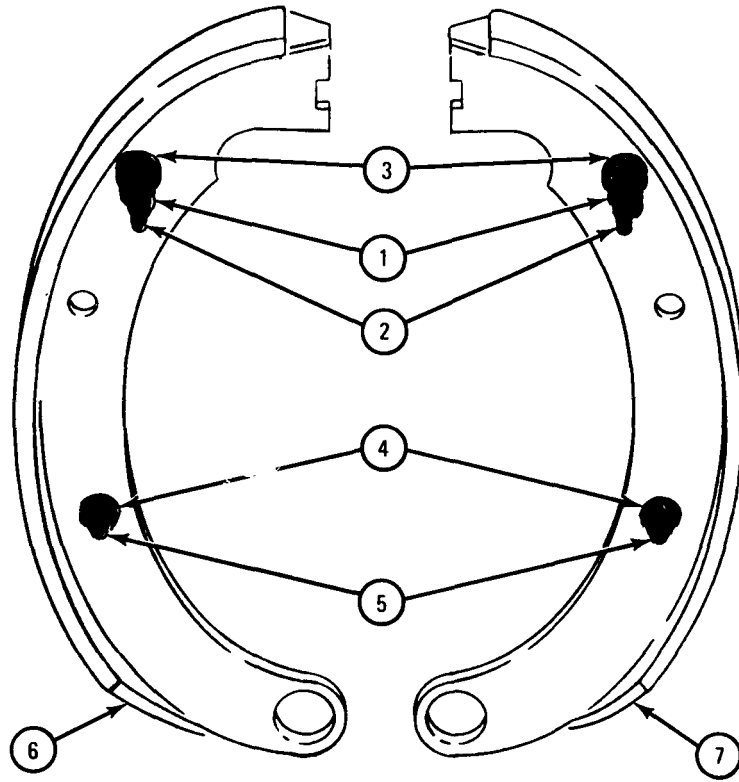

TA 046260

FRAME 5

1. Take off two felt washer retainers (1). Take off two felt washers (2).
- END OF TASK

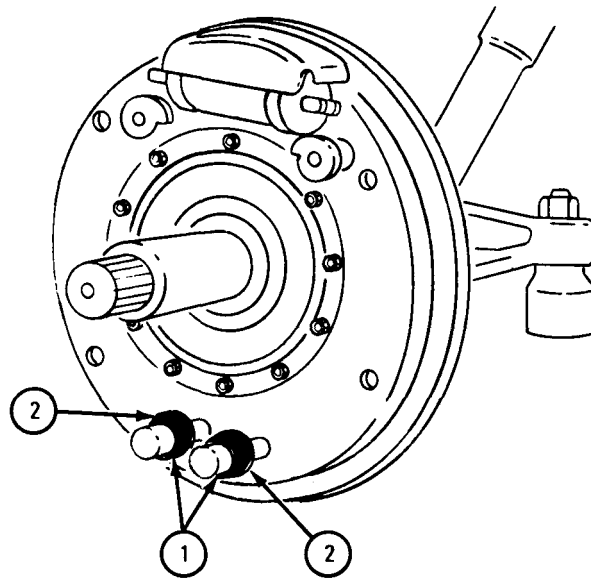

TA 046261

c. Replacement.

FRAME 1 1

1. Put felt washer (1) on anchor pins (2) in two places. Put felt washer retainers (3) on in two places.

GO TO FRAME 2

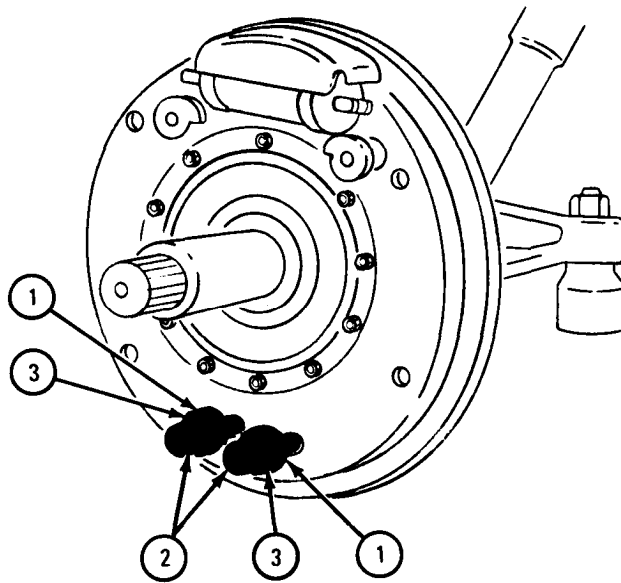

TA 046262

FRAME 2

1. Put long guide pins (1) into brakeshoes (2 and 3) from other side in two places. Using retaining ring tool, put on retaining rings (4). Put on anti-rattle springs (5).
2. Put short guide pins (6) into brakeshoes (2 and 3) from other side in two places. Put on lower washers (7).

GO TO FRAME 3

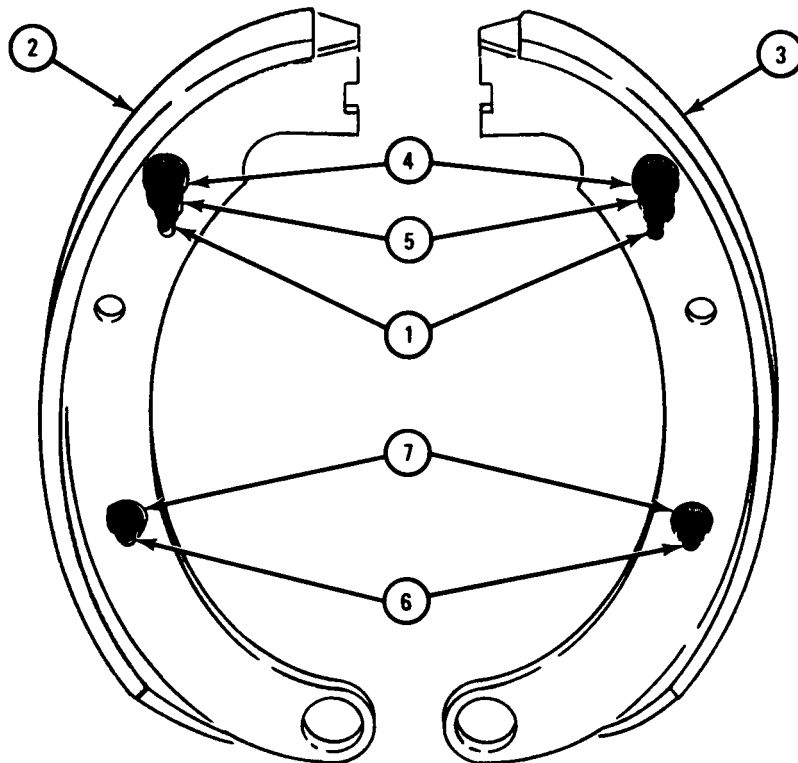

TA 046263

FRAME 3

1. Put brakeshoe (1) on anchor pin (2). Put brakeshoe (3) on anchor pin (4). Put upper part of brakeshoes in slots in cylinder rods (5).
2. Push long guide pins (6) and short guide pins (7) through holes in flange plate (8).

GO TO FRAME 4

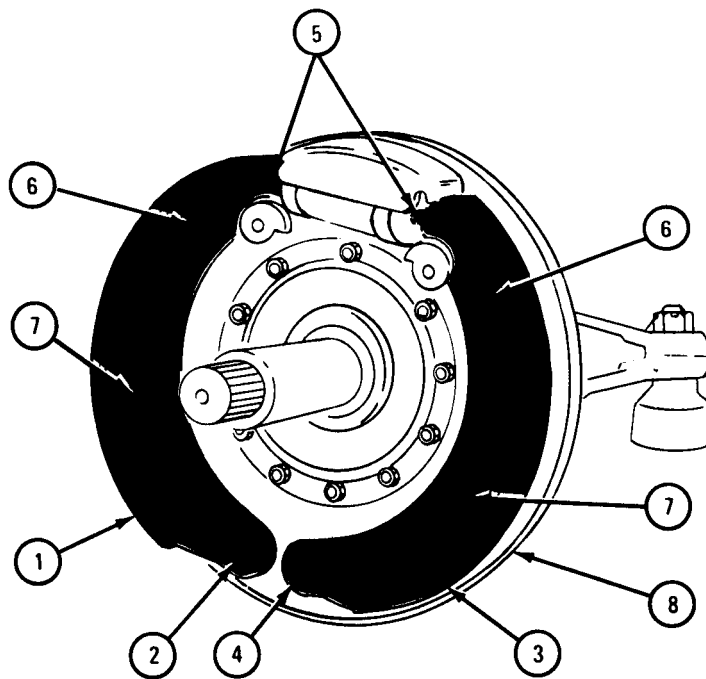

TA 046264

FRAME 4

1. Put flat washers (1) on anchor pins (2). Using retaining ring tool, put retaining rings (3) on anchor pins.
2. Using 3/4-inch wrench, hold four guide pins (4 and 5). Put on four lockwashers (6) and four nuts (7).
3. Using 1/2-inch wrench, screw on and tighten four nuts (7).

GO TO FRAME 5

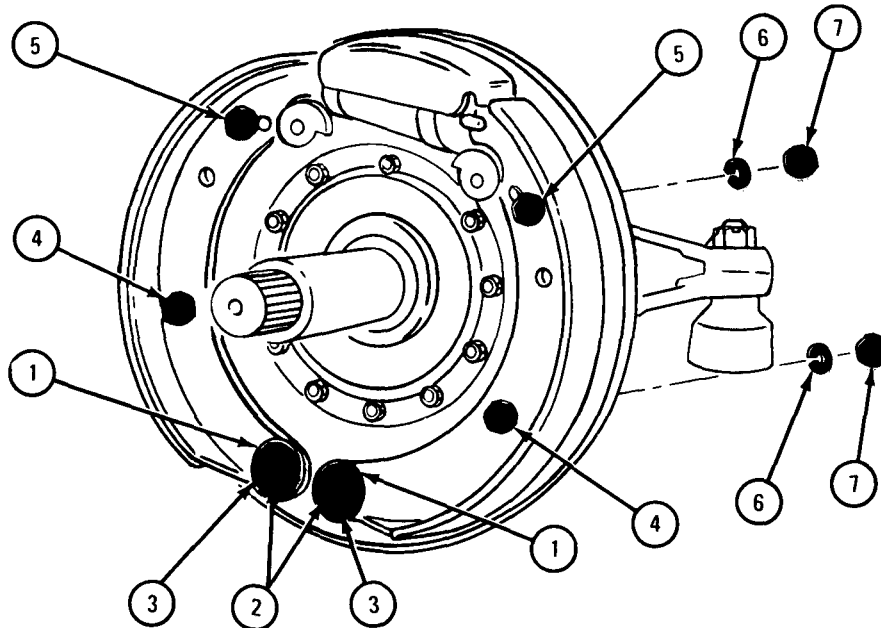

TA 046265

FRAME 5

1. Hook spring end (1) in hole in brakeshoe next to long guide pin (2). Using return spring pliers, hook return spring end (3) in hole in brakeshoe next to long guide pin (4).

GO TO FRAME 6

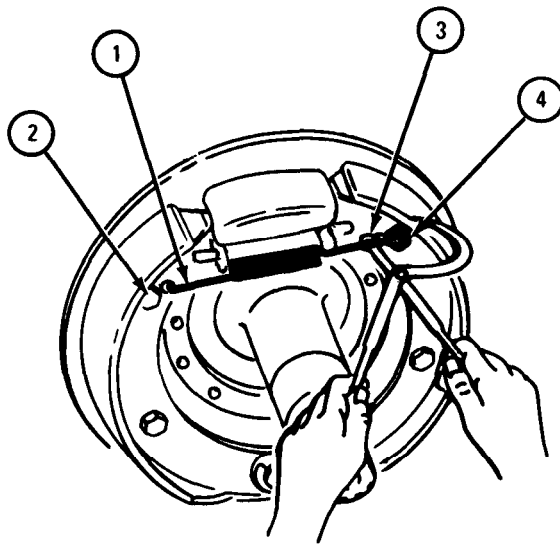

TA 046266

FRAME 6

1. Using 1 1/8-inch box wrench, loosen and hold jamnut (1). Using 1/2-inch open end wrench, turn anchor pin (2) until punch mark (3) is in position shown.
2. Using 1/2-inch open end wrench, hold anchor pin (2). Using 1 1/8-inch box wrench, tighten jamnut (1).
3. Using 1 1/8-inch box wrench, loosen and hold jamnut (4).
4. Using 1/2-inch open end wrench, turn anchor pin (5) until punch mark is in position shown.
5. Using 1/2-inch open end wrench, hold anchor pin (5). Using 1 1/8-inch box wrench, tighten jamnut (4).

GO TO FRAME 7

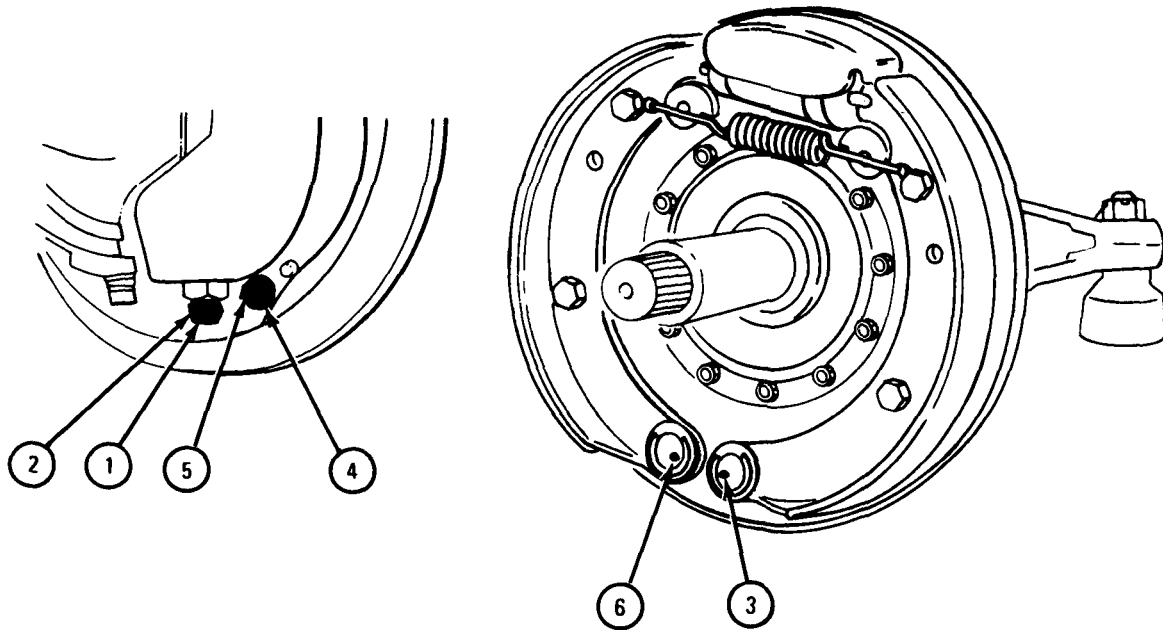

TA 046267

FRAME 7

1. Using 11/16-inch wrench, turn adjusting cam (1) until cam (2) is as shown.
2. Using 11/16-inch wrench, turn adjusting cam (3) until cam (4) is as shown.

NOTE

Follow-on Maintenance Action Required:

1. Replace hub and brake drum. Refer to para 14-4.
2. Perform major service brake adjustment. Refer to para 13-10.

END OF TASK

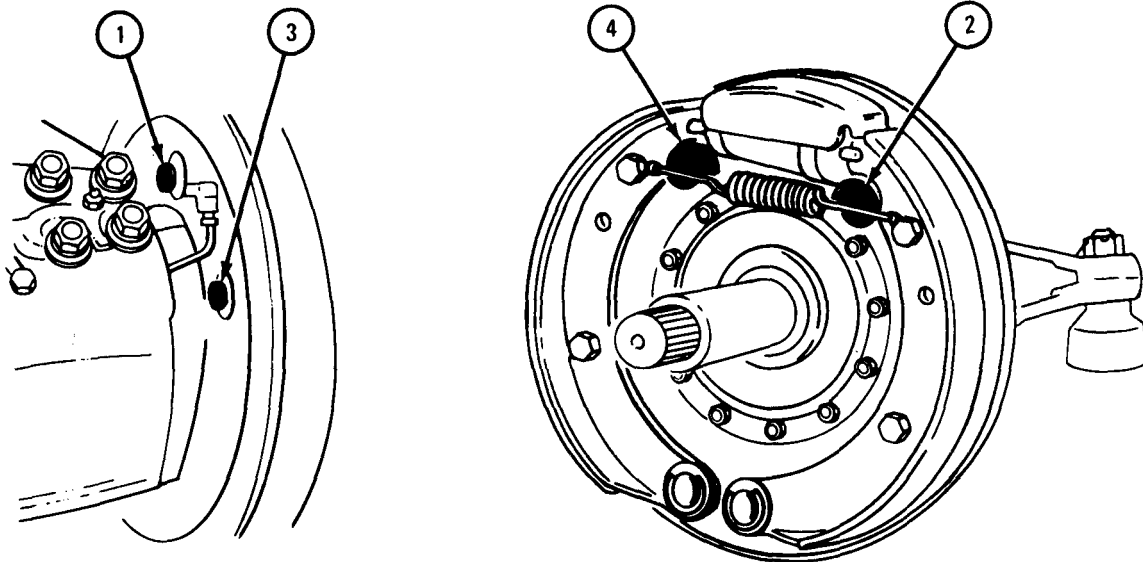

TA 046268

13-9. SERVICE BRAKES MINOR ADJUSTMENT.

NOTE

This task is the same for all six wheels of the truck.

TOOLS: Safety jack
 Chocks (4)
 11/16-inch wrench

SUPPLIES: None

PERSONNEL: One

EQUIPMENT CONDITION: Truck parked, engine off, handbrake set.

FRAME 1

1. Check wheel bearing adjustment. Refer to para 14-3.

CAUTION

Do not adjust brakes if the wheel bearing adjustment is bad or the brakes are hot.

2. Jack up truck and put safety jack under frame. Jack truck down onto safety jack. Refer to para 11-4.
3. Place chocks (1) at wheels that are still on ground.

GO TO FRAME 2

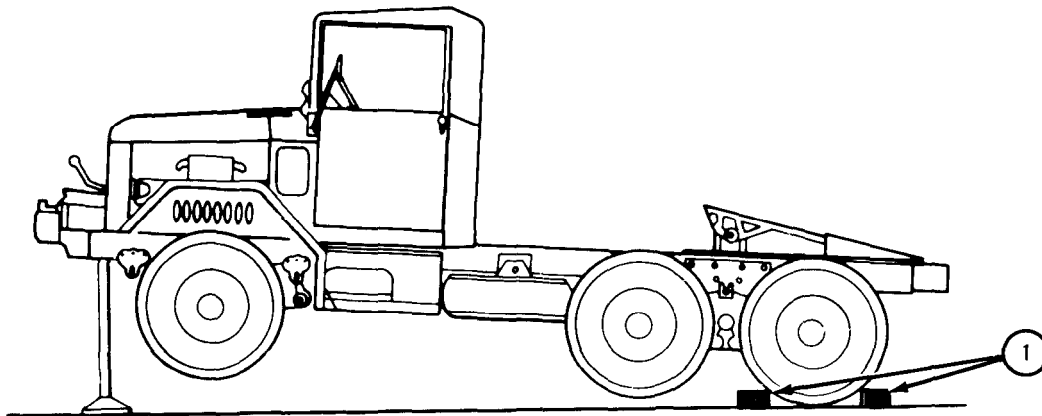

TA 046145

FRAME 2

1. Turn wheel (1) by hand. Using 11/16-inch wrench, turn cam (2) the way the arrow shows until wheel drags.
2. Turn wheel (1) by hand. Using 11/16-inch wrench, turn cam (2) the other way until wheel stops dragging.
3. Turn wheel (1) by hand. Using 11/16-inch wrench, turn cam (3) the way the arrow shows until wheel drags.
4. Turn wheel (1) by hand. Using 11/16-inch wrench, turn cam (3) the other way until wheel stops dragging.
5. Jack up truck and take away safety jack. Jack truck down. Refer to Part 1, para 11-4.
6. Take chocks away from truck.

END OF TASK

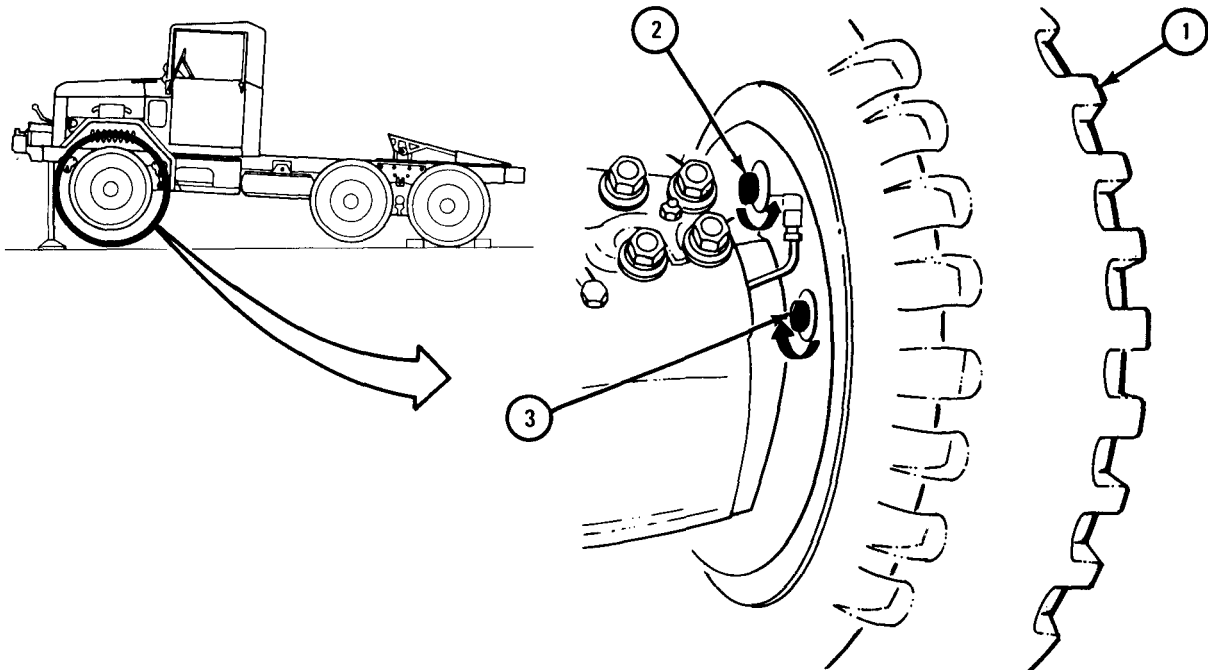

TA 046161

13-10. SERVICE BRAKES MAJOR ADJUSTMENT.

NOTE

This task is the same for all six wheels of the truck.

TOOLS:	Safety jack	0.010-inch	feeler	gage
	Chocks	0.020-inch	feeler	gage
	9/16-inch open end wrench	1/2-inch	open end	wrench
	1 1/8-inch box end wrench	1 1/16-inch	open end	wrench

SUPPLIES: None

PERSONNEL: One

EQUIPMENT CONDITION: Truck parked, engine off, handbrake set.

FRAME 1

1. Check wheel bearing adjustment. Refer to para 14-3.

CAUTION

Do not adjust brakes if the wheel bearing adjustment is bad or the brakes are hot.

2. Remove wheel. Place safety jack under frame. Refer to TM 9-2320-209-10.
3. Place chocks (1) at wheels that are still on ground.

GO TO FRAME 2

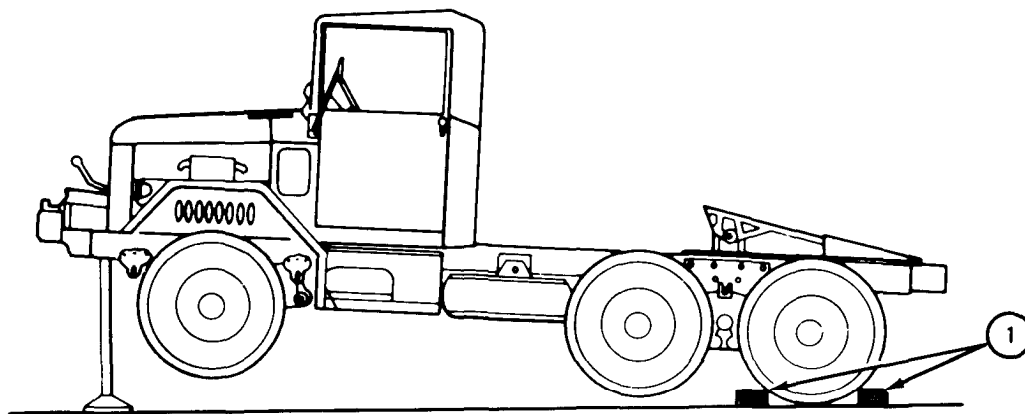

TA 101529

FRAME 2

1. Using 9/16-inch wrench, unscrew and take off nut (1). Take off lockwasher (2) and inspection cover (3).

GO TO FRAME 3

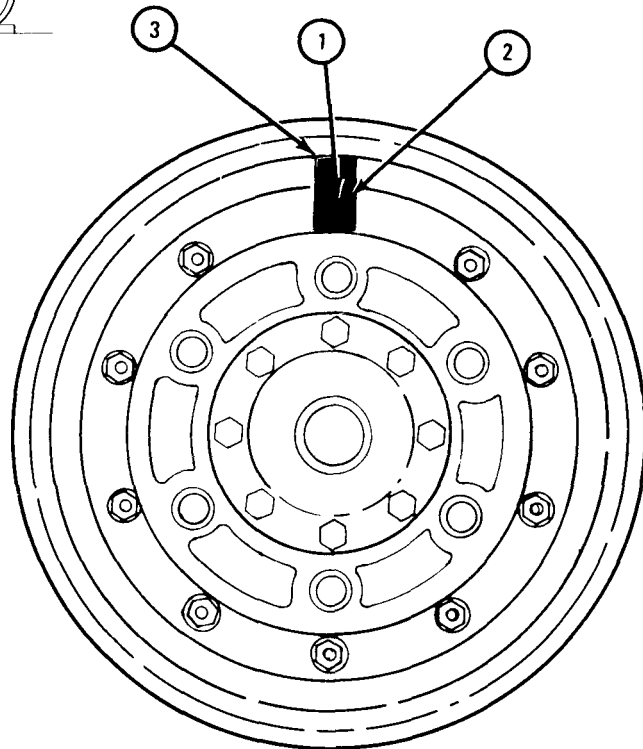
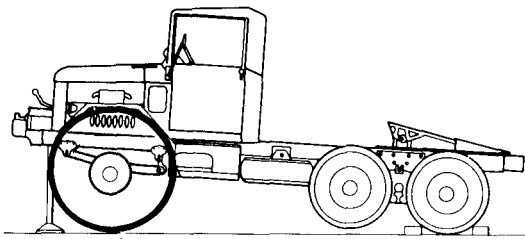

TA 046146

FRAME 3

1. Turn brake drum (1) until inspection hole (2) is at bottom of left brake lining.
2. Put 0.010-inch feeler gage in inspection hole (2) so it is between brake lining (3) and inside of brake drum (4).
3. Using 1 1/8-inch box wrench, loosen and hold jamnut (5). Using 1/2-inch open end wrench, turn anchor pin (6) to right until feeler gage just goes in easily and can be pulled out with drag.
4. Using 1/2-inch open end wrench, hold anchor pin (6). Using 1 1/8-inch box wrench, tighten jamnut (5).

GO TO FRAME 4

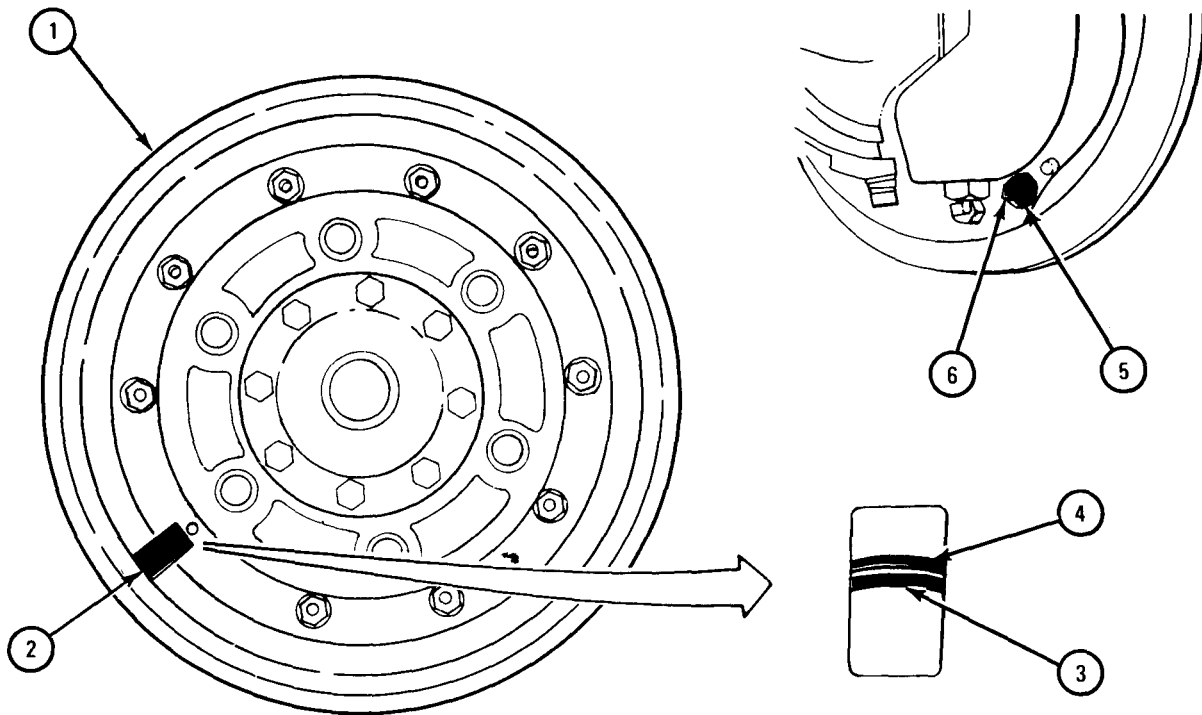

TA 046147

FRAME 4

1. Turn brake drum (1) until inspection hole (2) is at top of left brake lining.
2. Put 0.020-inch feeler gage in inspection hole (2) so it is between brake lining (3) and inside of brake drum (4).
3. Using 11/16-inch wrench, turn cam (5) to right until feeler gage just goes in easily and can be pulled out with drag.

GO TO FRAME 5

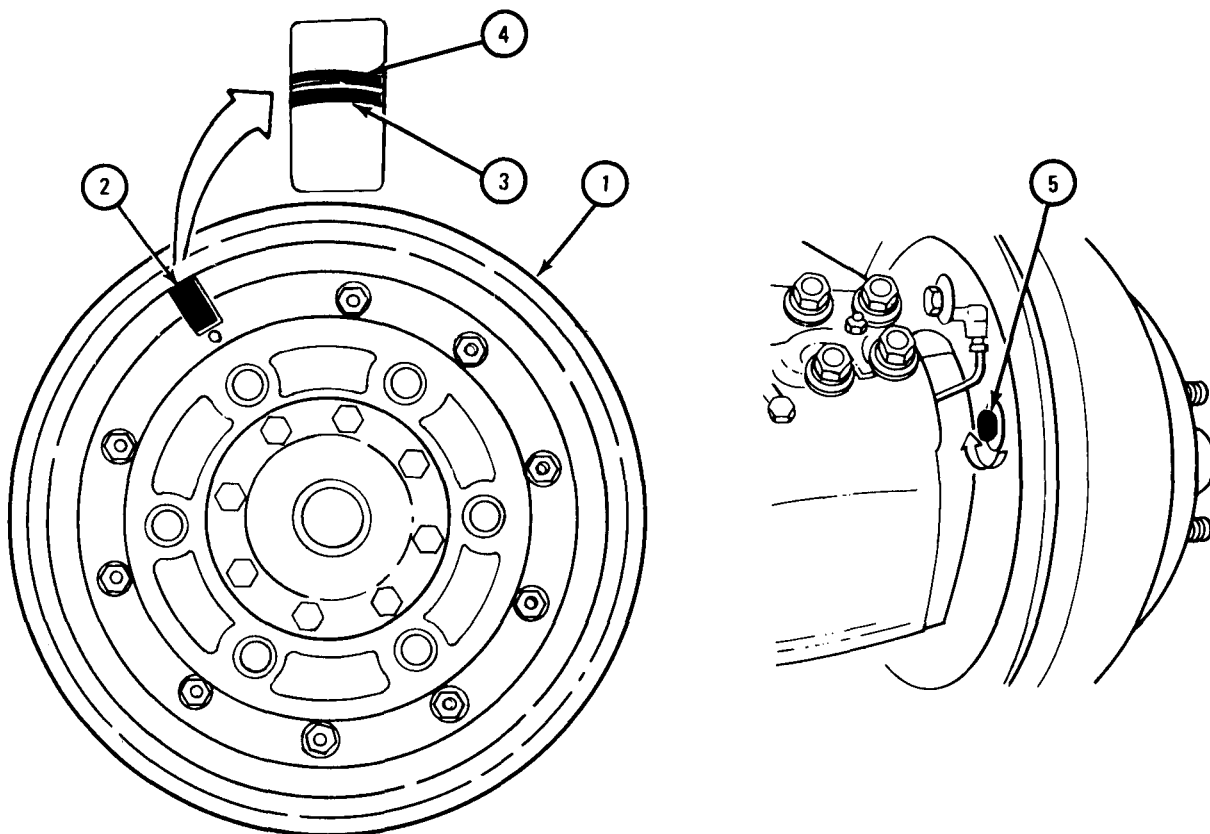

TA 046148

FRAME 5

1. Turn brake drum (1) until inspection hole (2) is at bottom of left brake lining.
2. Put 0.010-inch feeler gage in inspection hole (2) so it is between brake lining (3) and inside of brake drum (4) and can be pulled out with drag.
3. If feeler gage just goes in easily, take feeler gage away and go to frame 6. If it does not, go to step 4.
4. Using 1 1/8-inch box wrench, loosen and hold jamnut (5). Using 1/2-inch open end wrench, turn anchor pin (6) to right until feeler gage just goes in easily and can be pulled out with drag.
5. Using 1/2-inch open end wrench, hold anchor pin (6). Using 1 1/8-inch box wrench, tighten jamnut (5).

GO TO FRAME 6

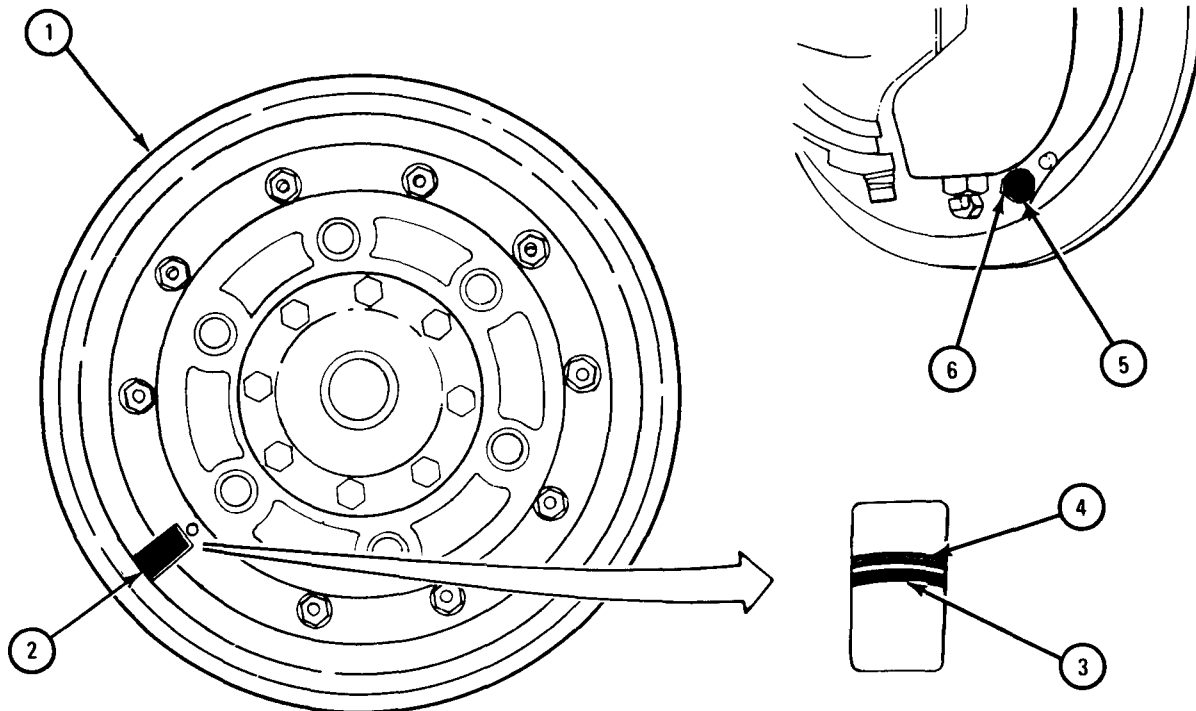

TA 046147

FRAME 6

1. Turn brake drum (1) until inspection hole (2) is at bottom of right brake lining.
2. Put 0.010-inch feeler gage in inspection hole (2) so it is between brake lining (3) and inside of brake drum (4).
3. Using 1 1/8-inch box wrench, loosen and hold jamnut (5). Using 1/2-inch open end wrench, turn anchor pin (6) to left until feeler gage just goes in easily and can be pulled out with drag.
4. Using 1/2-inch open end wrench, hold anchor pin (6). Using 1 1/8-inch box wrench, tighten jamnut (5).

GO TO FRAME 7

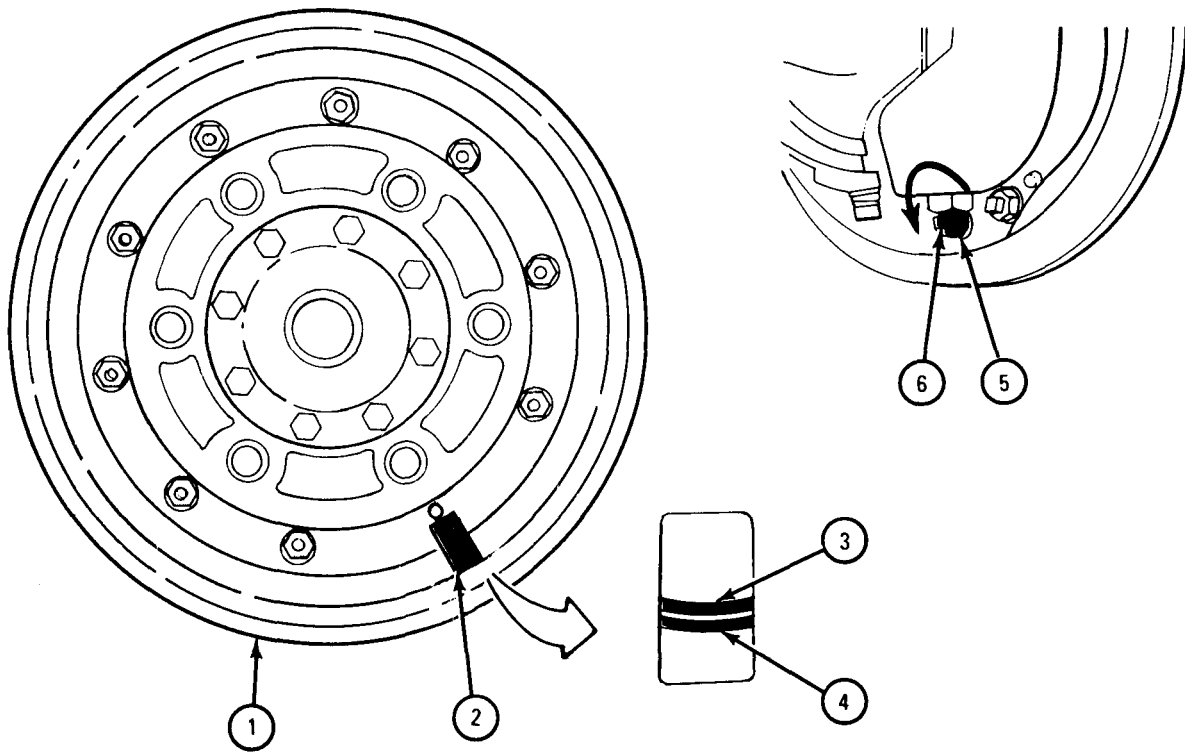

TA 046149

FRAME 7

1. Turn brake drum (1) until inspection hole (2) is at top of right brake lining.
2. Put 0.20-inch feeler gage in inspection hole (2) so it is between brake lining (3) and inside of brake drum (4).
3. Using 11/16-inch wrench, turn cam (5) to left until feeler gage just goes in easily and can be pulled out with drag.

GO TO FRAME 8

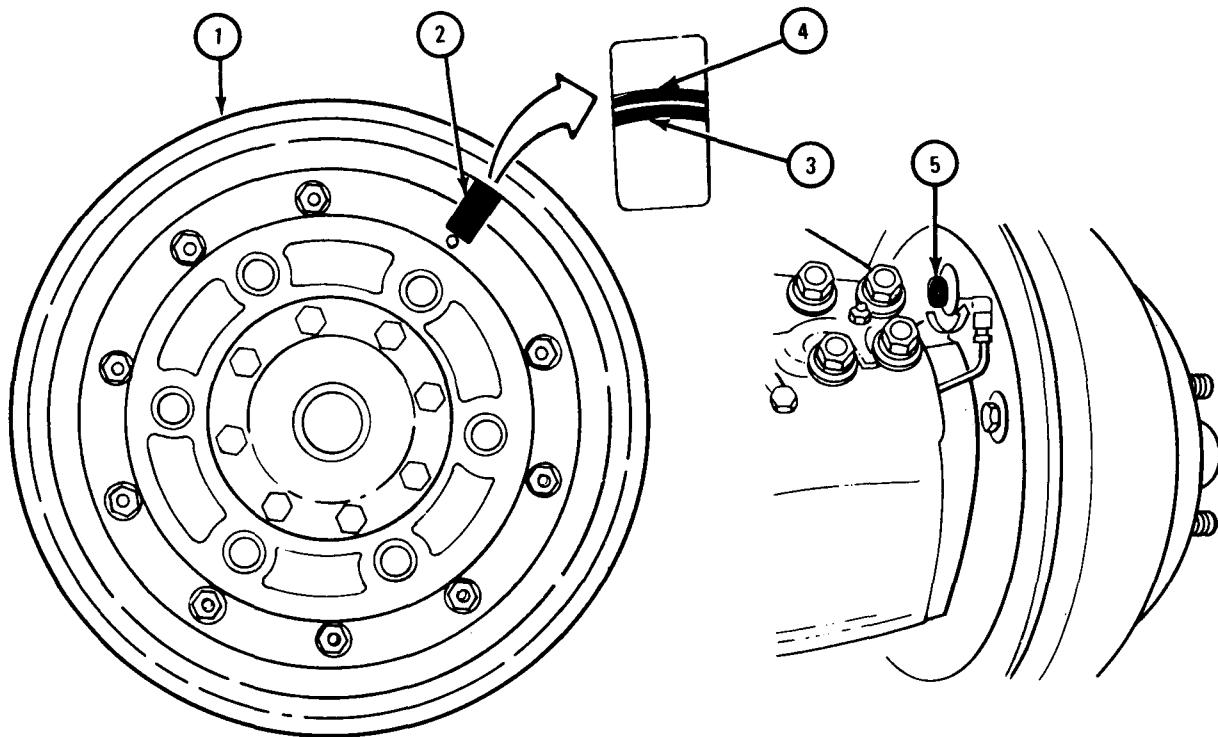

TA 046150

FRAME 8

1. Turn brake drum (1) until inspection hole (2) is at bottom of right brake lining.
2. Put 0.010-inch feeler gage in inspection hole (2) so it is between brake lining (3) and inside of brake drum (4) and can be pulled out with drag.
3. If feeler gage just goes in easily, take feeler gage away and put cover on inspection hole (2). Then go to frame 9. If it does not, go to step 4.
4. Using 1 1/8-inch box wrench, loosen and hold jamnut (5). Using 1/2-inch open end wrench, turn anchor pin (6) to left until feeler gage just goes in easily and can be pulled out with drag.
5. Using 1/2-inch open end wrench, hold anchor pin (6). Using 1 1/8-inch box wrench, tighten jamnut (5).

GO TO FRAME 9

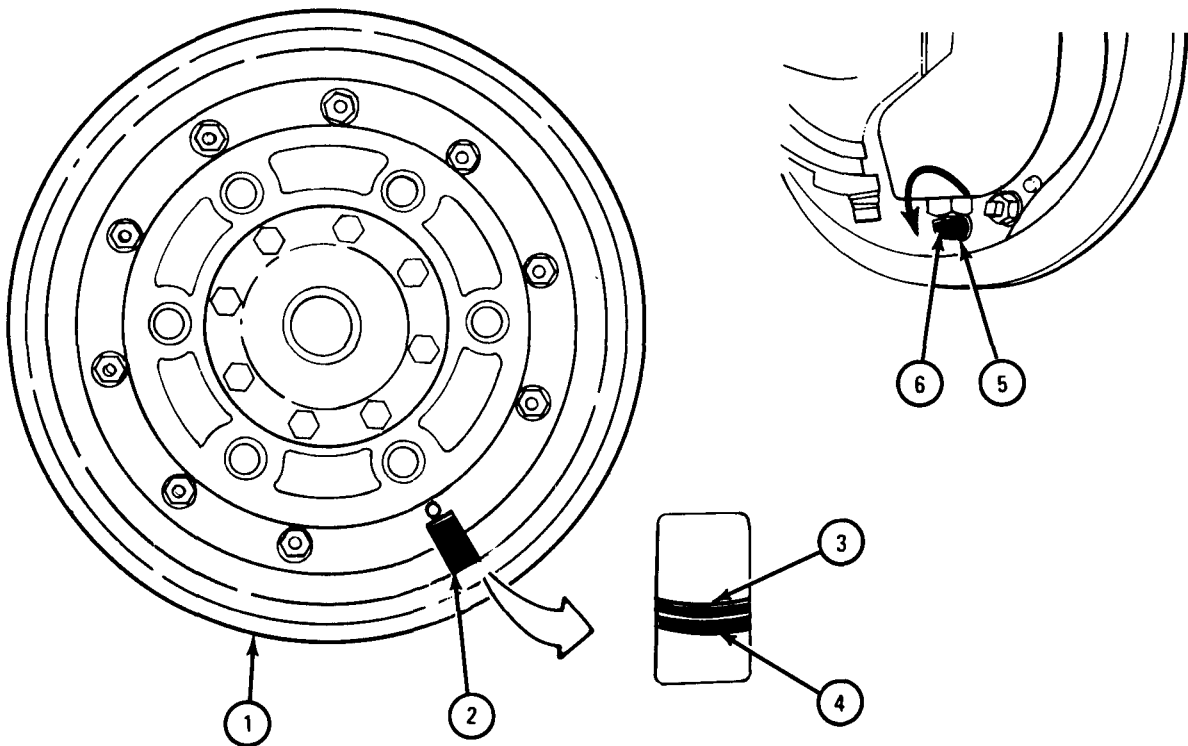

TA 046149

FRAME 9

1. Put inspection cover (1) on screw (2).
 2. Put lockwasher (3) on screw (2). Using 9/16-inch wrench, screw on nut (4).
- GO TO FRAME 10

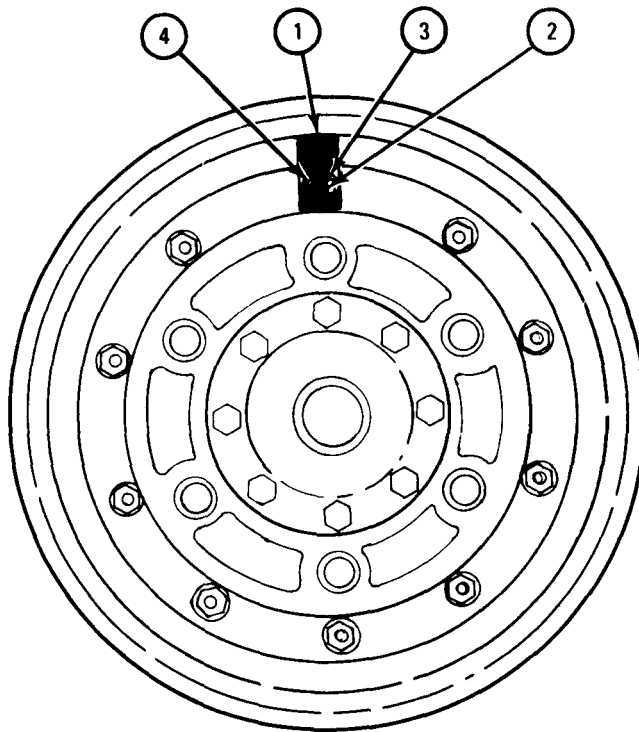

TA 046152

FRAME 10

1. Turn brake drum (1) by hand. Using 11/16-inch wrench, turn cam (2) the way the arrow shows until brake drum drags.
2. Turn brake drum (1) by hand, and using 11/16-inch wrench, turn cam (2) the other way until brake drum stops dragging.
3. Turn brake drum (1) by hand, and using 11/16-inch wrench, turn cam (3) the way the arrow shows until brake drum drags.
4. Turn brake drum (1) by hand, and using 11/16-inch wrench, turn cam (3) the other way until brake drum stops dragging.
5. Put wheel on truck. Refer to TM 9-2320-209-10.
6. Jack up truck. Take safety jack away from truck. Jack truck down. Refer to TM 9-2320-209-10.
7. Take chocks away from truck.

END OF TASK

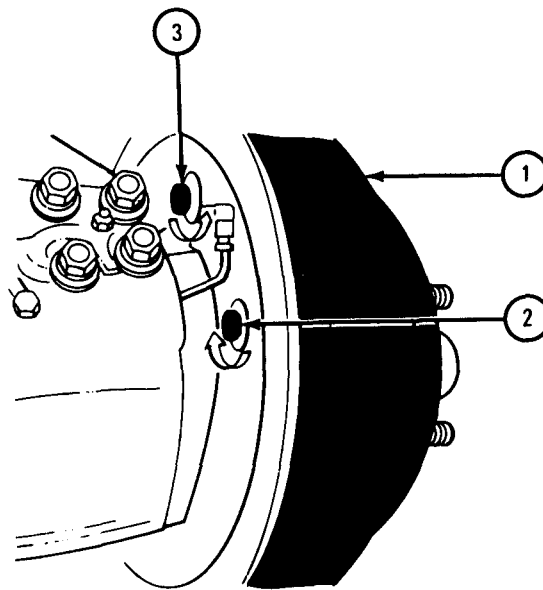

TA 101530

Section IV. HYDRAULIC BRAKE SYSTEM

13-11. HYDRAULIC WHEEL CYLINDER REMOVAL AND REPLACEMENT.

TOOLS: 7/16-inch wrench
9/16-inch wrench
Return spring pliers

SUPPLIES: None

PERSONNEL: One

EQUIPMENT CONDITION: Truck parked, engine off, handbrake set, wheels chocked.

a. Preliminary Procedure. Remove hub and brake drum assembly. Refer to para 14-4.

b. Removal.

FRAME 1

1. Using return spring pliers (1), unhook spring (2) from brakeshoe (3).
GO TO FRAME 2

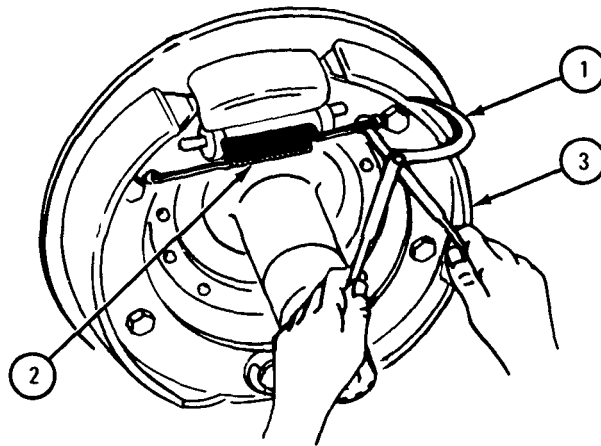

TA 046257

FRAME 2

1. Using 7/16-inch wrench, unscrew and take off hydraulic line fitting (1).
 2. Using 9/16-inch wrench, unscrew and take off two screws (2).
 3. Take off two lockwashers (3).
 4. On the brakeshoe side of wheel, take off dust shield (4) and wheel cylinder (5).
- END OF TASK

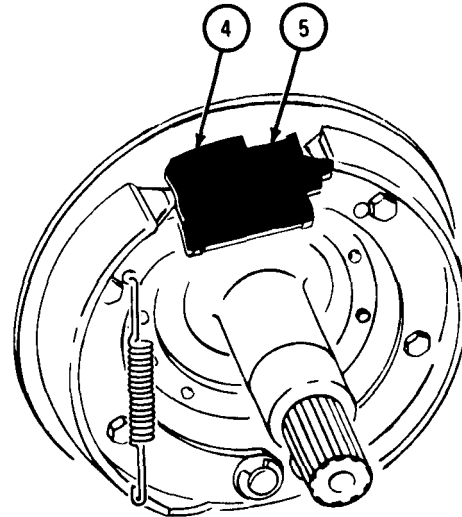
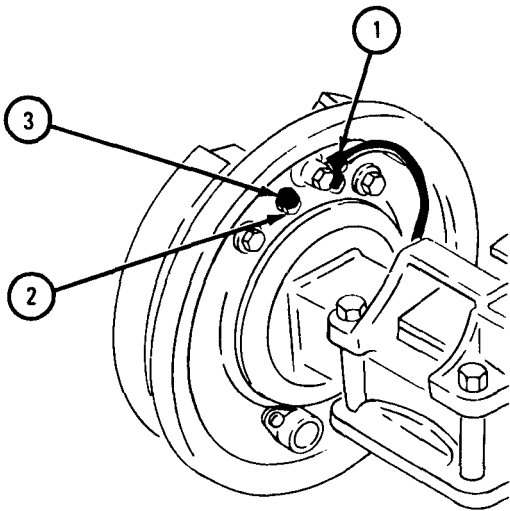

TA 046284

c. Replacement.

FRAME 1

1. Put dust guard (1) over wheel cylinder (2) and into flange plate (3).
2. On the back side of wheel, put two lockwashers (4) on two screws (5). Start screws into wheel cylinder. Using 9/16-inch wrench, tighten screws.
3. Put brakeshoes (6) in slots in rods of wheel cylinder (7).

GO TO FRAME 2

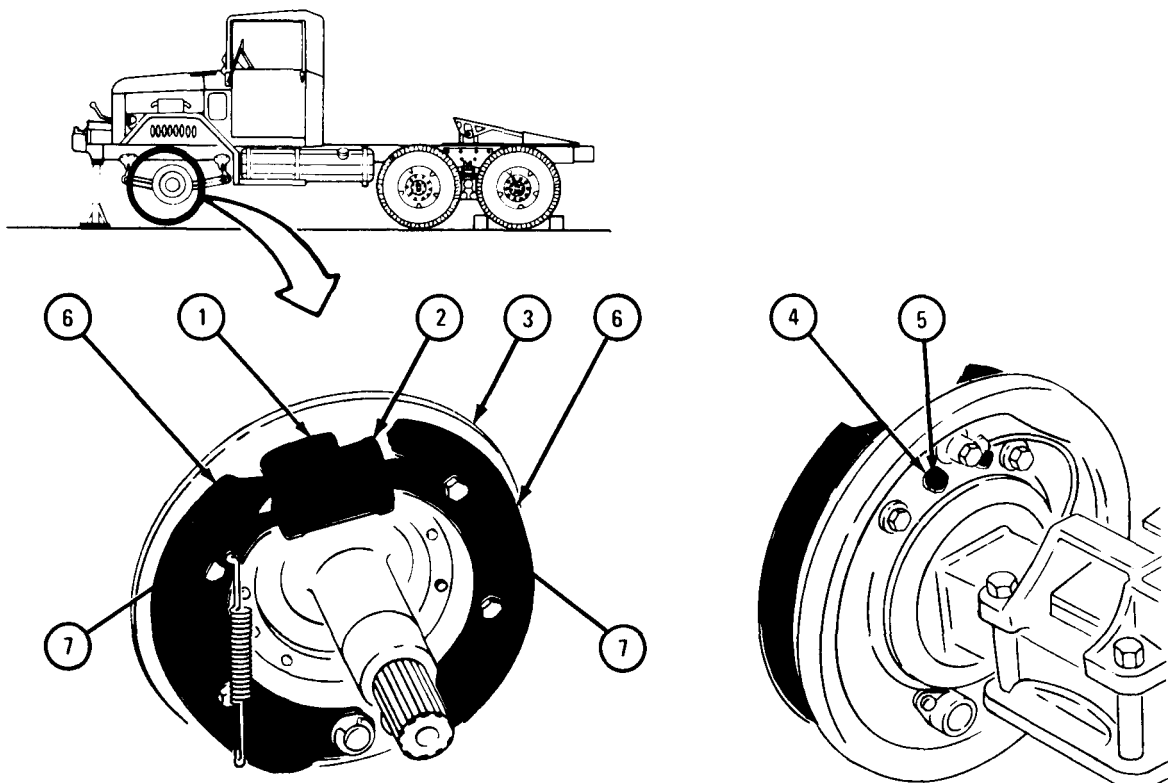

TA 046286

FRAME 2

1. Using return spring pliers (1), hook return spring end (2) in hole near guide pin (3).

GO TO FRAME 3

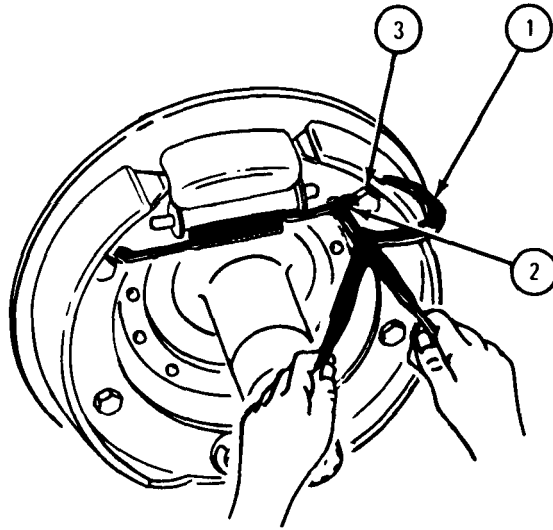

TA 046143

FRAME 3

1. Using 7/16-inch wrench, loosen screw (1) just enough so that fluid line connector (2) can be turned.
2. Turn fluid connector (2) so that screw hole in bottom lines up with hydraulic line fitting (3).
3. By hand, screw hydraulic line fitting (3) into fluid line connector (2).
4. Using 7/16-inch wrench, tighten screw (1).
5. Using 7/16-inch wrench, tighten hydraulic line fitting (3).

NOTE

Follow-on Maintenance Action Required:

1. Replace hub and brake drum assembly. Refer to para 14-4.
2. Bleed wheel cylinder. Refer to para 13-15 and 13-16.

END OF TASK

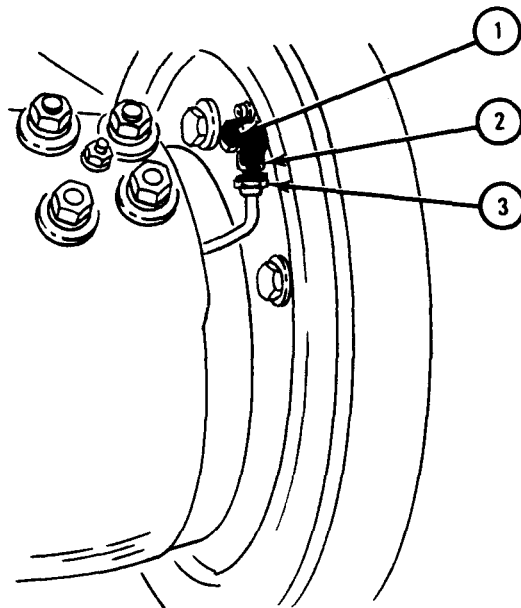

TA 046287

13-12. HYDRAULIC MASTER CYLINDER ASSEMBLY REMOVAL AND REPLACEMENT.

- | | | |
|--------|--------------------------|---------------------------------------|
| TOOLS: | 3/8-inch wrench | 3/4-inch wrench |
| | 1/2-inch wrench | Cross-tip screwdriver (Phillips type) |
| | 8-inch slip joint pliers | 1/2-gallon container |
| | 9/16-inch socket | Pliers |
| | 3/8-inch drive socket | |
| | wrench set | |

SUPPLIES: Cotter pin

PERSONNEL: One

EQUIPMENT CONDITION: Truck parked, engine off, handbrake set.

a. Removal.

FRAME 1

1. Using screwdriver, unscrew and take out screw (1). Open master cylinder access door (2).

GO TO FRAME 2

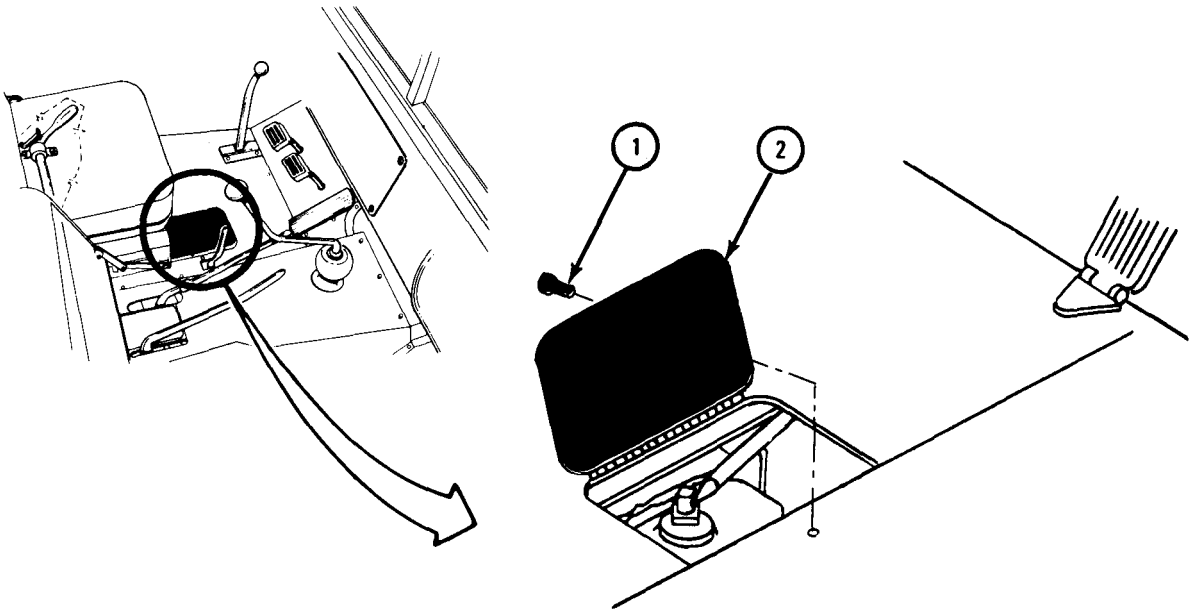

TA 051601

FRAME 2

1. Place 1/2-gallon container under master cylinder assembly (1) to catch any hydraulic fluid which may drain from hydraulic oil lines. Leave container in place until master cylinder is removed.
2. Working through opening (2) using 3/8-inch wrench, loosen tube nut (3).
3. Working through master cylinder access doorway, reach in and unscrew tube nut (3). Take off hydraulic tube (4) from master cylinder (1).

GO TO FRAME 3

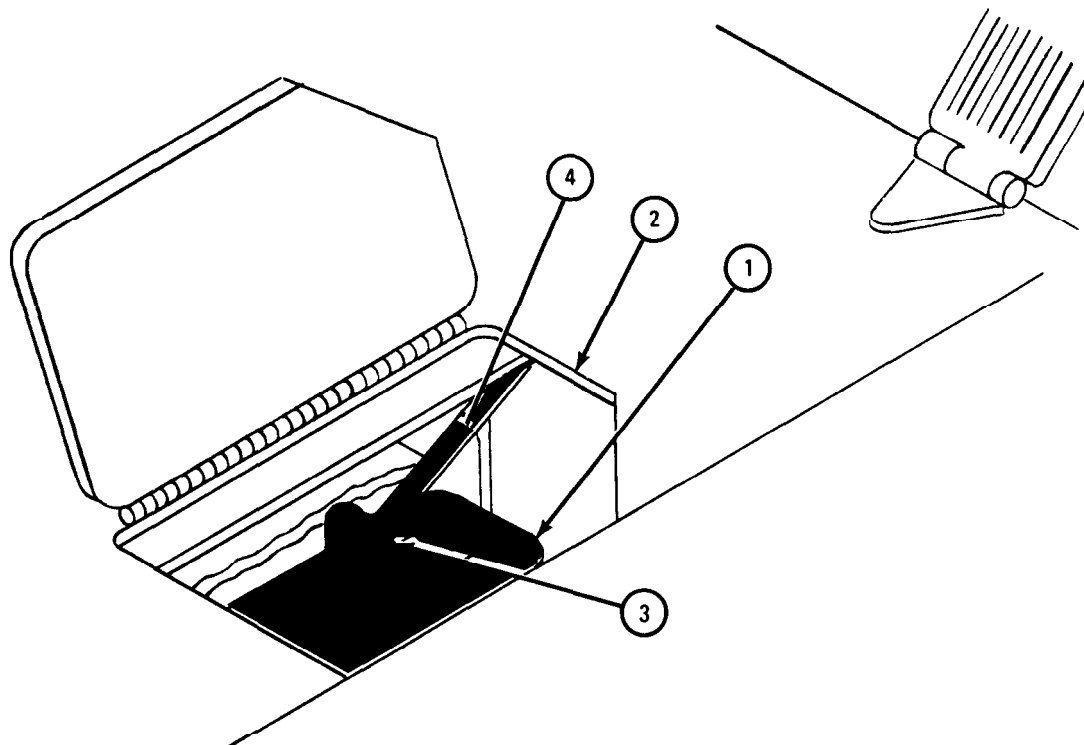

TA 051602

FRAME 3

1. Using 1/2-inch and 3/4-inch wrenches, hold tube fitting (1) and unscrew and take off tube nut (2).
2. Using 1/2-inch wrench, loosen tube nut (3) and pull away hydraulic tube (4).

GO TO FRAME 4

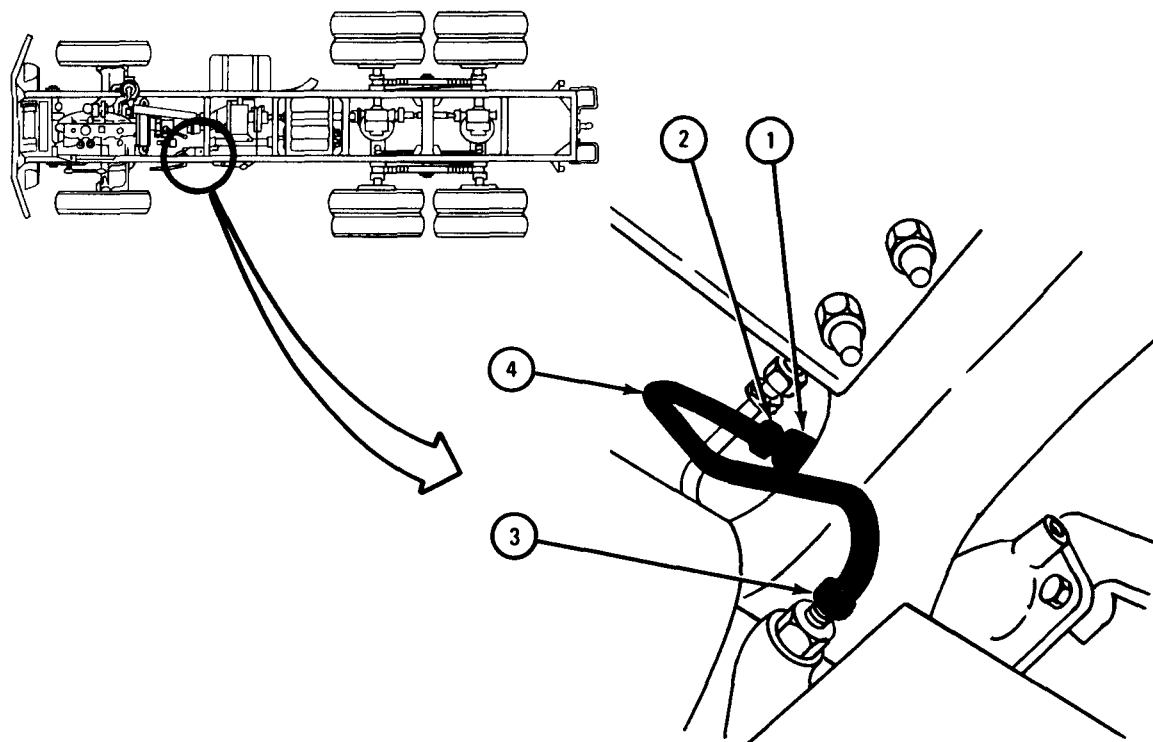

TA 051603

FRAME 4

NOTE

If truck has power takeoff, do all steps. If truck does not have power takeoff, go to step 3.

1. Using 5/8-inch socket wrench, unscrew and take out two capscrews (1).
2. Push power takeoff shift lever bracket (2) away from master cylinder assembly (3).
3. Using pliers, unhook brake pedal return spring (4) from hole in clevis pin (5).
4. Using pliers, take out and throw away cotter pin (6).
5. Using pliers, pull out clevis pin (5).

GO TO FRAME 5

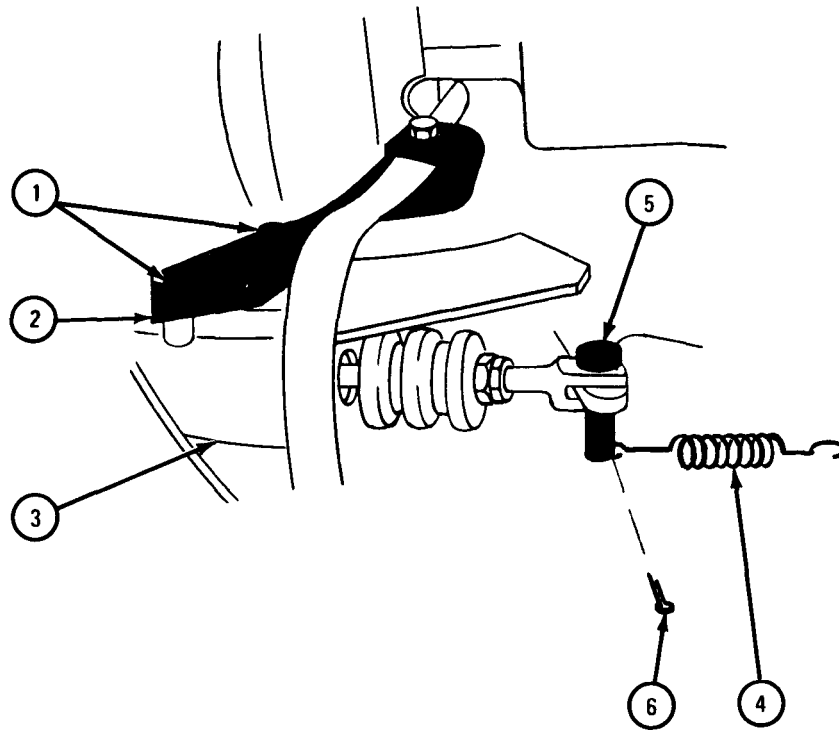

TA 051604

FRAME 5

1. Using 3/4-inch wrench, unscrew and takeout plug (1).
2. Using 9/16-inch socket wrench and 6-inch extension through access hole (2) as shown, unscrew and take out capscrew and lockwasher (3).
3. Using 9/16-inch wrench, unscrew and take out three capscrews and lockwashers (4).
4. Lift front of master cylinder assembly (5) up and back into frame (6) and pull down to take it out.

END OF TASK

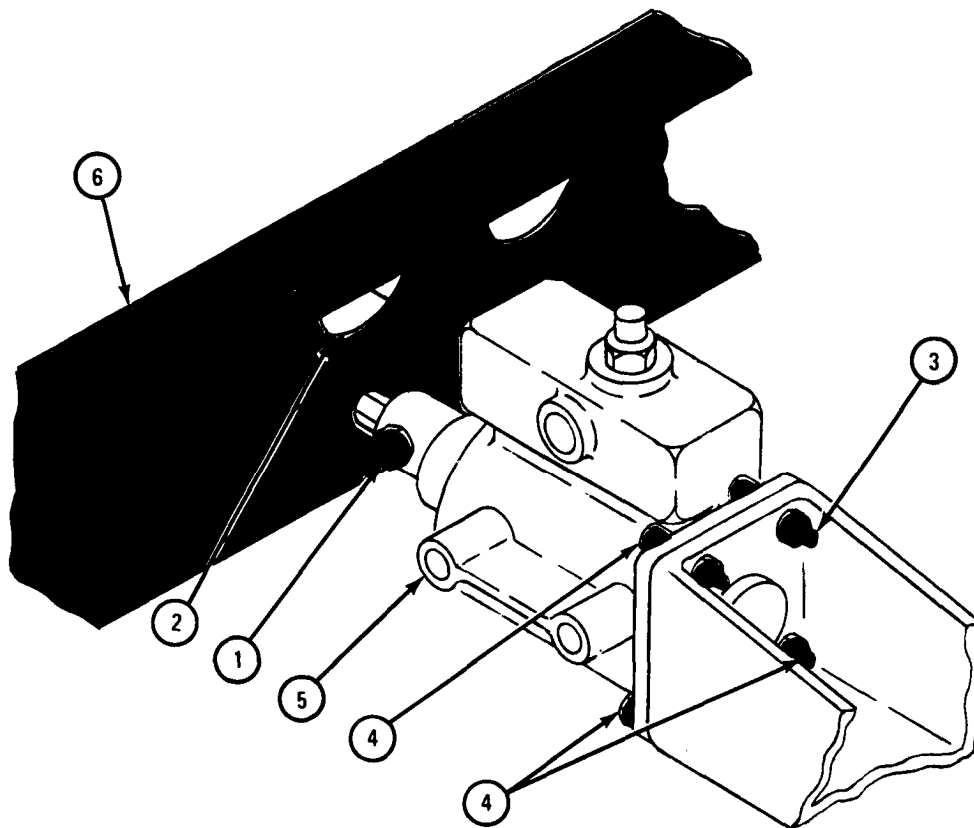

TA 051605

b. Replacement.

FRAME 1

1. Put master cylinder assembly (1) in support bracket (2) and aline holes.
2. Screw in three capscrews and washers (3).
3. Reach over top of master cylinder (1) and screw in capscrew and lockwasher (4).
4. Using 9/16-inch socket wrench, with 6-inch extension through access hole (5) as shown, tighten capscrew and lockwasher (4).
5. Using 9/16-inch wrench, tighten three capscrews and lockwashers (3).
6. Using 3/4-inch wrench, screw in and tighten plug (6).

GO TO FRAME 2

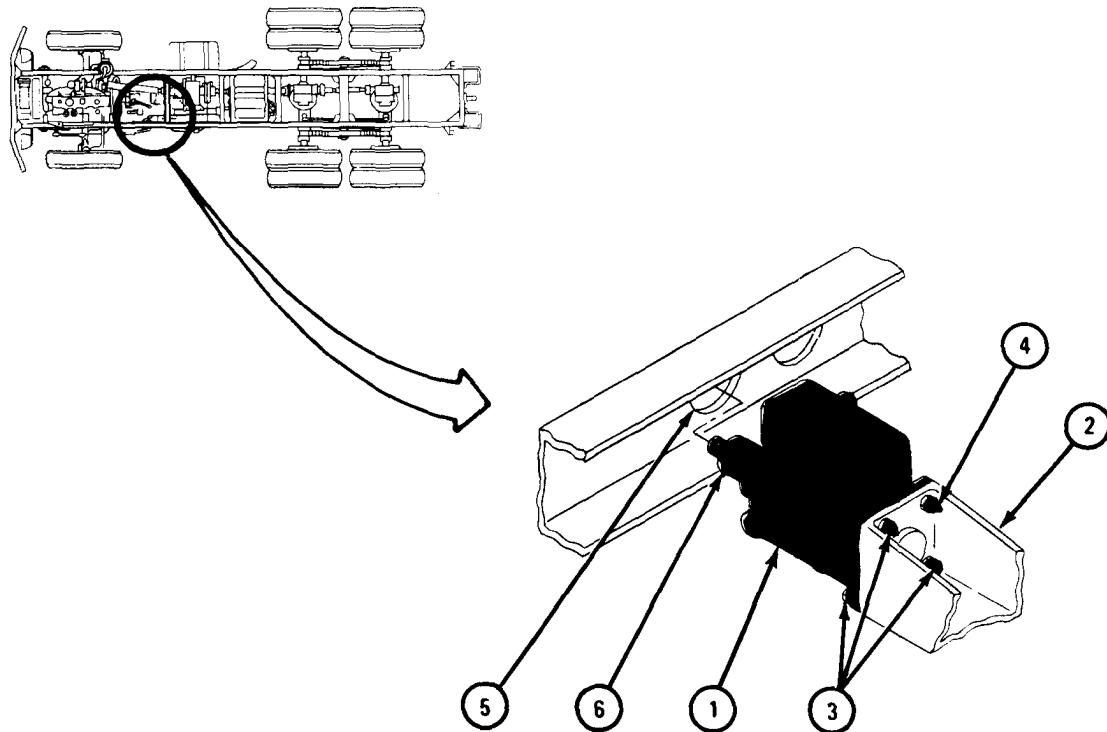

TA 051606

FRAME 2

NOTE

If truck has power takeoff, do all steps. If truck does not have power takeoff, do steps 1 through 5 only.

1. Push clevis assembly (1) into back of master cylinder assembly (2) as far as it will go.
2. Put brake pedal lever (3) in clevis assembly (1).
3. Put in clevis pin (4).
4. Using pliers, put in cotter pin (5) and bend open ends of cotter pin.
5. Using pliers, hook brake pedal return spring (6) in hole at end of clevis pin (4).
6. Put power takeoff shift lever bracket (7) on master cylinder assembly (2) and align holes.
7. Using 5/8-inch socket wrench, screw in and tighten two screws (8).

GO TO FRAME 3

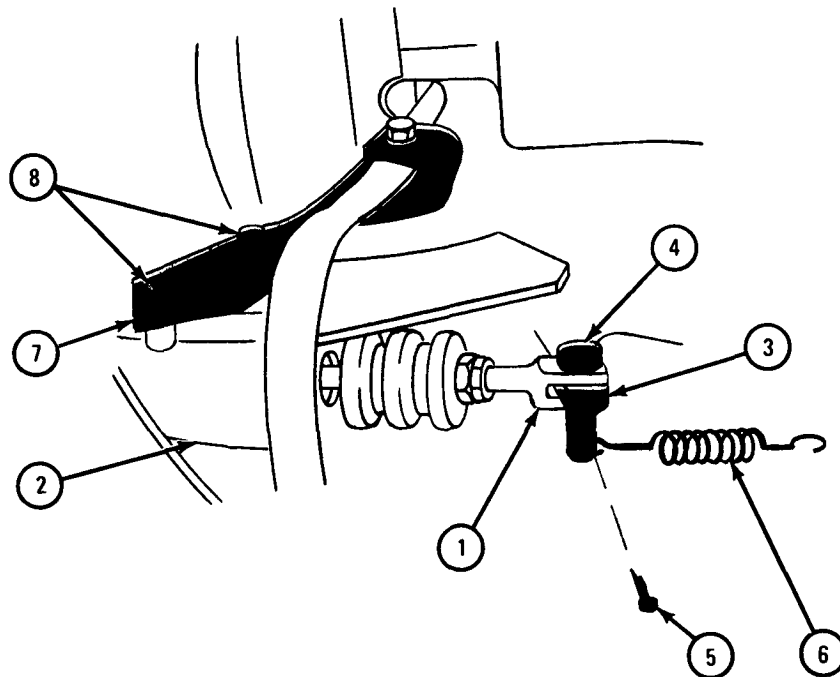

TA 051607

FRAME 3

1. Put hydraulic tube (1) on front of master cylinder assembly (2).
2. Using 1/2-inch wrench, screw in and tighten tube nut (3).
3. Using 1/2-inch wrench, tighten tube nut (4).

GO TO FRAME 4

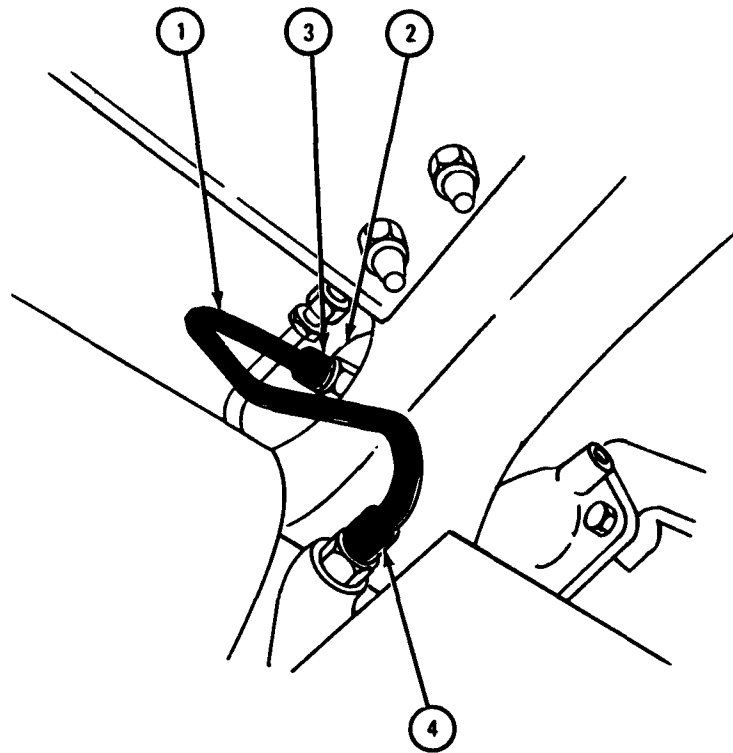

TA 051608

FRAME 4

1. Through master cylinder access doorway (1), join hydraulic tube (2) to tube fitting (3) and screw in tube nut (4).
2. Using 3/8-inch wrench, tighten tube nut (4) through doorway (1).
3. Close master cylinder access door (5).
4. Using screwdriver, screw in and tighten screw (6).

NOTE

Follow-on Maintenance Action Required:

Bleed hydraulic brake system. Refer to para 13-15 and 13-16.

END OF TASK

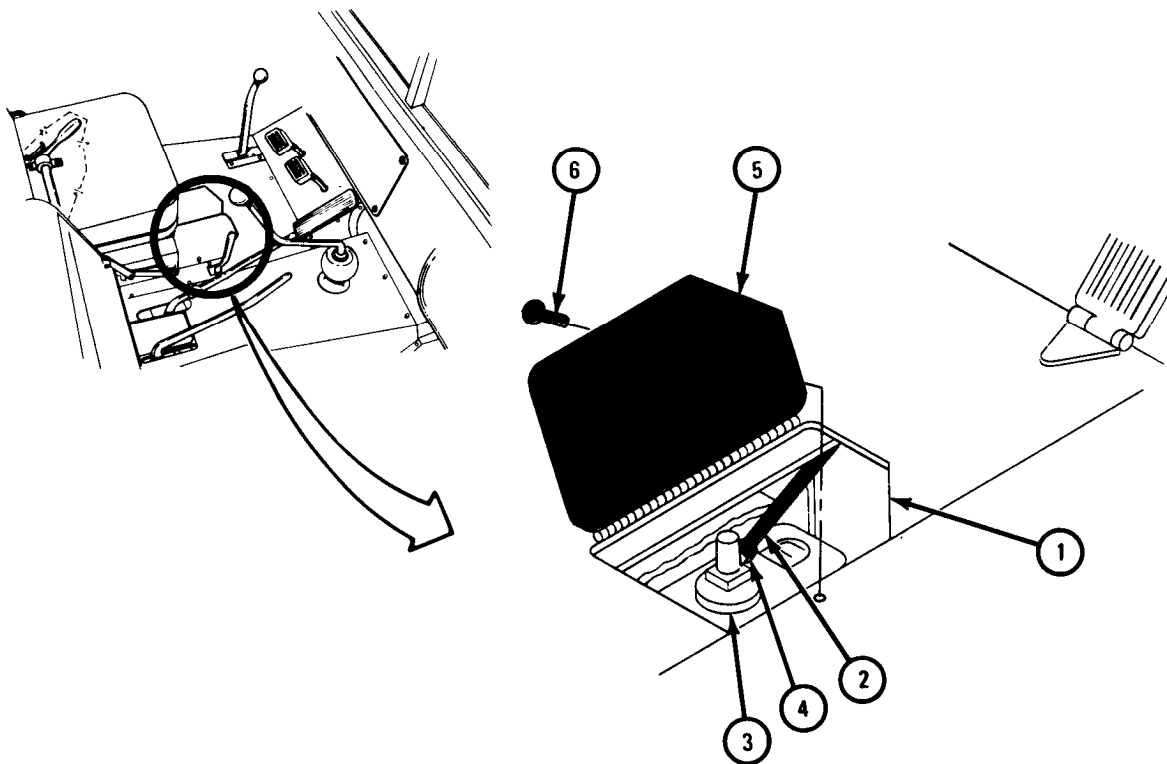

TA 051609

13-13. HYDRAULIC LINES, HOSES, AND FITTINGS REMOVAL AND REPLACEMENT.

NOTE

Procedures given are typical and cover all the different types of installations that you will find on the trucks. Refer to system schematic illustrations used as support diagrams for troubleshooting each system (vol. 2, chapter 12, Fig. 46-1).

<p>TOOLS: 6-inch pliers Cutting pliers 9/16-inch open end wrench 7/16-inch open end wrench 1-gallon container 7/16-inch combination box and open end box wrench 5/8-inch combination box and open end box wrench</p>	<p>Cross-tip screwdriver (Phillips type) 15/16-inch open end wrench 5/8-inch wrench 3/4-inch open end wrench 7/8-inch open end wrench 1/2-inch open end wrench 13/16-inch combination box and open end box wrench</p>
--	---

SUPPLIES: Caps
Tags
Plastic ties

PERSONNEL: One

EQUIPMENT CONDITION: Truck parked, engine off, handbrake set.

a. Removal.

NOTE

Put container under hydraulic lines and fittings to catch draining hydraulic fluid. Cap all open hoses, lines, and fittings to keep dirt from getting into hydraulic systems.

Tag all lines so that they will be put back in the same place. Some hydraulic lines and hoses may have plastic ties in place of clamps. If so, cut and take off all plastic ties.

(1) Hydraulic lines and clamps.

NOTE

Hydraulic line on left rear axle is used for this typical procedure.

FRAME 1

1. Using 9/16-inch wrench, hold multiple connector (1). Using 7/16-inch combination box and open end wrench, unscrew and take out tube nut (2).

GO TO FRAME 2

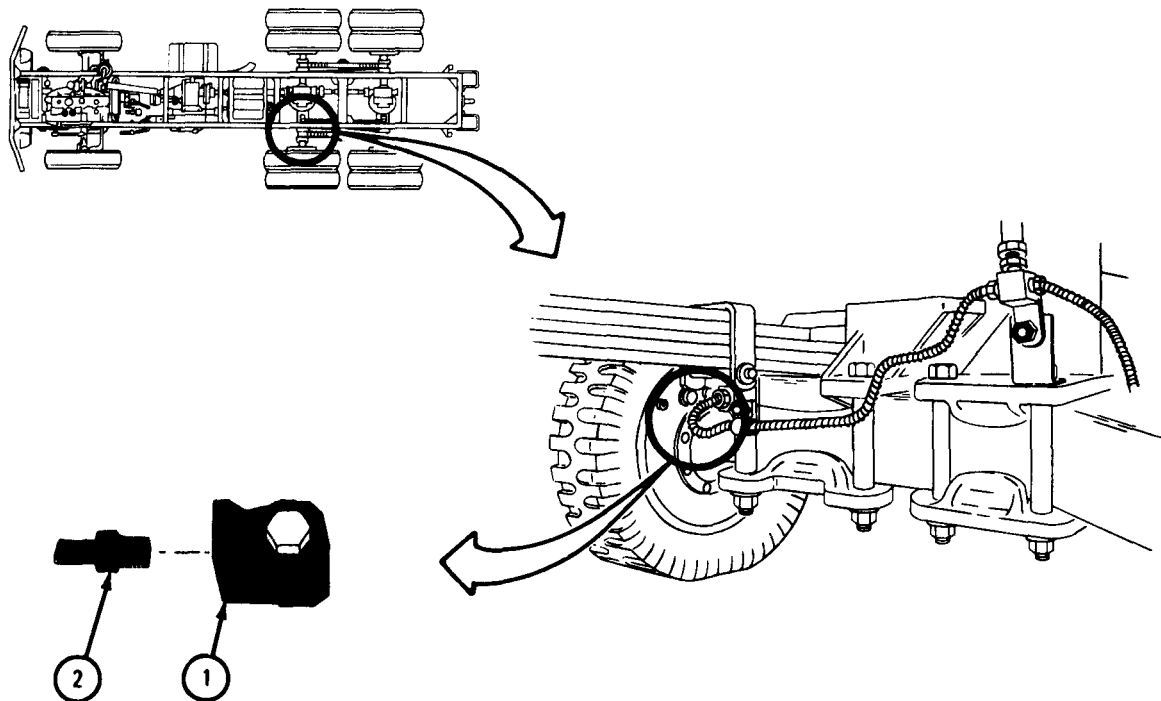

TA 087002

FRAME 2

1. Using $7/8$ -inch wrench, hold multiple tee fitting (1). Using $7/16$ -inch combination box and open end box wrench, unscrew and take out tube nut (2).
GO TO FRAME 3

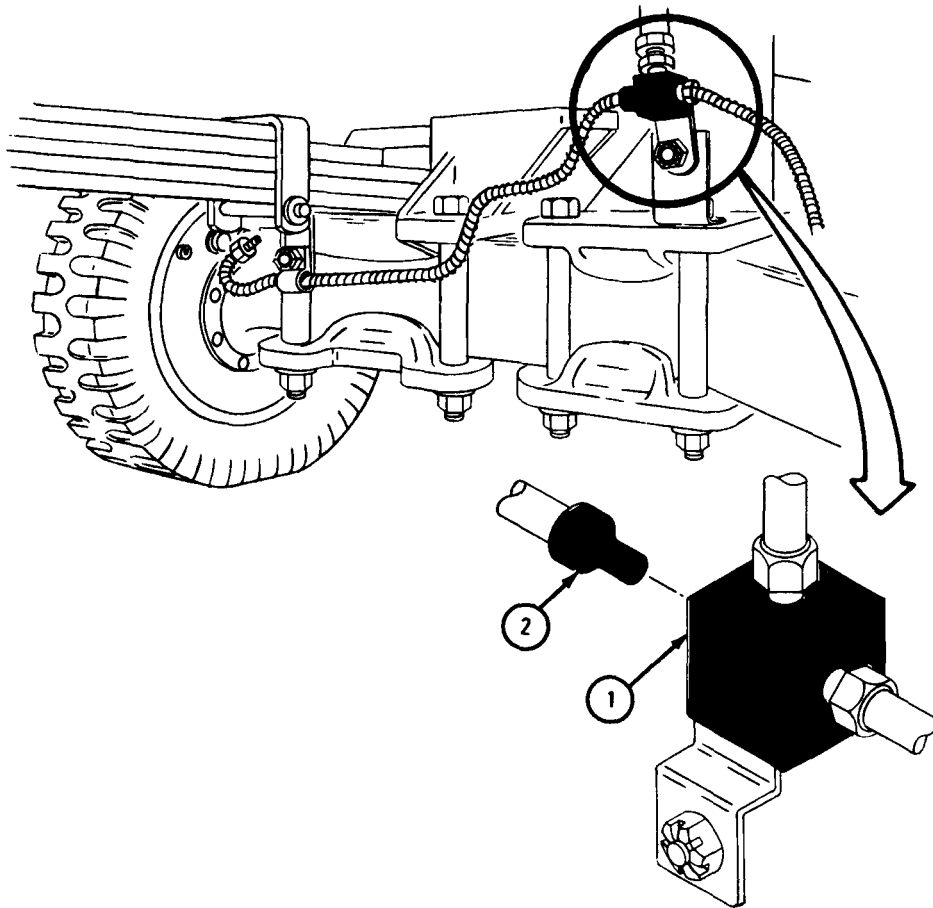

TA 101648

FRAME 3

1. Using 9/16-inch open end wrench, hold self-locking nut (1). Using 9/16-inch open end wrench, unscrew and take off capscrew (2).
2. Spread open and take off clamp (3).

END OF TASK

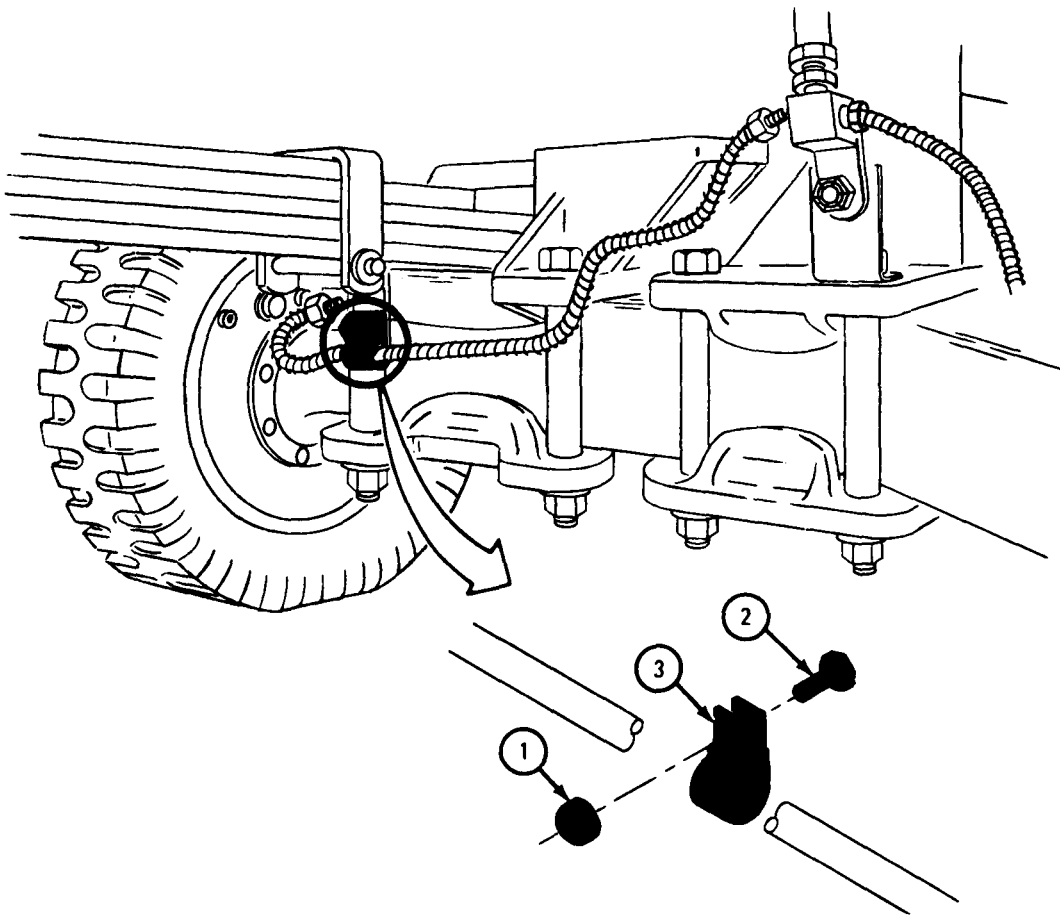

TA 087010

(2) Hydraulic hose.

NOTE

Hydraulic hose on left front axle is used for this typical procedure.

FRAME 1

1. Using 5/8-inch combination box and open end box wrench, hold tube nut (1). Using 7/16-inch combination box and open end box wrench, unscrew and take off tube nut (2).
2. Using 5/8-inch combination box and open end box wrench, hold tube nut (1). Using 15/16-inch open end wrench, unscrew and take off nut (3) and washer (4).

GO TO FRAME 2

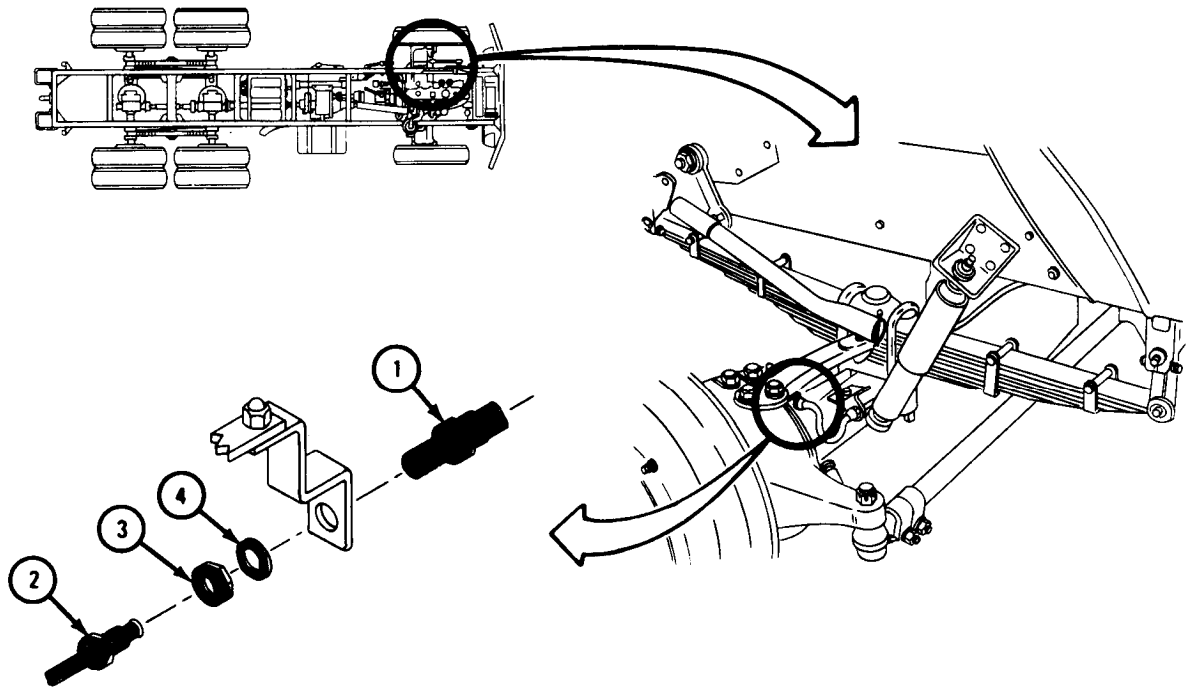

TA 087004

FRAME 2

1. Using 5/8-inch combination box and open end box wrench, hold tube nut (1). Using 7/16-inch combination box and open end box wrench, unscrew and take off tube nut (2).
2. Using 5/8-inch combination box and open end box wrench, hold tube nut (1). Using 15/16-inch open end wrench, unscrew and take off nut (3) and washer (4).
3. Take out tube nut (1).

END OF TASK

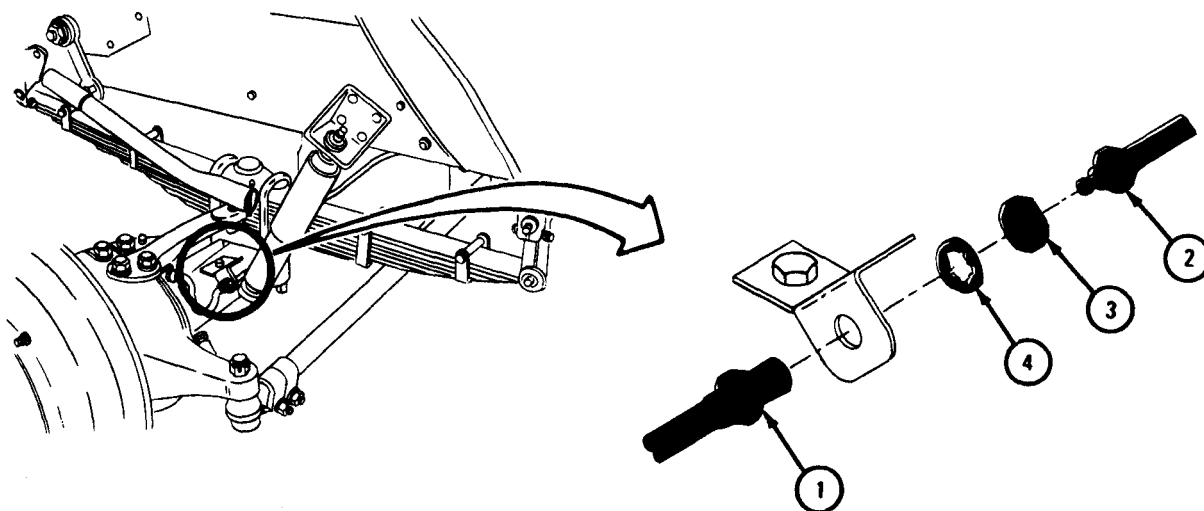

TA 087005

(3) Fittings.

(a) Tube and elbow assembly

NOTE

Tube and elbow assembly on air hydraulic cylinder is used for this typical procedure.

FRAME 1

1. Using 5/8-inch wrench, unscrew and take out two screws (1). Take off skid plate (2).

GO TO FRAME 2

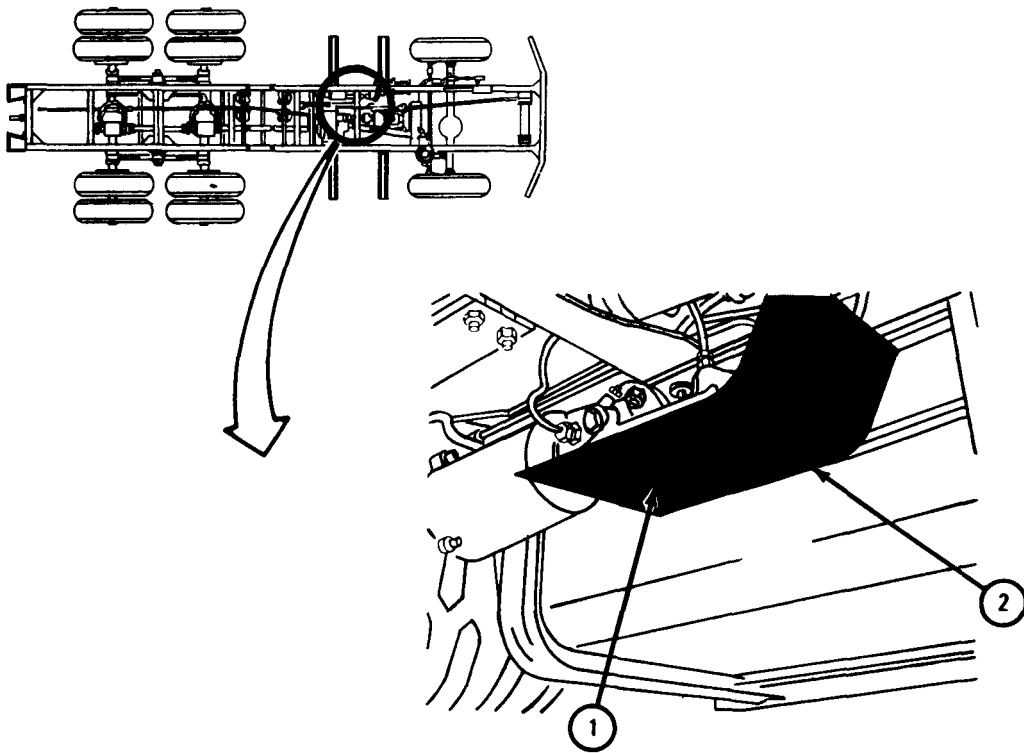

TA 046621

FRAME 2

1. Using 5/8-inch open end wrench, hold elbow (1). Using 13/16-inch combination box and open end box wrench, unscrew and take off tube nut (2).
2. Using 5/8-inch open end wrench, unscrew and take off elbow (1).

END OF TASK

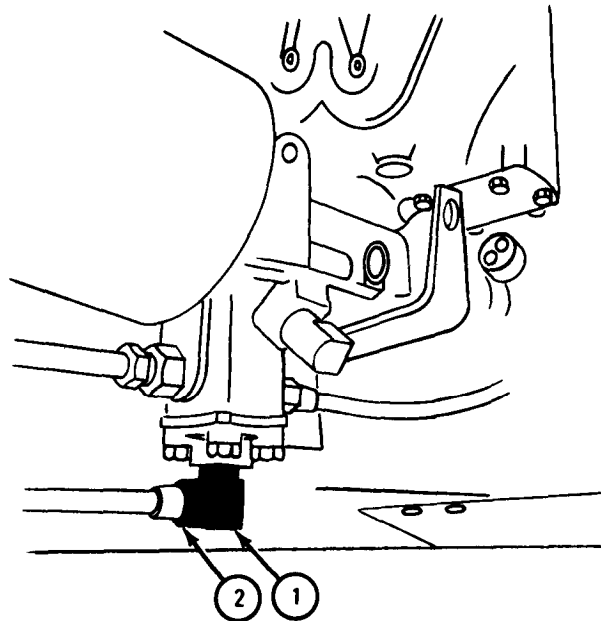

TA 105215

(b) Multiple tee fitting

NOTE

Multiple tee fitting on brake hydraulic line on left rear axle is used for this typical procedure.

FRAME 1

1. Using 7/8-inch open end wrench, hold multiple tee fitting (1). Using 1/2-inch open end wrench, unscrew and take off adapter (2).
2. Using 7/8-inch open end wrench, hold multiple tee fitting (1). Using 7/16-inch combination box and open end box wrench, unscrew and take off two tube nuts (3).
3. Using 9/16-inch open end wrench, hold self-locking nut (4). Using 9/16-inch open end wrench, unscrew and take out capscrew (5). Take off multiple tee fitting (1).

END OF TASK

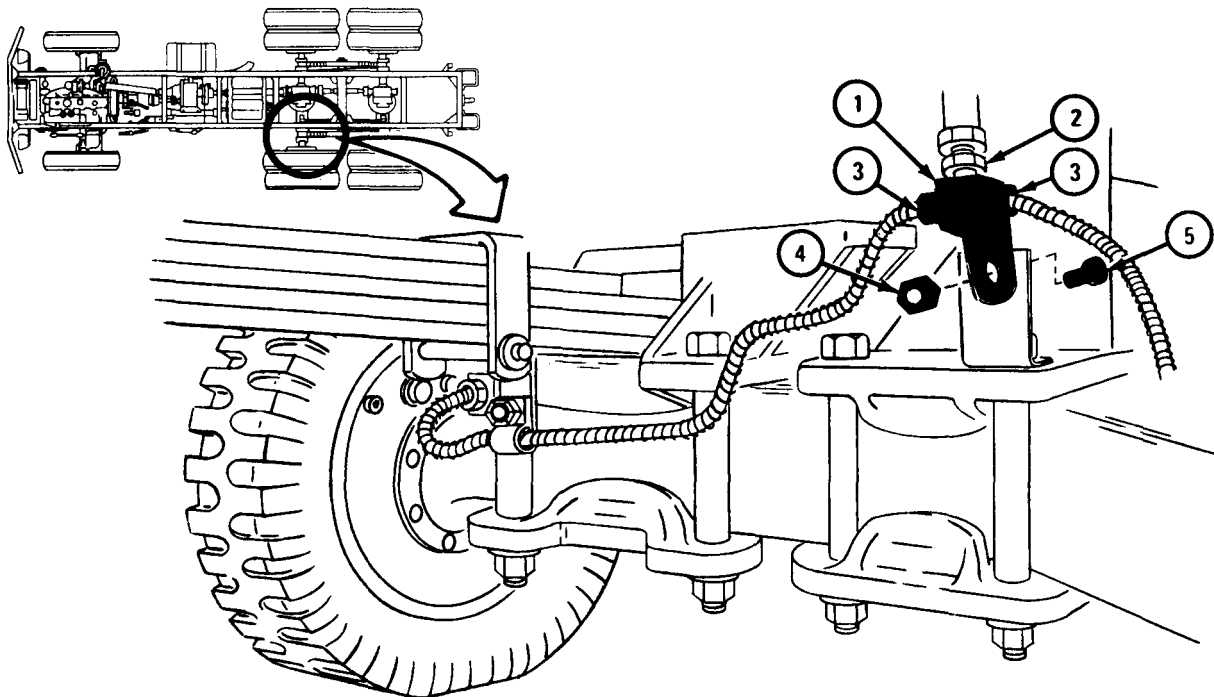

TA 087003

(c) Elbow and adapter assembly

NOTE

Elbow and adapter assembly on master cylinder is used for this typical procedure.

FRAME 1

1. Using screwdriver, unscrew screw on master cylinder hatch (1) and open hatch.
2. Using 7/16-inch open end wrench, hold elbow (2). Using 7/16-inch combination box and open end wrench, unscrew and take off tube nut (3).
3. Using 3/4-inch open end wrench, hold adapter (4). Using 7/16-inch open end wrench, unscrew and take out elbow (2).
4. Using 7/8-inch open end wrench, unscrew and take out adapter (4).

END OF TASK

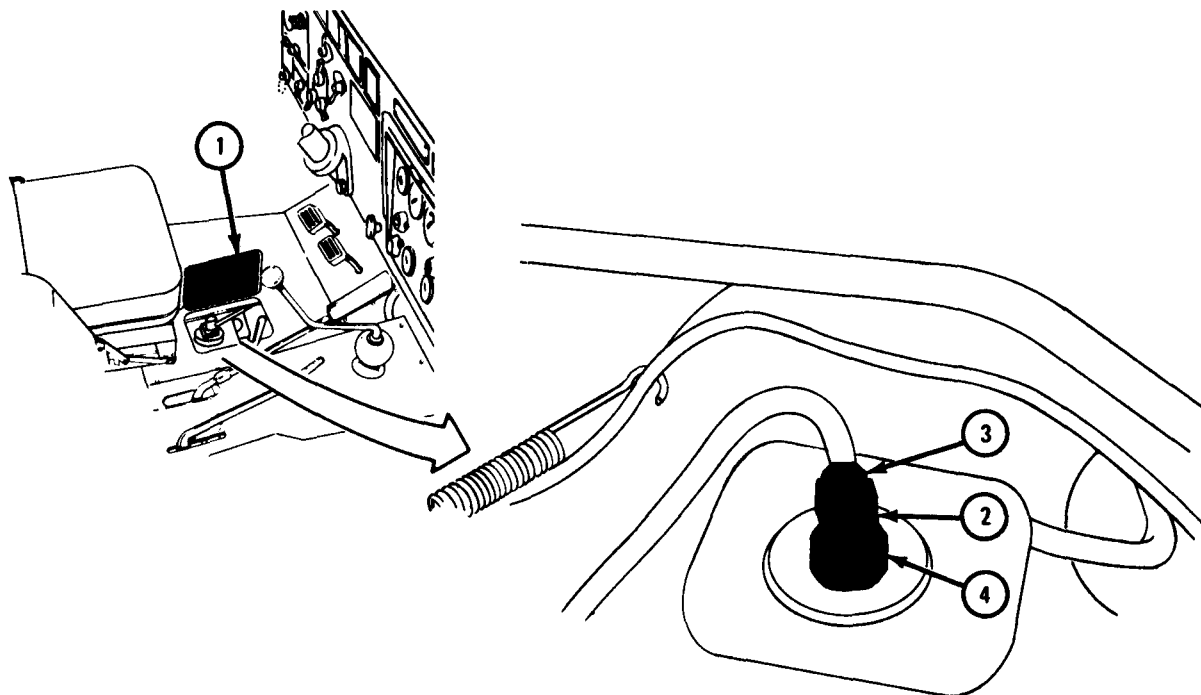

TA 087007

b. Replacement.

- (1) Hydraulic lines and clamps.

CAUTION

Fittings are made of soft brass. They can be stripped very easily if tightened too much. Tighten fittings just enough to stop fluid from leaking.

NOTE

Hydraulic brake line on left rear axle is used for this typical procedure.

FRAME 1

1. Using 9/16-inch open end wrench, hold multiple connector (1). Using 7/16-inch combination box and open end box wrench, screw in and tighten tube nut (2).

GO TO FRAME 2

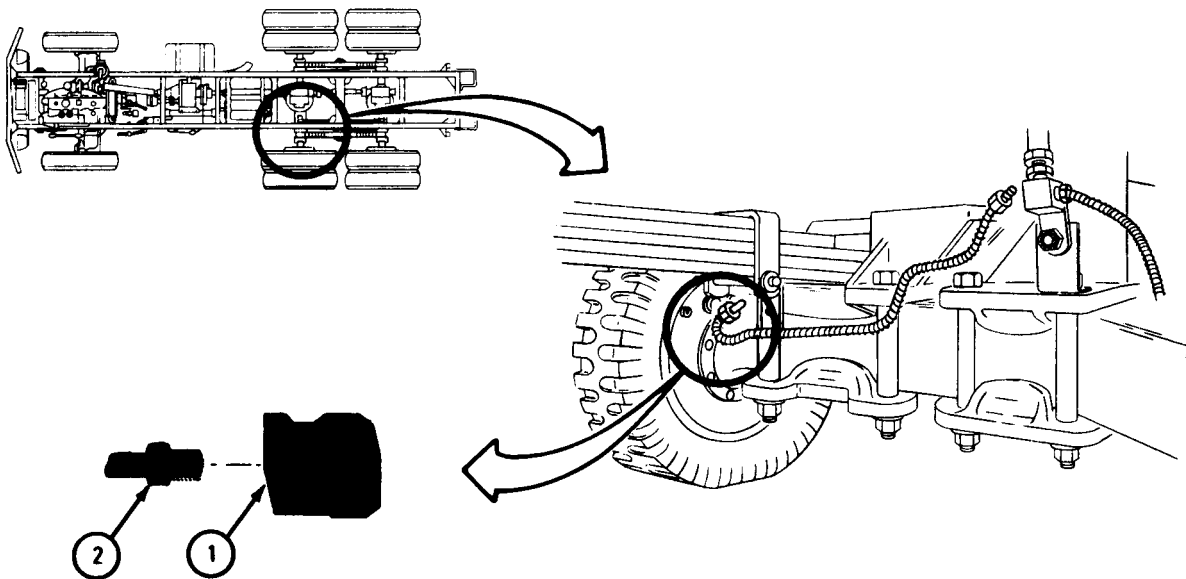

TA 087011

FRAME 2

1. Using 7/8-inch wrench, hold multiple tee fitting (1). Using 7/16-inch combination box and open end box wrench, screw in and tighten tube nut (2).

GO TO FRAME 3

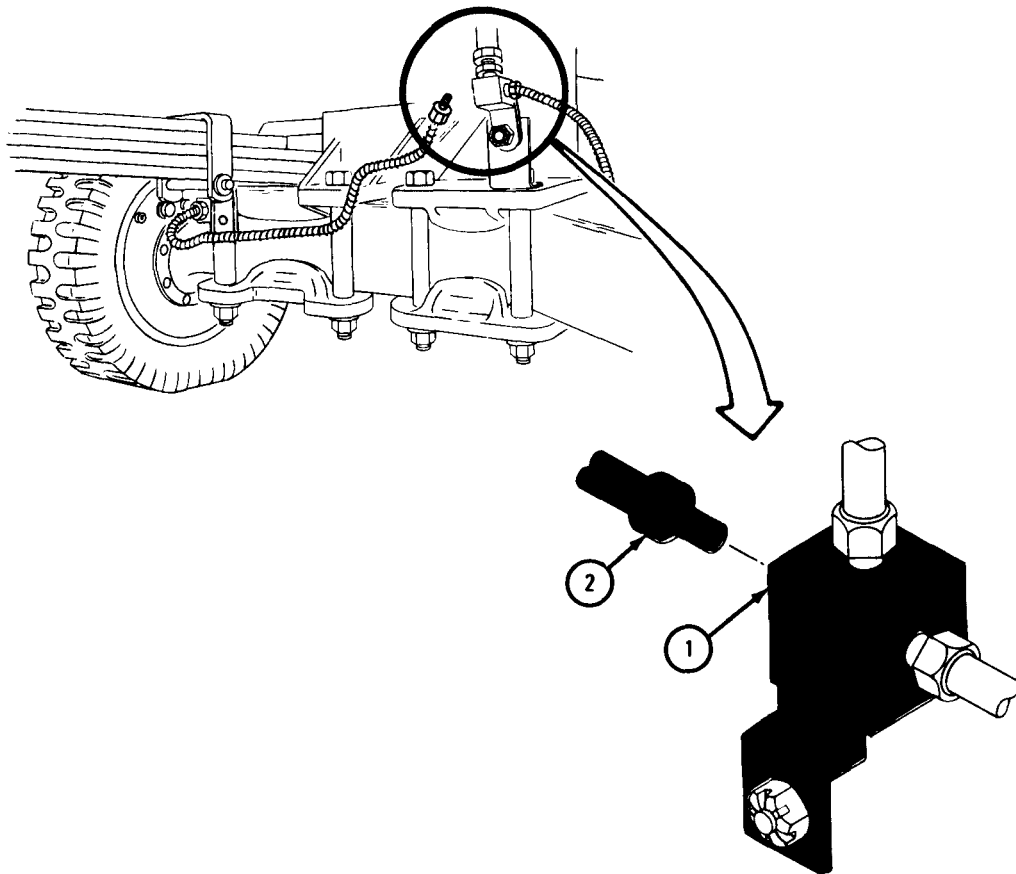

TA 101649

FRAME 3

1. Put clamp (1) on hydraulic line (2) and align screw holes.
2. Using 9/16-inch open end wrench, put in and hold cap screw (3).
3. Using 9/16-inch open end wrench, screw on and tighten self-locking nut (4).

END OF TASK

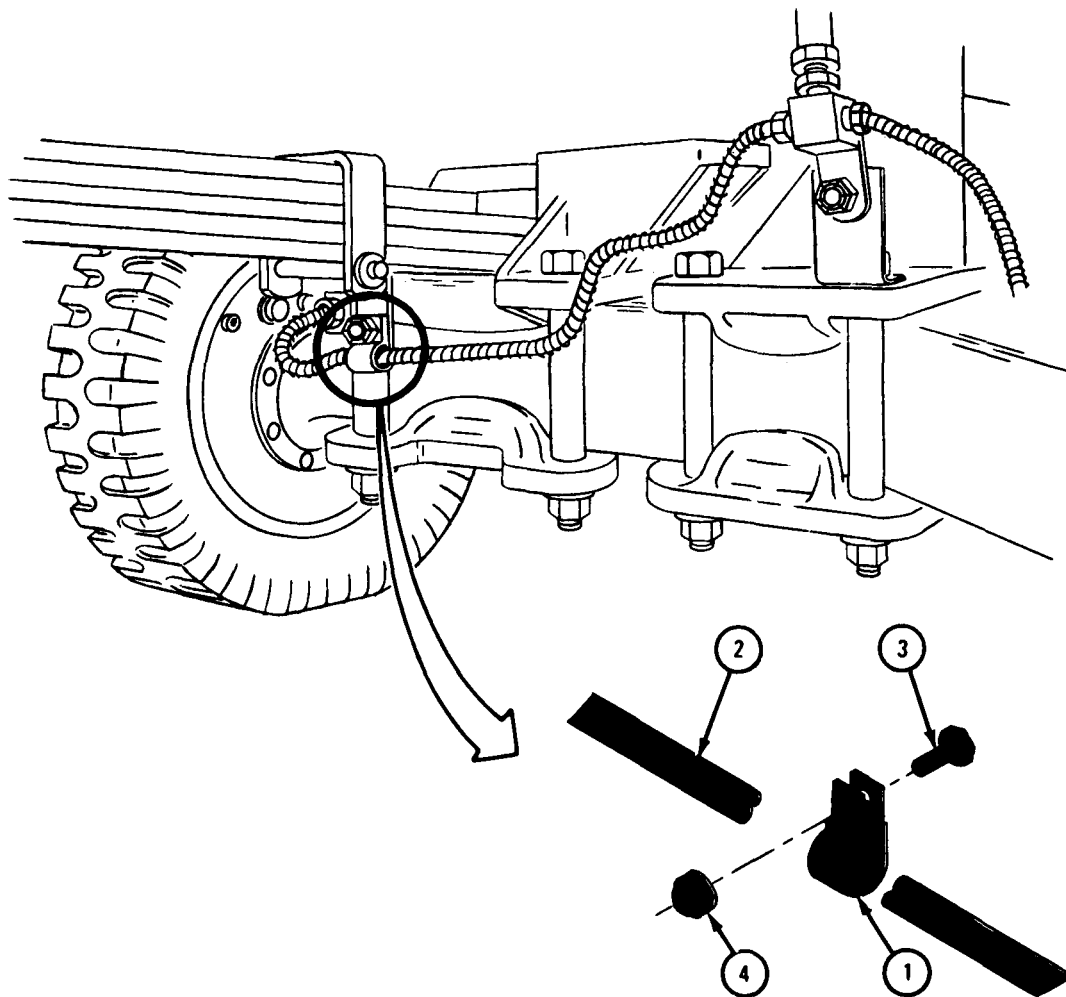

TA 087018

(2) Hydraulic hose.

CAUTION

Fittings are made of soft brass. They can be stripped very easily if tightened too much. Tighten fittings just enough to stop fluid from leaking.

NOTE

Hydraulic hose on left front axle is used for this typical procedure.

FRAME 1

1. Using 5/8-inch combination box and open end box wrench, put in and hold tube nut (1). Using 15/16-inch open end wrench, screw on and tighten washer (2) and nut (3).
2. Using 15/16-inch combination box and open end box wrench, hold tube nut (3). Using 7/16-inch combination box and open end box wrench, screw on and tighten tube nut (4).

GO TO FRAME 2

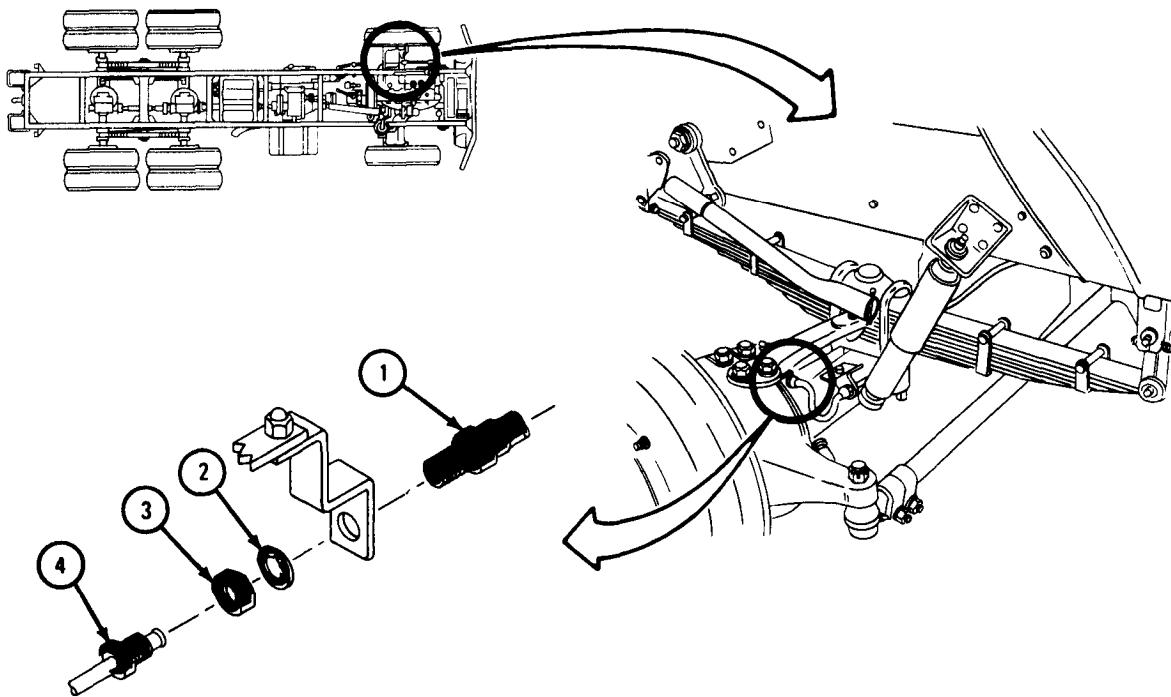

TA 087014

FRAME 2

1. Using 5/8-inch combination box and open end box wrench, put in and hold tube nut (1). Using 15/16-inch open end wrench, screw on and tighten washer (2) and nut (3).
2. Using 15/16-inch combination box and open end box wrench, hold tube nut (3). Using 7/16-inch combination box and open end box wrench, screw on and tighten tube nut (4).

NOTE

Follow-on Maintenance Action Required:

Bleed hydraulic system. Refer to para 13-15 and 13-16.

END OF TASK

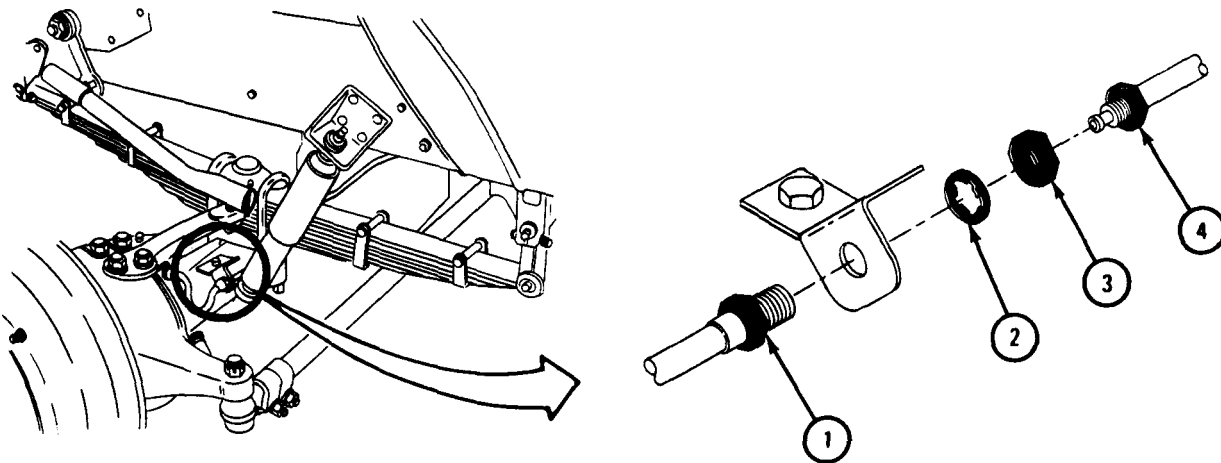

TA 087015

(3) Fittings.

(a) Tube and elbow assembly

CAUTION

Fittings are made of soft brass. They can be stripped very easily if tightened too much. Tighten fittings just enough to stop fluid from leaking.

NOTE

Tube and elbow assembly on air hydraulic cylinder is used for this typical procedure.

FRAME 1

1. Using 3/4-inch open end wrench, screw in and tighten elbow (1).
2. Using 3/4-inch open end wrench, hold elbow (1). Using 13/16-inch combination box and open end box wrench, screw on and tighten tube nut (2).

GO TO FRAME 2

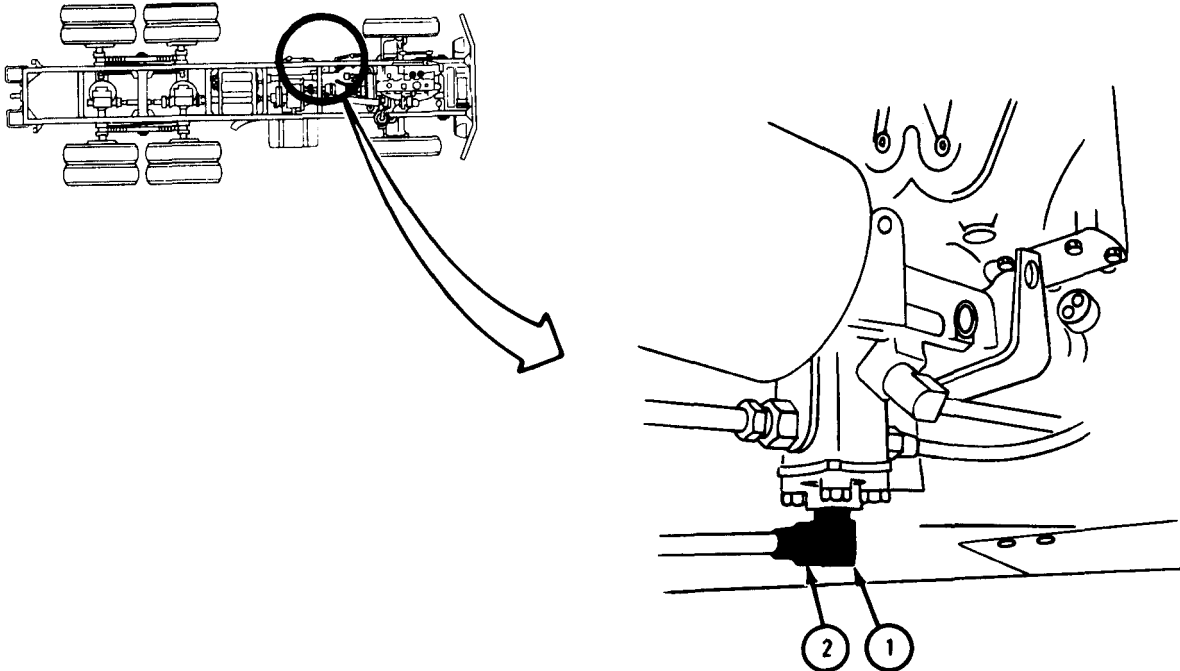

TA 087006

FRAME 2

1. Put skid plate (1) in place, alining holes.
2. Using 5/8-inch wrench, screw in and tighten two screws (2).

NOTE

Follow-on Maintenance Action Required:

Bleed hydraulic system. Refer to para 13-15 and 13-16.

END OF TASK

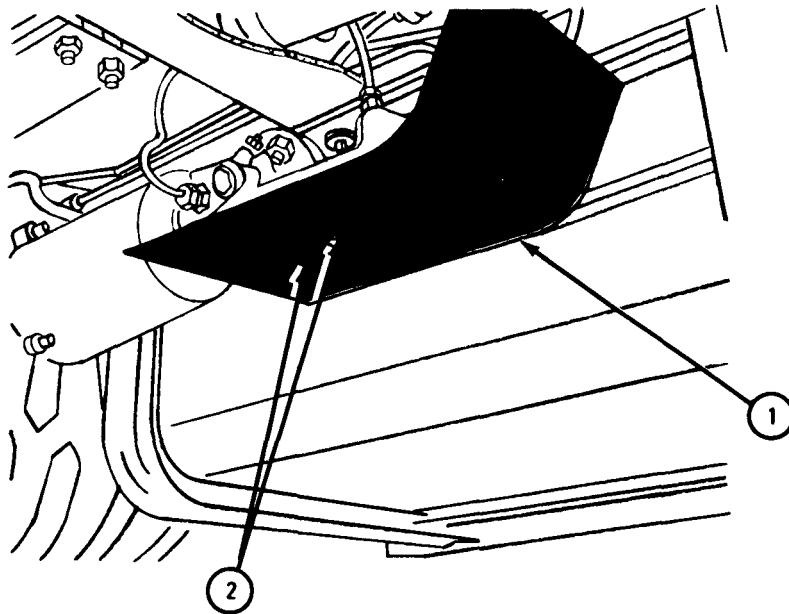

TA 046630

(b) Multiple tee fitting

CAUTION

Fittings are made of soft brass. They can be stripped very easily if tightened too much. Tighten fittings just enough to stop fluid from leaking.

NOTE

Multiple tee fitting on brake hydraulic line on the rear axle is used for this typical procedure.

FRAME 1

1. Put multiple tee fitting (1) into place and align screw holes.
2. Using 9/16-inch open end wrench, put in and hold cap screw (2). Using 9/16-inch open end wrench, screw on and tighten self-locking nut (3).
3. Using 7/8-inch open end wrench, hold multiple tee fitting (1). Using 7/16-inch combination box and open end box wrench, screw on and tighten two tube nuts (4).

GO TO FRAME 2

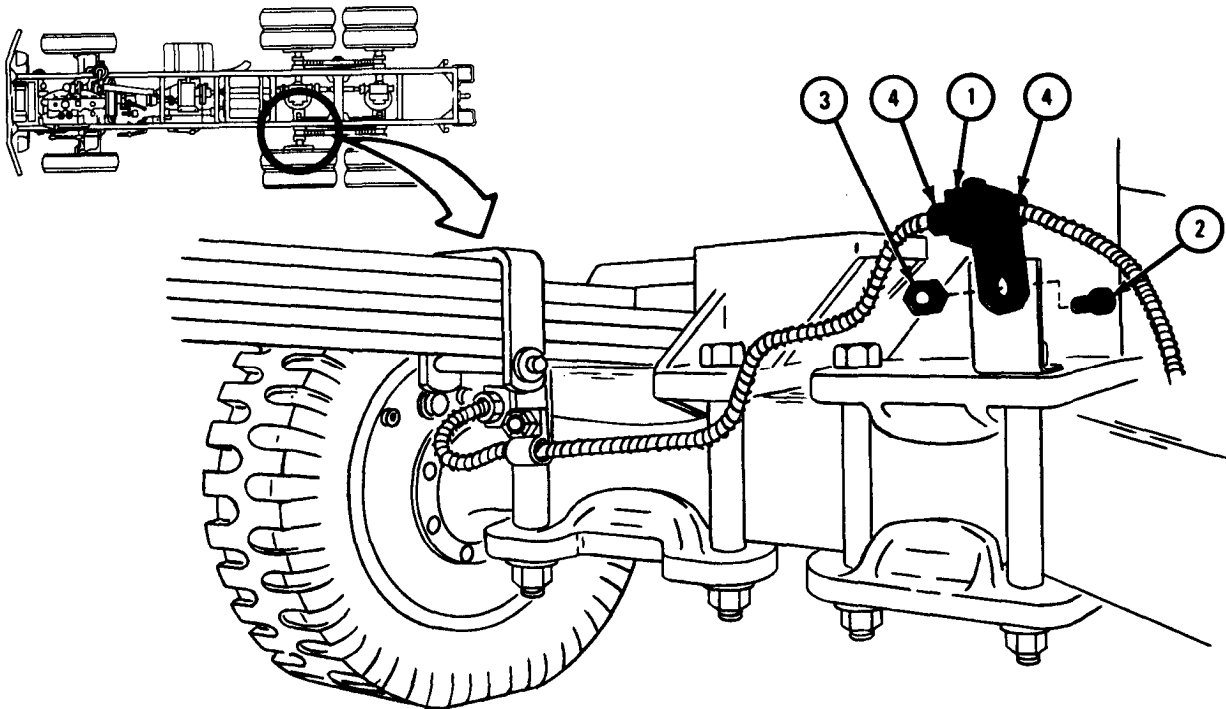

TA 087012

FRAME 2

1. Using 7/8-inch open end wrench, hold multiple tee fitting (1). Using 1/2-inch open end wrench, screw in and tighten adapter (2).

NOTE

Follow-on Maintenance Action Required:

Bleed hydraulic system. Refer to para 13-15 and 13-16.

END OF TASK

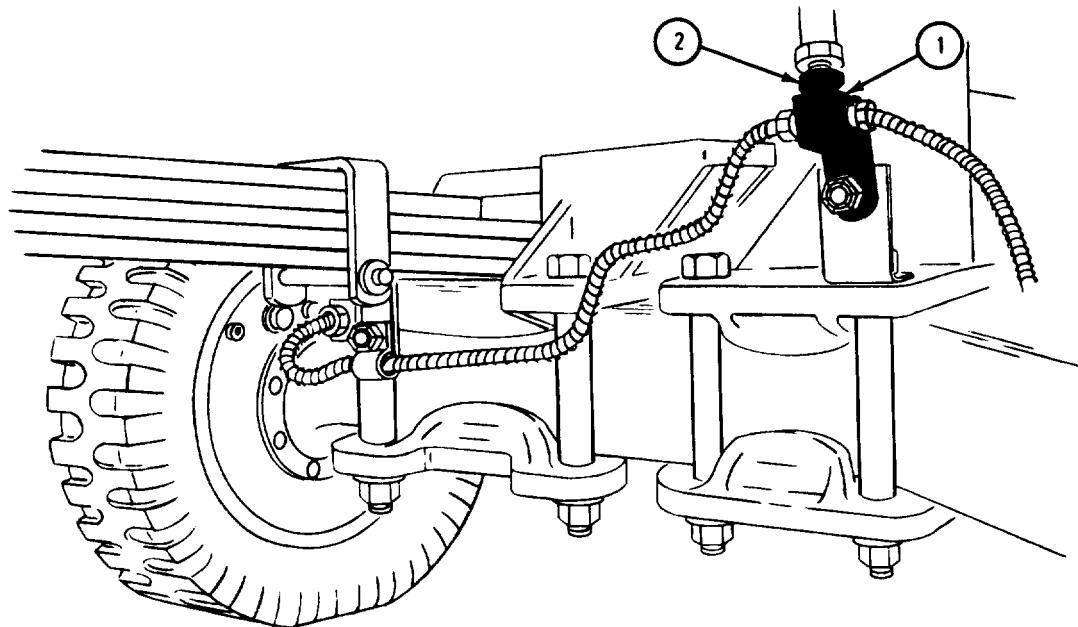

TA 087013

(c) Elbow and adapter assembly

CAUTION

Fittings are made of soft brass. They can be stripped very easily if tightened too much. Tighten fittings just enough to stop fuel from leaking.

NOTE

Elbow and adapter on the master cylinder is used for this typical procedure.

FRAME 1

1. Using 7/8-inch open end wrench, screw in and tighten adapter (1).
2. Using 7/8-inch open end wrench, hold adapter (1). Using 7/16-inch open end wrench, screw in and tighten elbow (2).
3. Using 7/16-inch open end wrench, hold elbow (2). using 3/8-inch combination box and open end wrench, screw in and tighten tube nut (3).
4. Close master cylinder hatch (4). Using screwdriver, tighten screw on hatch.

NOTE

Follow-on Maintenance Action Required:

Bleed hydraulic system. Refer to para 13-15 and 13-16.

END OF TASK

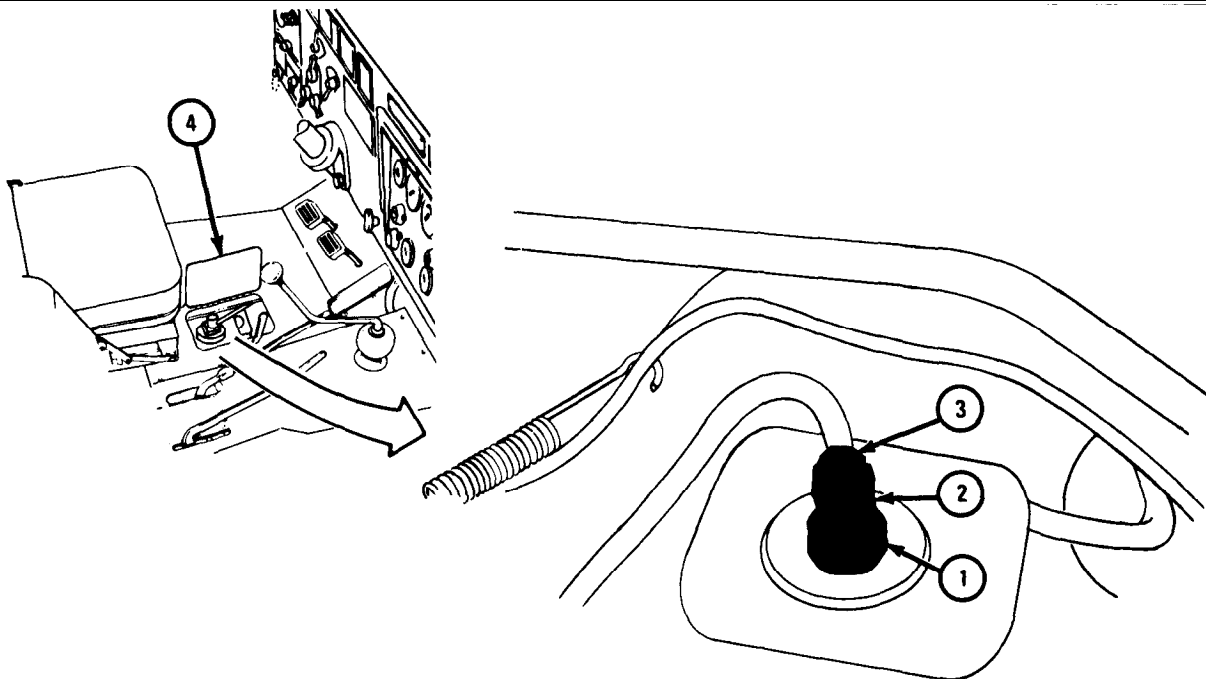

TA 102675

13-14. AIR HYDRAULIC CYLINDER REMOVAL AND REPLACEMENT.

TOOLS: 5/8-inch socket wrench
 1/2-inch open end wrench
 5/8-inch open end wrench
 1 3/16-inch combination box and open end wrench
 3/4-inch combination box and open end wrench

SUPPLIES: None

PERSONNEL: One

EQUIPMENT CONDITION: Truck parked, engine off, handbrake set.

a. Preliminary Procedure. Vent air system pressure. Refer to para 13-20.

b. Removal.

FRAME 1

1. Using 5/8-inch socket wrench, unscrew and take off two screws (1).
 2. Take off shield (2).
- GO TO FRAME 2

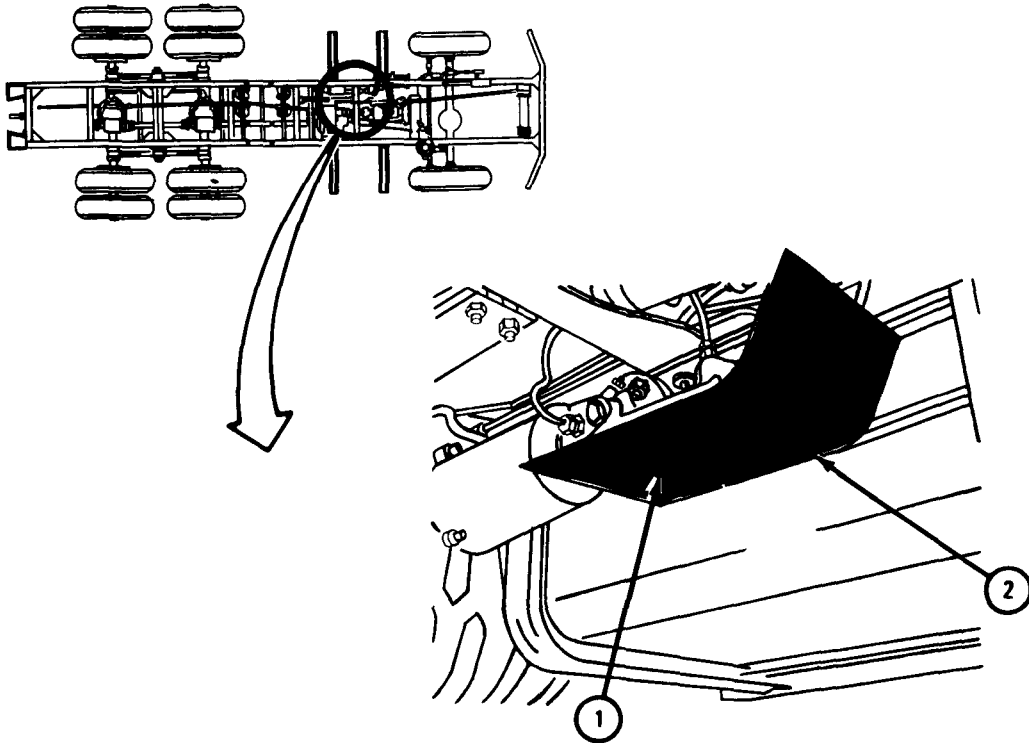

TA 046621

FRAME 2

1. Using 1/2-inch open end wrench, unscrew coupling nut (1) and take off master cylinder hydraulic line (2).
2. Using 1/2-inch open end wrench, unscrew coupling nut (3) and take off air hydraulic cylinder hydraulic line (4).
3. Using 5/8-inch open end wrench, unscrew coupling nut (5) and take off air hydraulic cylinder breather line (6).

GO TO FRAME 3

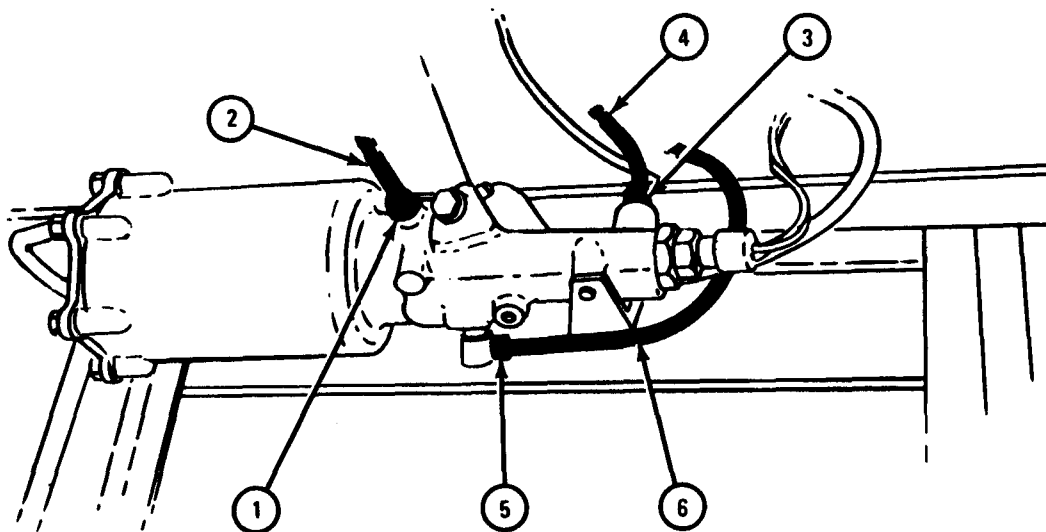

TA 046622

FRAME 3

1. Using 1 3/16-inch combination box and open end wrench, unscrew coupling nut (1) and take off air hydraulic cylinder air line (2).
2. Using 5/8-inch open end wrench, unscrew coupling nut (3) and take off trailer service air line (4).

GO TO FRAME 4

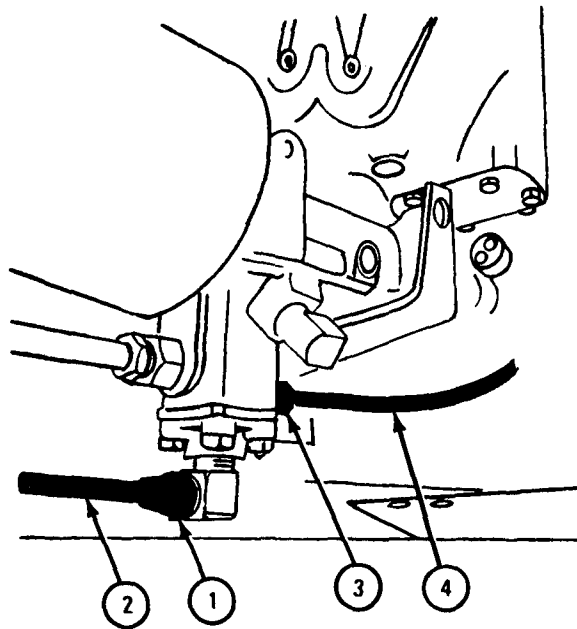

TA 046623

FRAME 4

1. Pull plug (1) out of stoplight switch connector (2).

GO TO FRAME 5

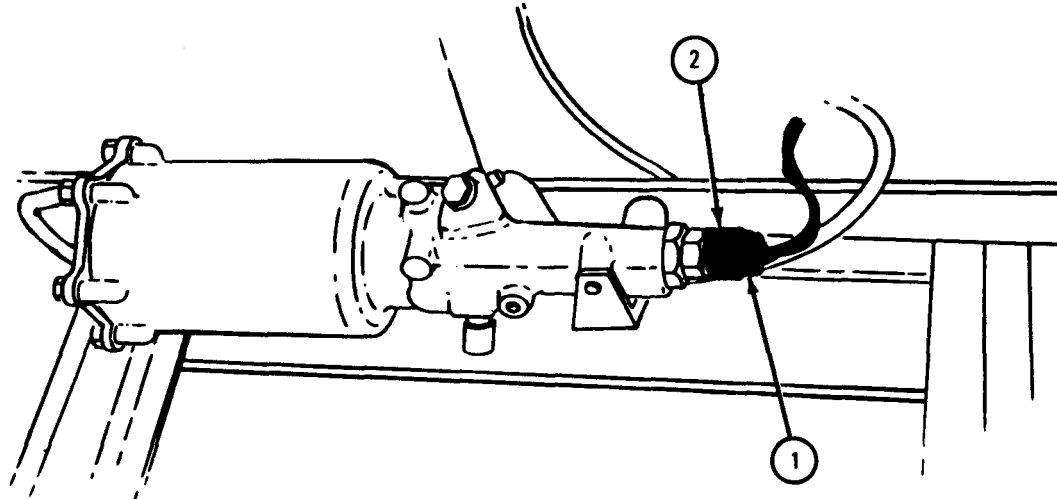

TA 046624

FRAME 5

1. Hold air hydraulic cylinder (1) with one hand.
2. Using 3/4-inch box wrench, unscrew and take out screw (2).
3. Take out air hydraulic cylinder (1).

END OF TASK

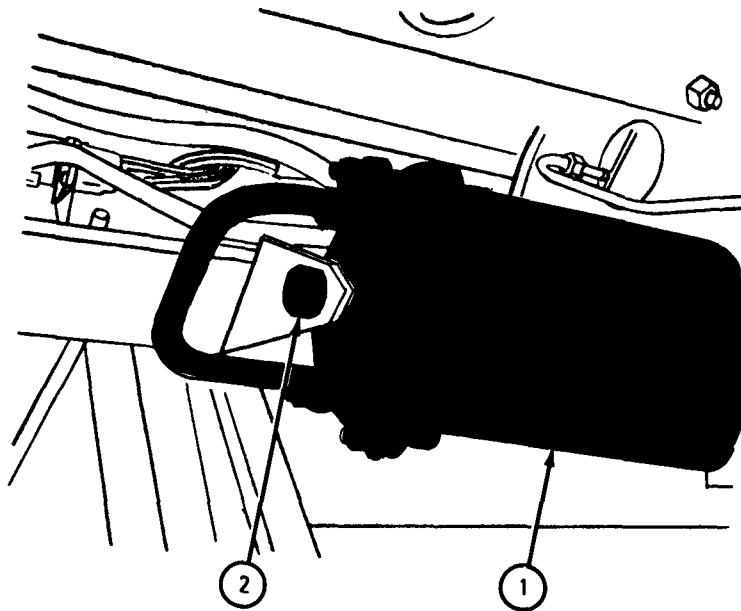

TA 046625

c. Replacement.

FRAME 1

1. Put air hydraulic cylinder (1) in place on rear mounting bracket (2).
 2. Using 3/4-inch box wrench, screw in and tighten screw (3).
- GO TO FRAME 2

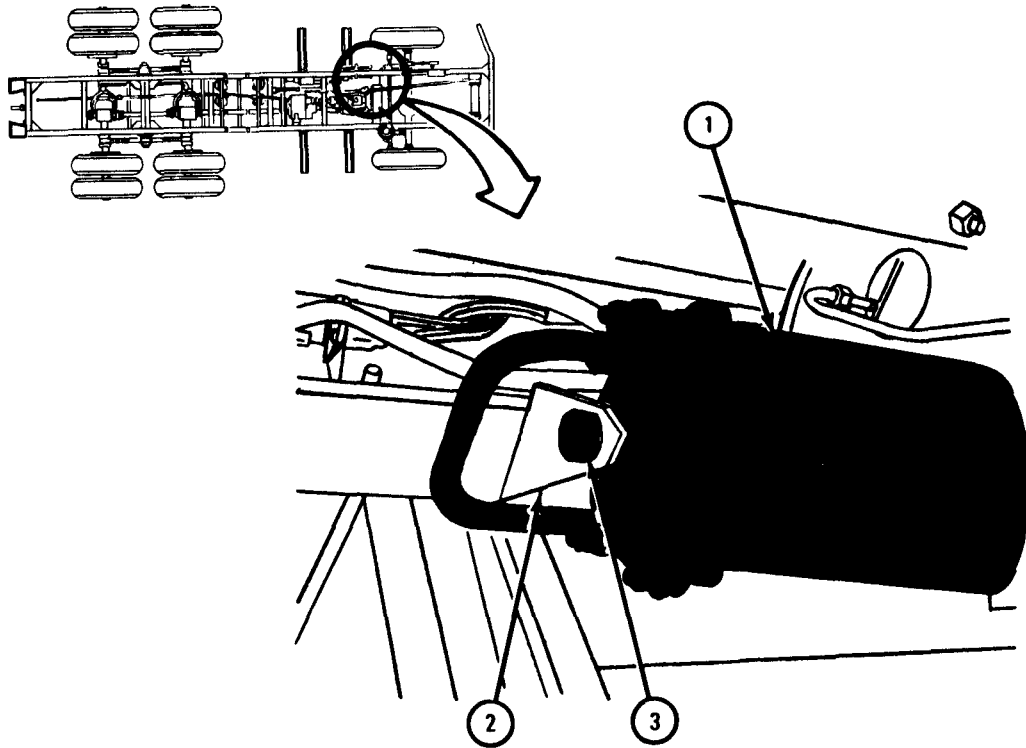

TA 046626

FRAME 2

1. Push stoplight plug (1) into connector (2) so knob (3) slides into groove (4).
GO TO FRAME 3

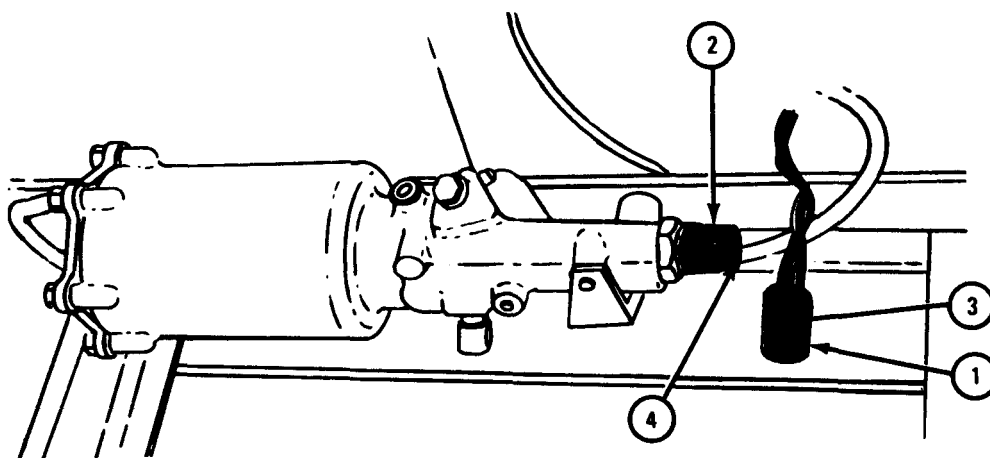

TA 046627

FRAME 3

1. Put trailer service air line (1) in place on fitting (2).
2. Using 5/8-inch open end wrench, screw on and tighten coupling nut (3).
3. Put air hydraulic cylinder airline (4) in place on fitting (5).
4. Using 1 3/16-inch combination box and open end wrench, screw on and tighten coupling nut (6).
5. Put air hydraulic cylinder breather line (7) in place on fitting (8).
6. Using 5/8-inch open end wrench, screw on and tighten coupling nut (9).

GO TO FRAME 4

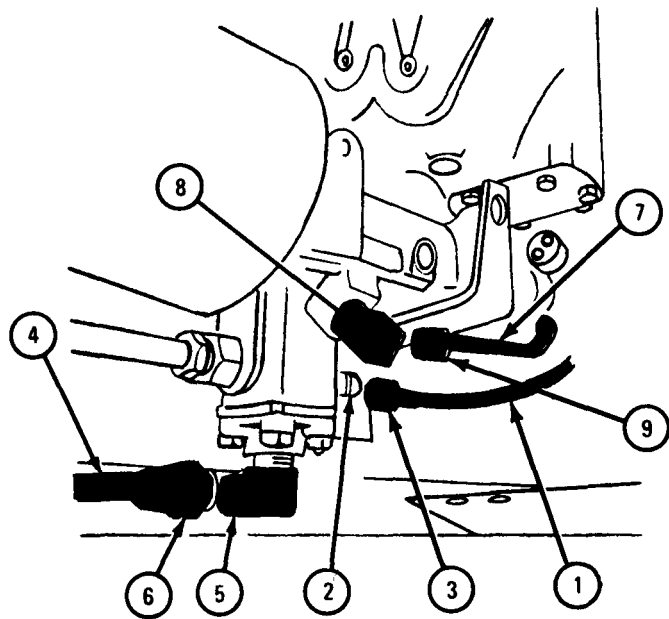

TA 046628

FRAME 4

1. Put air hydraulic cylinder hydraulic line (1) in place as shown.
2. Using 1/2-inch open end wrench, screw on and tighten coupling nut (2).
3. Put master cylinder hydraulic line (3) in place as shown.
4. Using 1/2-inch open end wrench, screw on and tighten coupling nut (4).

GO TO FRAME 5

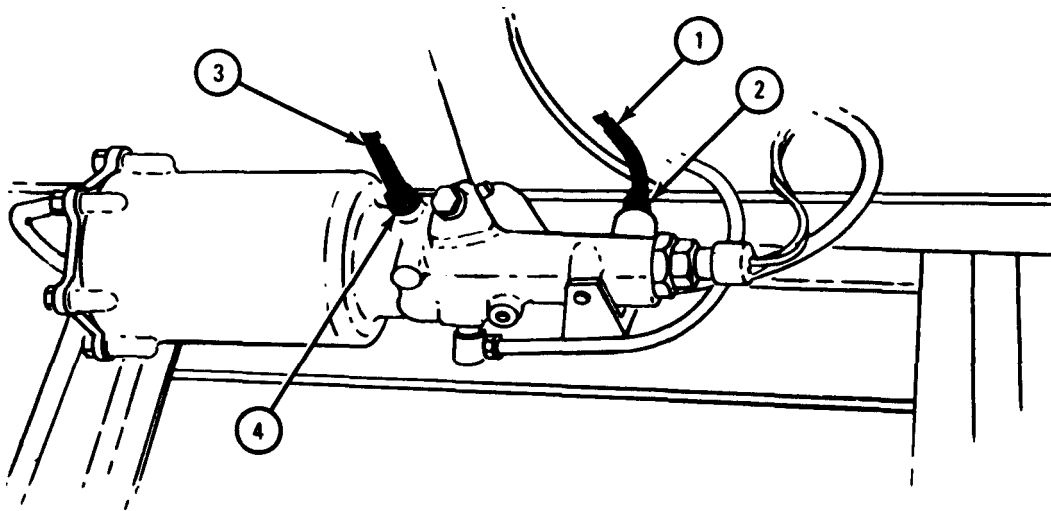

TA 046629

FRAME 5

1. Put shield (1) in place, alining two holes.
2. Using 5/8-inch socket wrench, screw in and tighten two screws (2).

NOTE

Follow-on Maintenance Action Required:

1. Bleed brake hydraulic system. Refer to para 13-15 and 13-16.
2. Check air system for leaks. Refer to Part 1, para 1-5.
3. Check service brake operation. Refer to TM 9-2320-209-10.

END OF TASK

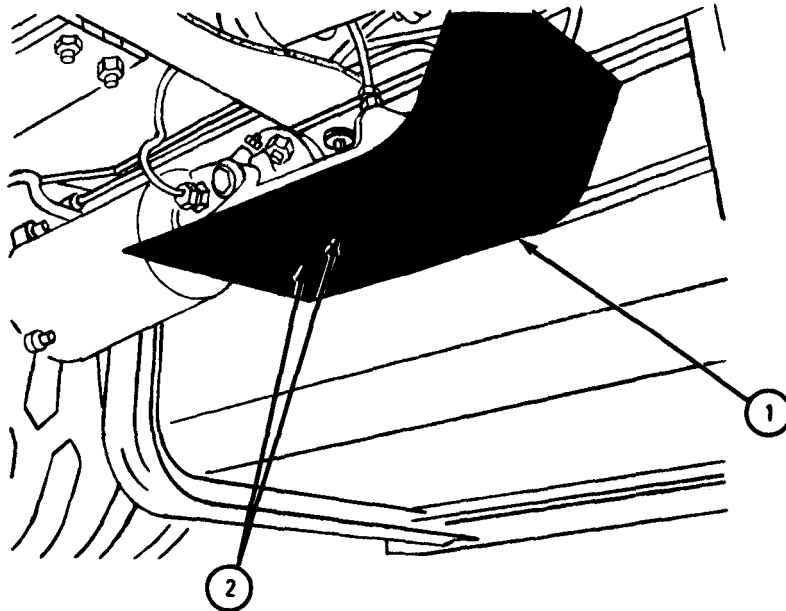

TA 046630

13-15. BLEEDING SERVICE BRAKE SYSTEM USING BLEEDER TANK.

TOOLS: 3/4-inch open end wrench Bleeder tank
 3/8-inch open end wrench Adapter, pressure tank-to-master
 7/16-inch box end wrench cylinder, pn 11660069
 Bleeding hose Quick-disconnect fitting, hose to
 Transparent container, 2-quart adapter
 Flexible neck oil filler can

SUPPLIES: Hydraulic brake fluid, type HB, VV-B-680
 Clean cloth

PERSONNEL: One

EQUIPMENT CONDITION: Truck parked, engine off, handbrake set.

a. Connecting Bleeding Tank.

FRAME 1

1. Open master cylinder access hatch (1).
2. Using clean cloth, clean area around master cylinder filler cap (2).
3. Using 3/8-inch open end wrench, unscrew tube nut (3) and take off hydraulic tube (4).
4. Using 3/4-inch open end wrench, unscrew and take off master cylinder filler cap (2).
5. Using flexible neck filler can, fill master cylinder (5) to 1/2-inch from top. Fill with hydraulic brake fluid.

GO TO FRAME 2

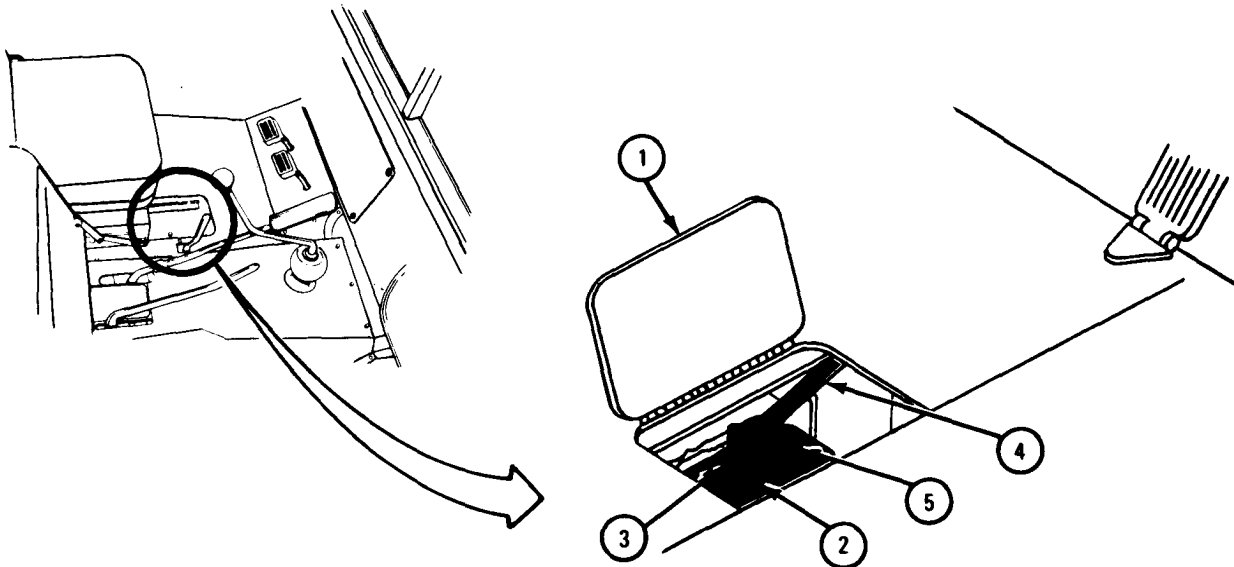

TA 047601

FRAME 2

1. Screw adapter (1) into filler opening of master cylinder (2).
2. Screw male quick-disconnect fitting (3) into adapter (1).

GO TO FRAME 3

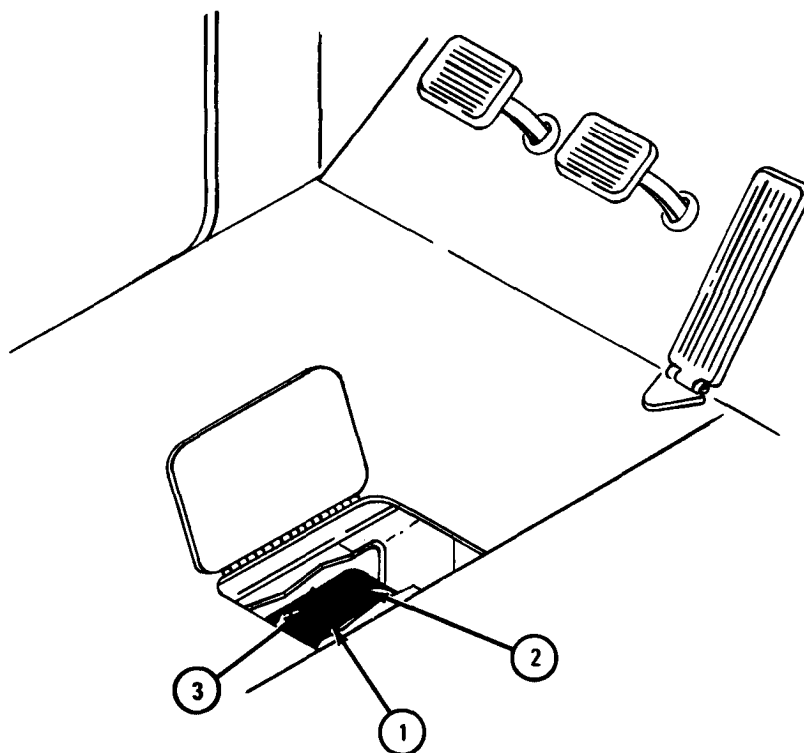

TA 047608

FRAME 3

1. Check that bleeder tank (1) is pressurized to between 20 and 30 pounds.
2. Make sure that valve (2) is open.
3. Press female quick disconnect on hose (3) onto male quick disconnect in adapter (4).

END OF TASK

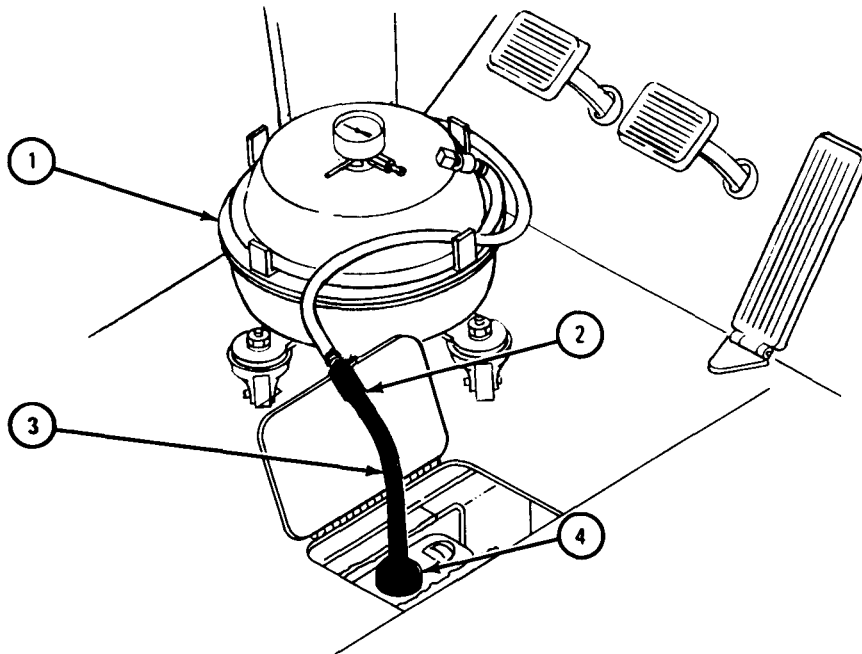

TA 047609

b. Bleeding Air Hydraulic Cylinder.

FRAME 1

1. Connect bleeding tank to master cylinder. Refer to para 13-15a.
2. Using clean cloth, clean bleeding screw (1) on air hydraulic cylinder (2).
3. Put one end of bleeding hose (3) on bleeding screw (1).
4. Put other end of bleeding hose (3) into transparent container (4). Put hydraulic brake fluid into container (4) until container is 1/2 full. Make sure that end of bleeding hose (3) is below level of fluid in container (4).

GO TO FRAME 2

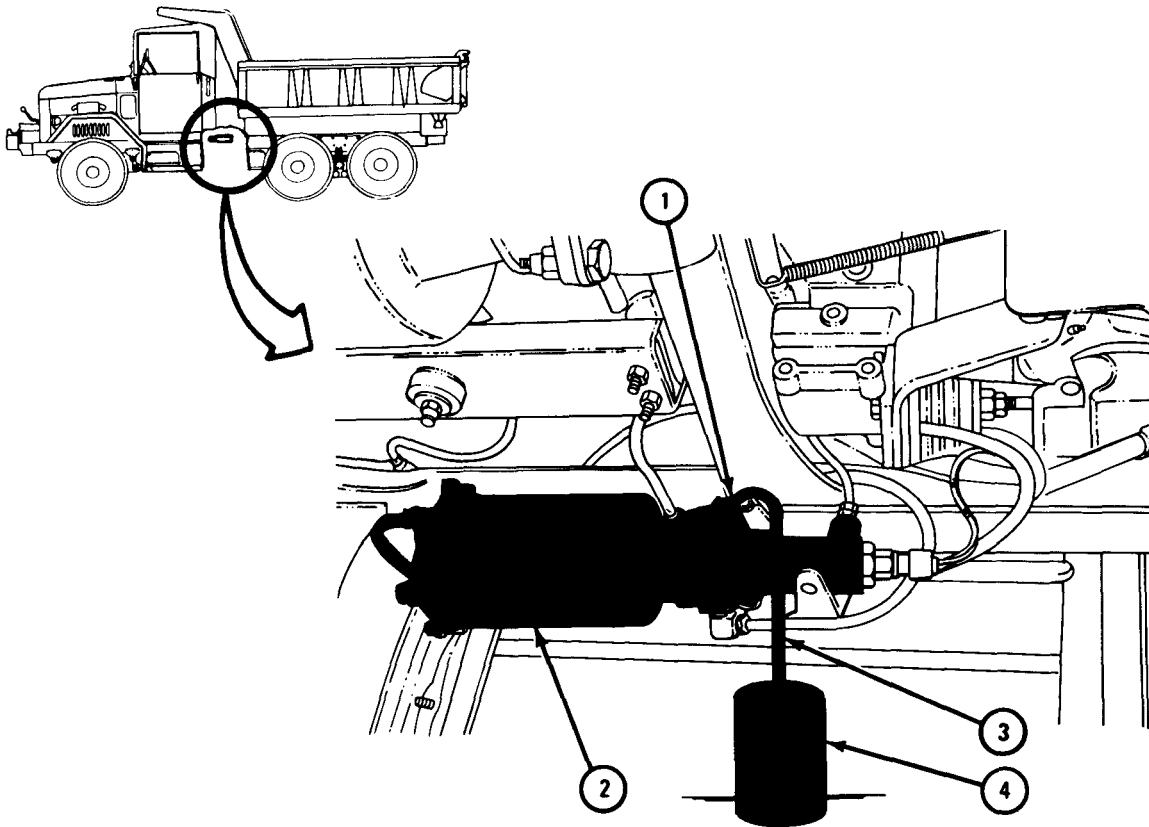

TA 047602

FRAME 2

1. Using 7/16-inch wrench, unscrew bleeding screw (1) 3/4 turn. Look for air bubbles in hydraulic fluid in container (2).
2. When there are no air bubbles for five seconds, use 7/16-inch wrench to close bleeding screw (1). Make sure that bleeding screw (1) is screwed on tightly.
3. Take bleeding hose off bleeding screw (1) and out of container (2). Dump hydraulic brake fluid in container (2) in approved area.
4. Disconnect bleeding tank from master cylinder. Refer to para 13-15d.

NOTE

Bleeding tank may be left connected to master cylinder if needed to bleed wheel cylinders.

END OF TASK

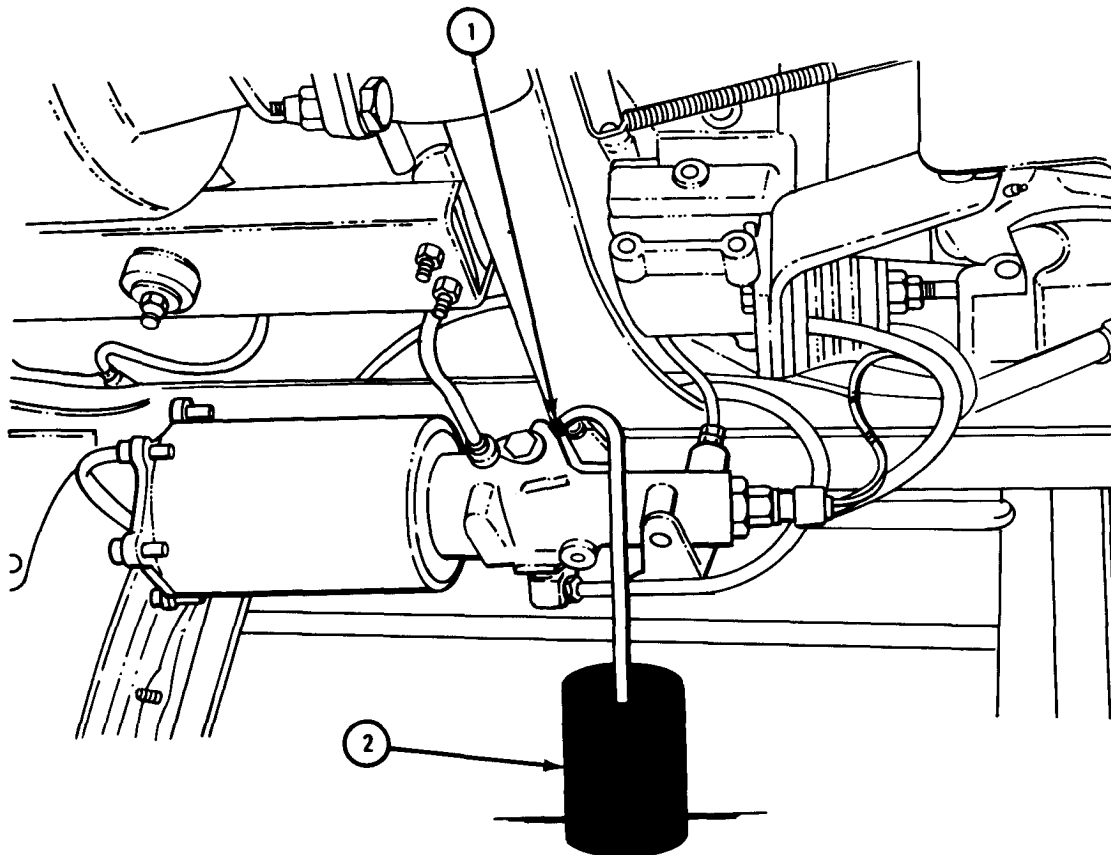

TA 047603

c. Bleeding Wheel Cylinders.

CAUTION

Air-hydraulic cylinder must be bled before bleeding wheel cylinders or brakes will not work properly.

NOTE

When a brake line has been taken off at only one wheel, bleed the wheel cylinder at that wheel only.

When all wheel cylinders must be bled, start with wheel cylinder farthest away from master cylinder.

FRAME 1

1. Connect bleeding tank to master cylinder. Refer to para 13-15a.
2. Using clean cloth, clean bleeding screw (1).
3. Put one end of bleeding hose (2) on bleeding screw (1).
4. Put other end of bleeding hose (2) into transparent container (3). Put hydraulic fluid into container (3) until container is 1/2 full. Make sure that end of bleeding hose is below level of fluid in container.

GO TO FRAME 2

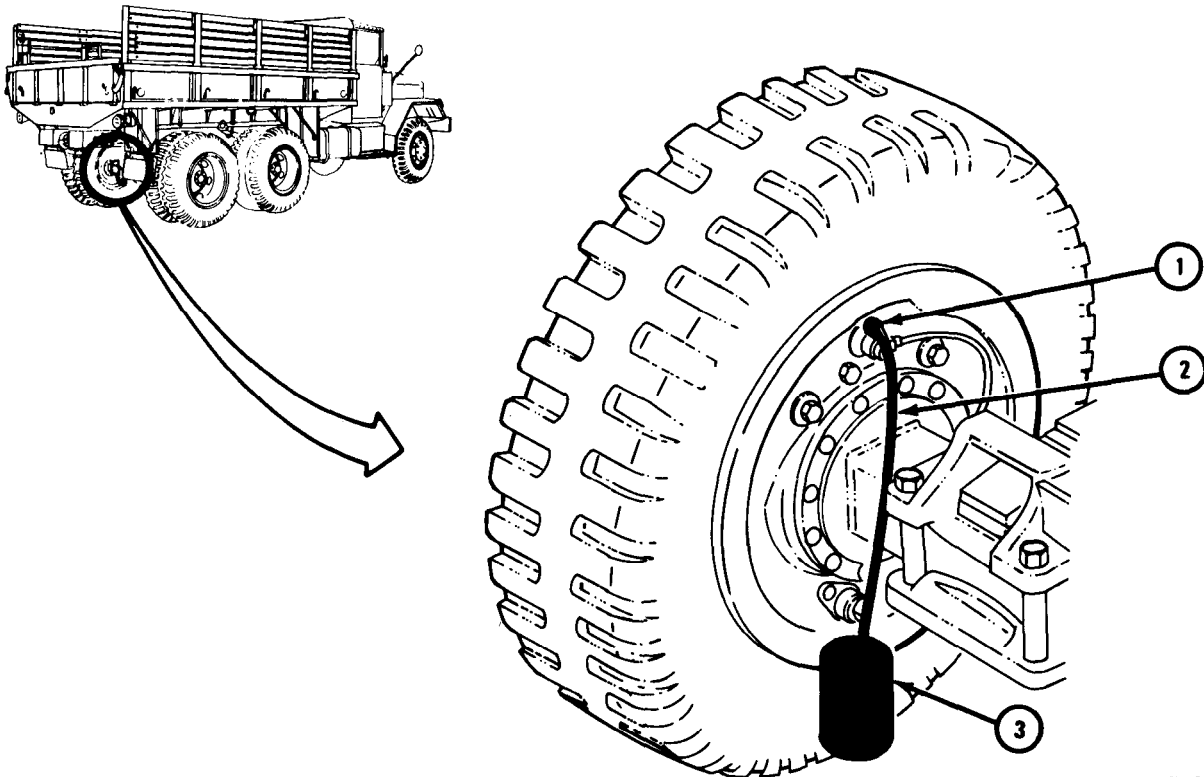

TA 047605

FRAME 2

1. Using a 7/16-inch wrench, unscrew bleeding screw (1) 3/4 turn. Look for air bubbles in hydraulic fluid in container (2).
2. When there are no air bubbles for five seconds, use 7/16-inch wrench to close bleeding screw (1). Make sure that bleeding screw (1) is screwed on tightly.
3. Take bleeding hose (3) off bleeding screw (1) and out of container (2). Dump hydraulic fluid in container (2) in the approved area.
4. Disconnect bleeding tank from master cylinder. Refer to para 13-15d.

END OF TASK

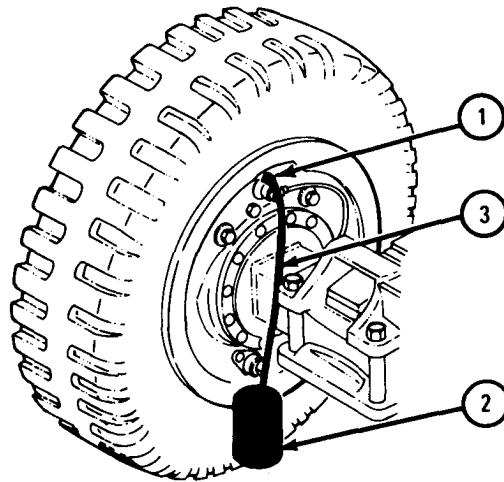

TA 047610

d. Disconnecting Bleeder Tank.

FRAME 1

1. Take female quick disconnect on hose (1) out of male quick disconnect in adapter (2).

2. Take away bleeder tank (3).

GO TO FRAME 2

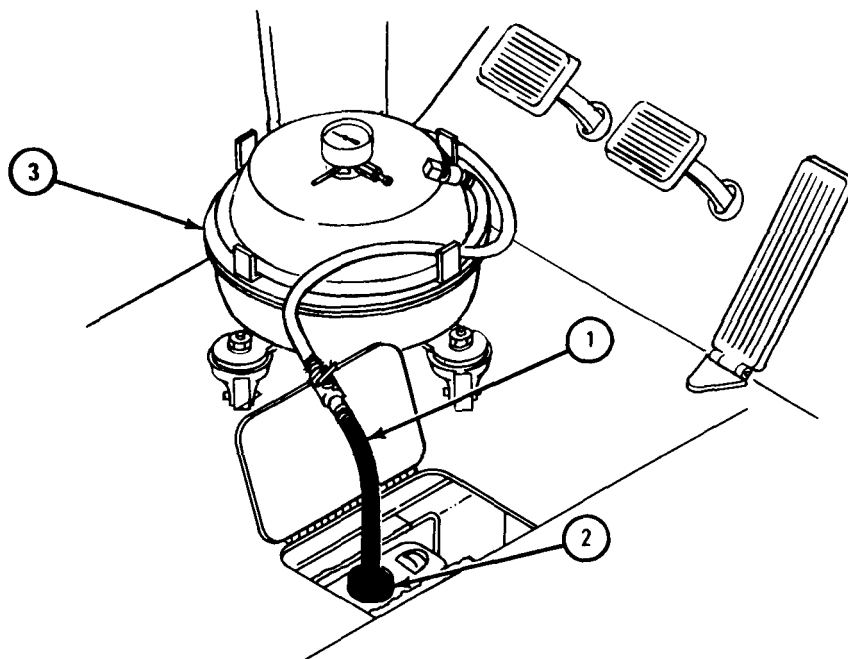

TA 047611

FRAME 2

1. Unscrew and take out male quick disconnect fitting (1) from adapter (2).
2. Unscrew and take out adapter (2) from master cylinder (3).

GO TO FRAME 3

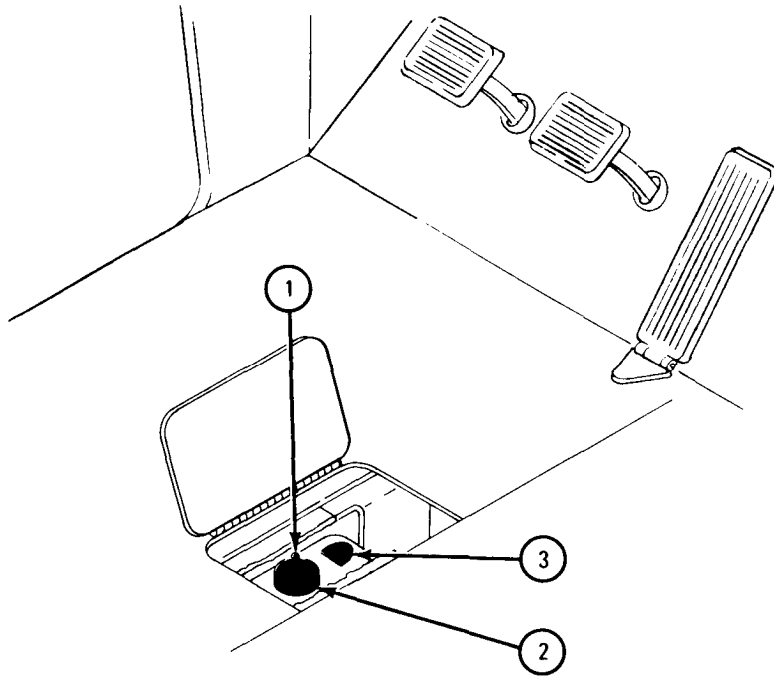

TA 047612

FRAME 3

1. Screw master cylinder filler cap (1) into master cylinder (2).
2. Connect hydraulic tube (3) to master cylinder filler cap (1) and screw in tube nut (4).
3. Using 3/8-inch open end wrench, tighten tube nut (4).
4. Close master cylinder access hatch (5).

END OF TASK

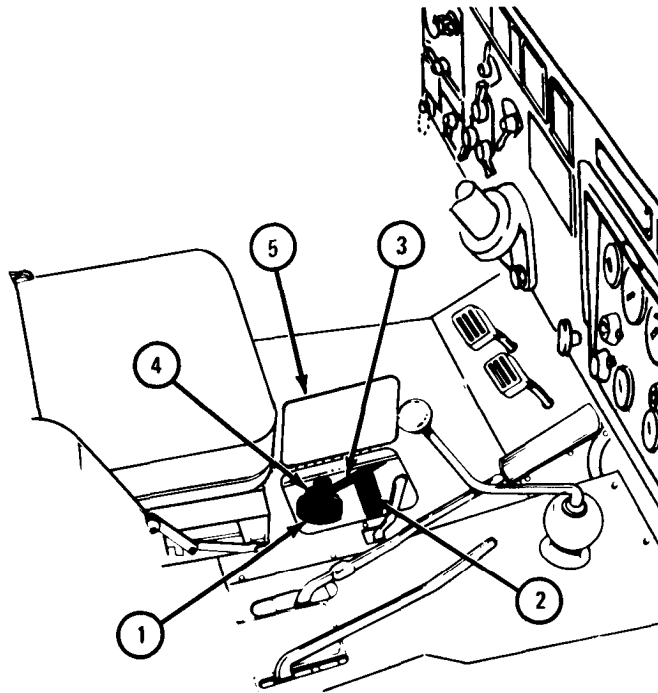

TA 047613

13-16. BLEEDING SERVICE BRAKE SYSTEM WITHOUT USING BLEEDER TANK.

TOOLS: 3/4-inch open end wrench
 7/16-inch box end wrench
 Bleeding hose
 Transparent container, 2-quart capacity
 Flexible neck filler can

SUPPLIES: Hydraulic brake fluid, type HB, VV-B-680
 Clean cloth

PERSONNEL: Two

EQUIPMENT CONDITION: Truck parked over maintenance bay, engine off,
 handbrake set.

a. Filling Master Cylinder.

FRAME 1

1. Open master cylinder access hatch (1).
2. Using 3/4-inch wrench, unscrew and take off master cylinder filler cap (2).
3. Using flexible neck filler can, fill master cylinder (3) to 1/2 inch from top. Fill with hydraulic brake fluid.
4. Using 3/4-inch wrench, screw on master cylinder filler cap (2).
5. Close master cylinder access hatch (1).

END OF TASK

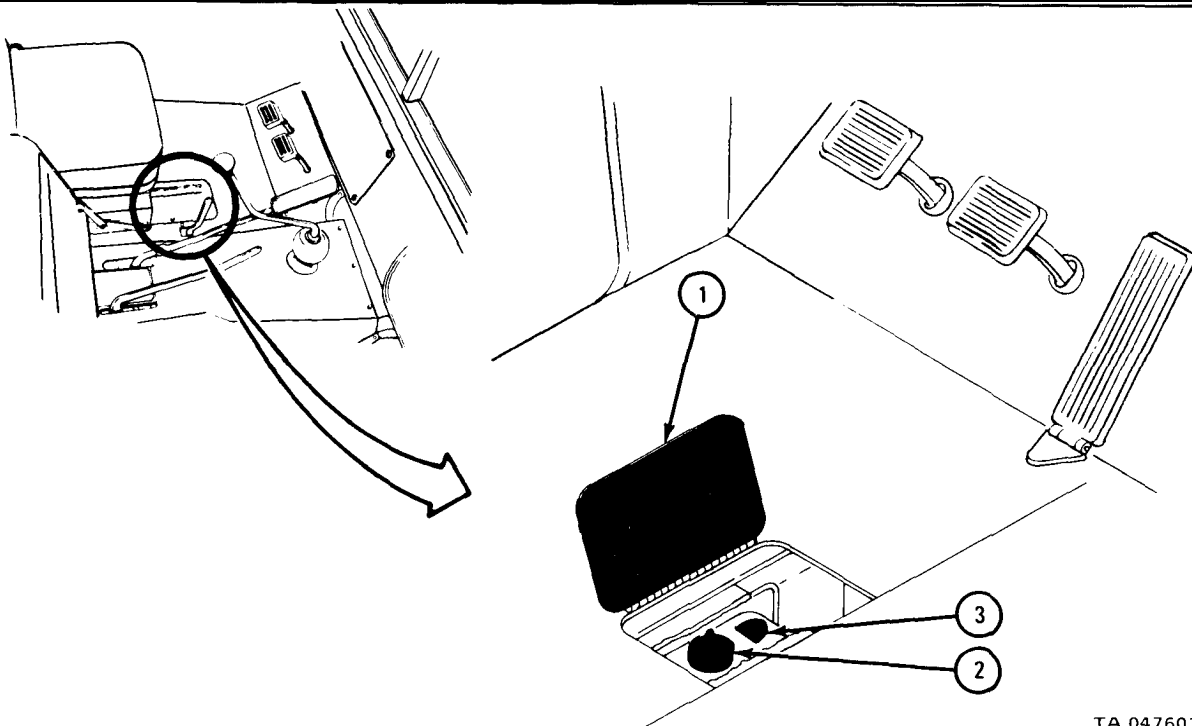

TA 047601

b. Bleeding Air Hydraulic Cylinder.

FRAME 1

1. Fill master cylinder. Refer to para 13-16a.
2. Using clean cloth, clean bleeding screw (1) on air hydraulic cylinder (2).
3. Put one end of bleeding hose (3) on bleeding screw (1).
4. Put other end of bleeding hose (3) into transparent container (4). Put hydraulic fluid into container until container is 1/2 full. Make sure that end of bleeding hose (3) is below level of fluid in container (4).

GO TO FRAME 2

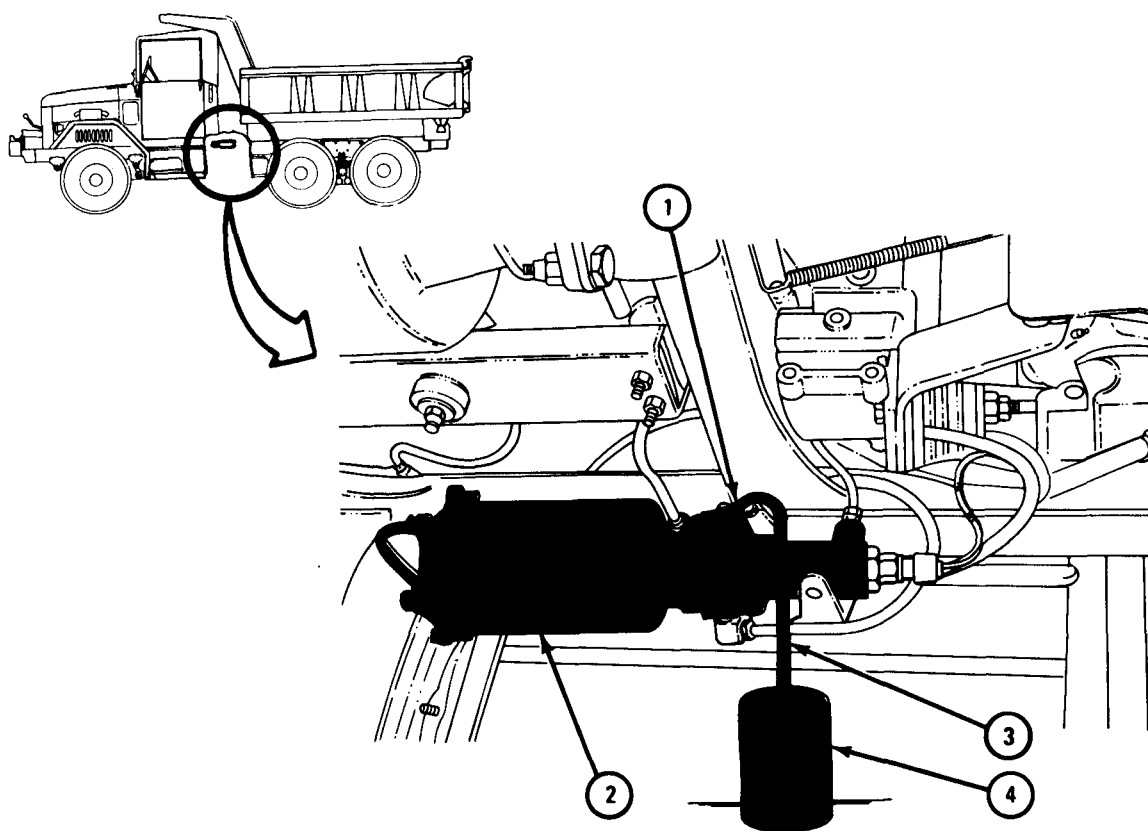

TA 047602

FRAME 2

- Soldier A 1. Using 7/16-inch wrench, unscrew bleeding screw (1) 3/4 turn. Tell soldier B to slowly pump brake pedal three times and hold pedal down after last pump.
- Soldier B 2. Slowly pump brake pedal three times. Hold pedal down after last pump until told to let pedal up. Tell soldier A when pedal is being held down.
- Soldier A 3. Look for air bubbles in hydraulic fluid in container (2). Using 7/16-inch wrench, screw on bleeding screw (1). Tell soldier B to let brake pedal up and to fill master cylinder.
- Soldier B 4. Fill master cylinder. Refer to para 13-16a. Tell soldier A when master cylinder has been filled.
- Soldiers A and B 5. Do steps 1 through 4 again as often as needed until there are no air bubbles.

GO TO FRAME 3

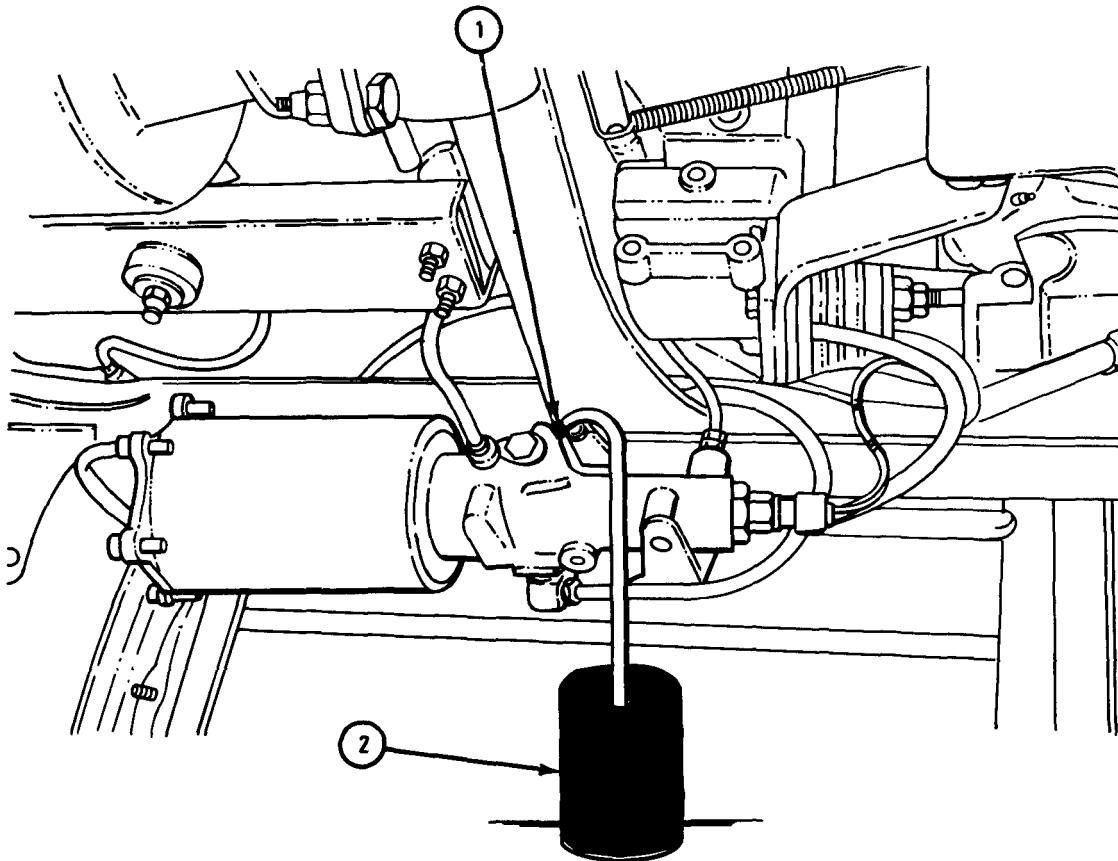

TA 047603

FRAME 3

1. Take bleeding hose (1) off bleeding screw (2) and out of container (3).
Make sure that bleeding screw (2) is screwed on tightly.
2. Dump hydraulic fluid in container (3) in approved disposal area.
3. Make sure that master cylinder is filled. Refer to para 13-16a.

END OF TASK

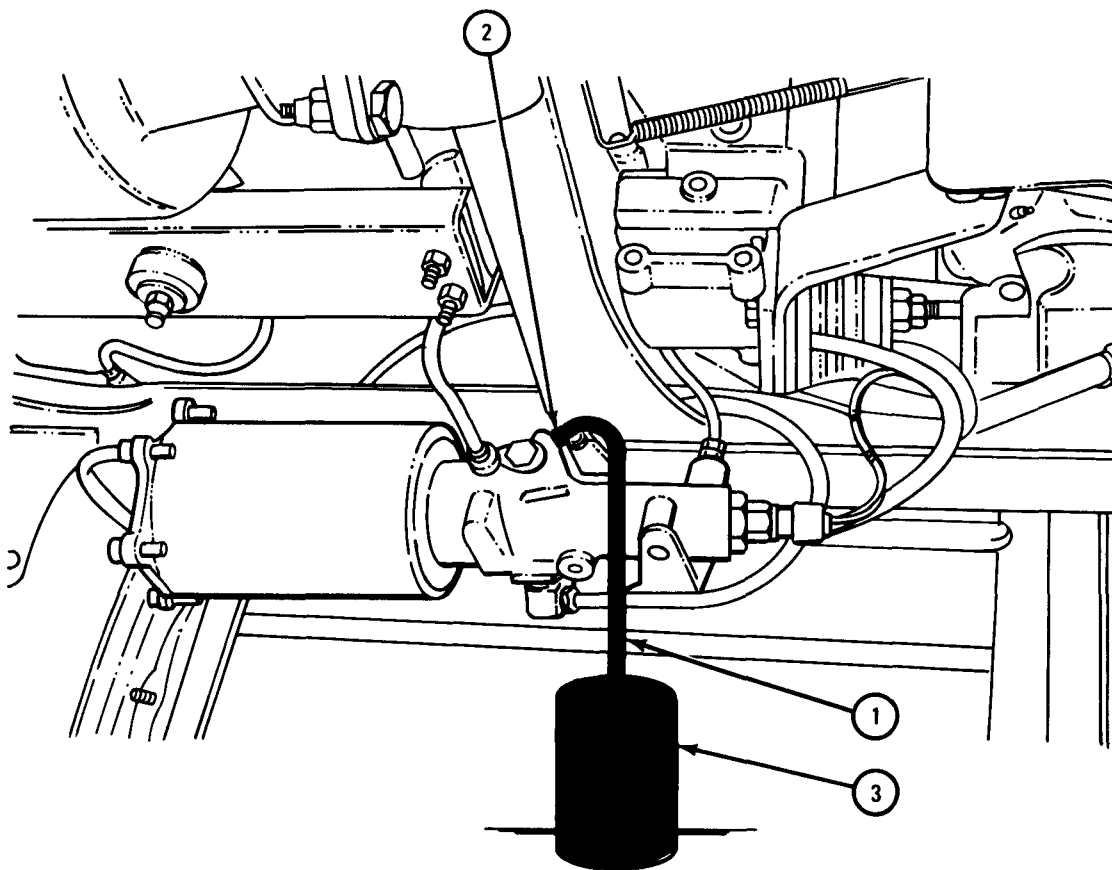

TA 047604

c. Bleeding Wheel Cylinders.CAUTION

Air hydraulic cylinder must be bled before bleeding wheel cylinders or brakes will not work properly.

NOTE

When a brake line has been taken off at only one wheel, bleed the wheel cylinders at that wheel only.

When all wheel cylinders must be bled, start with wheel cylinder furthest away from master cylinder.

FRAME 1

1. Fill master cylinder. Refer to para 13-16a.
2. Using clean cloth, clean bleeding screw (1).
3. Put one end of bleeding hose (2) on bleeding screw (1).
4. Put other end of bleeding hose (2) into transparent container (3). Put hydraulic fluid into container until it is 1/2-full. Make sure that end of bleeding hose (2) is below level of fluid in container (3).

GO TO FRAME 2

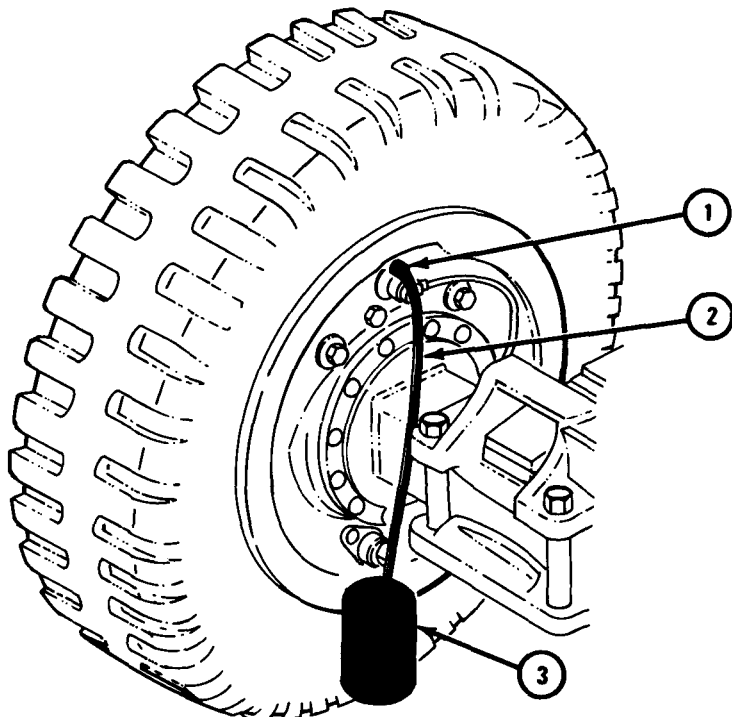
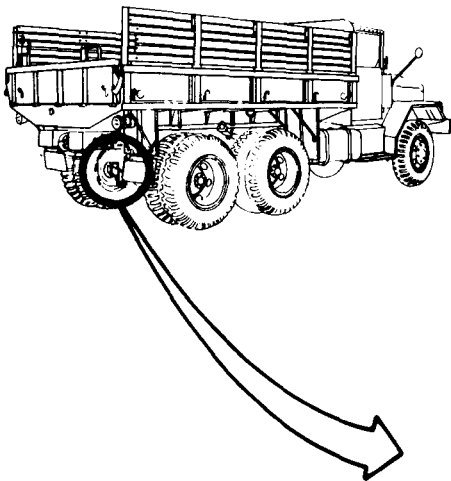

TA 047605

FRAME 2

- Soldier A 1. Using 7/16-inch wrench, unscrew bleeding screw (1) 3/4 turn. Tell soldier B to slowly pump brake pedal three times and hold pedal down after last pump.
- Soldier B 2. Slowly pump brake pedal three times. Hold pedal down after last pump until told to let pedal up. Tell soldier A when pedal is being held down.
- Soldier A 3. Look for air bubbles in hydraulic fluid in container (2). Using 7/16-inch wrench, screw on bleeding screw (1). Tell soldier B to let brake pedal up and to fill master cylinder.
- Soldier B 4. Fill master cylinder. Refer to para 13-16a. Tell soldier A when master cylinder has been filled.
- Soldiers A and B 5. Do steps 1 through 4 again as often as needed until there are no air bubbles.

GO TO FRAME 3

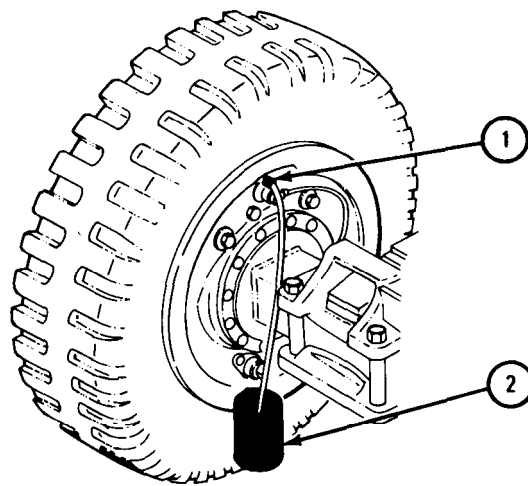

TA 047606

FRAME 3

1. Take bleeding hose (1) off bleeding screw (2) and out of container (3). Make sure that bleeding screw is screwed on tightly.
2. Dump hydraulic fluid in container (3) in approved disposal area.
3. Make sure that master cylinder is filled. Refer to para 13-16a.

END OF TASK

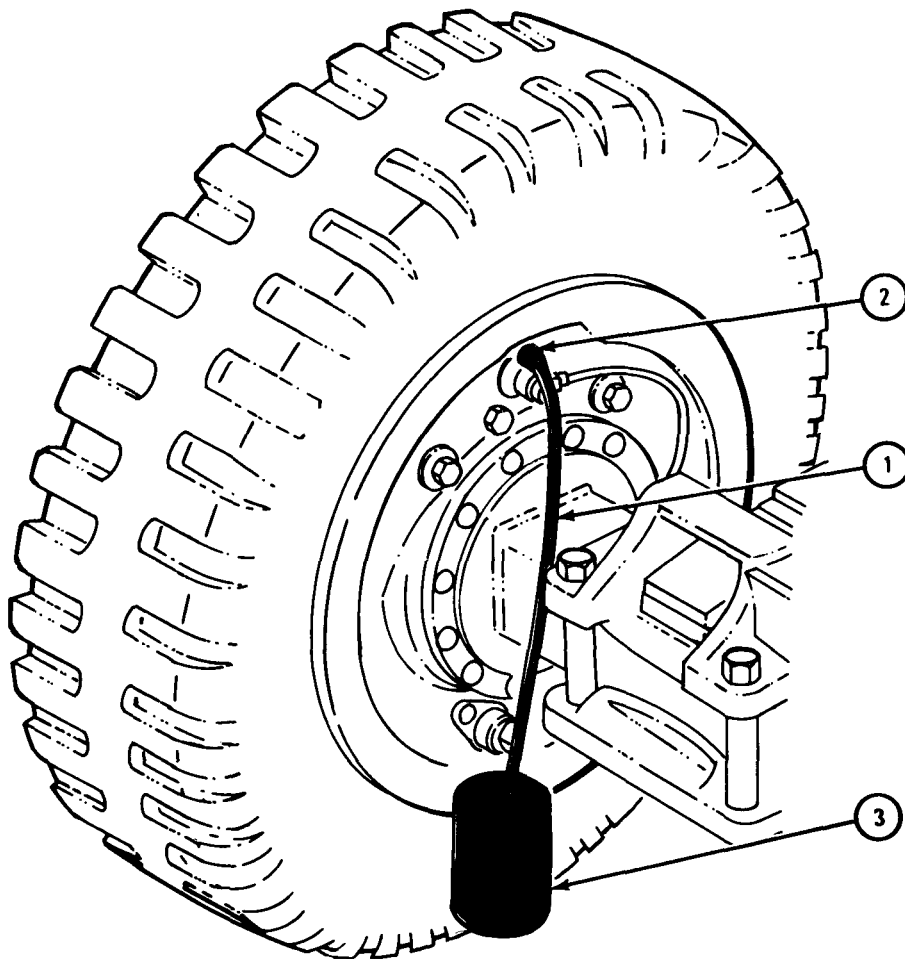

TA 047607

Section V. MECHANICAL BRAKE SYSTEM

13-17. BRAKE PEDAL REMOVAL AND REPLACEMENT.

TOOLS: Pliers 3/4-inch wrench (2)
Hammer 9/16-inch wrench (2)
Drift punch Prybar

SUPPLIES: None

PERSONNEL: One

EQUIPMENT CONDITION: Truck parked, engine off, handbrake set.

a. Preliminary Procedure. For trucks with power takeoff, tell direct support maintenance to remove power takeoff.

b. Removal.

FRAME 1

1. Using pliers, unhook clutch pedal return spring (1) and brake pedal return spring (2).
2. Using 3/4-inch wrenches, hold nut (3) and unscrew and take out screw (4).
3. Take off clutch control rod (5).

GO TO FRAME 2

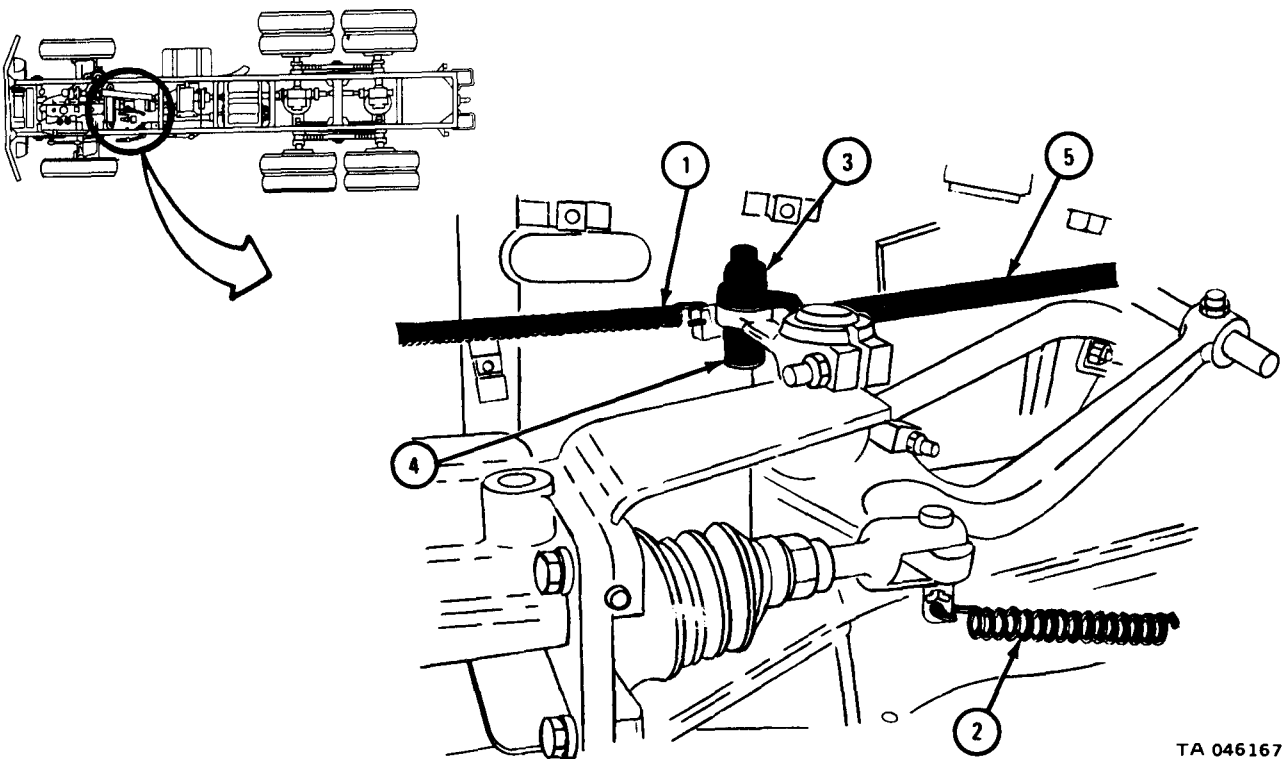

FRAME 2

1. Using 9/16-inch wrenches, hold nut (1) and unscrew and take out screw (2).
2. Using prybar, pry off clutch control lever (3).

GO TO FRAME 3

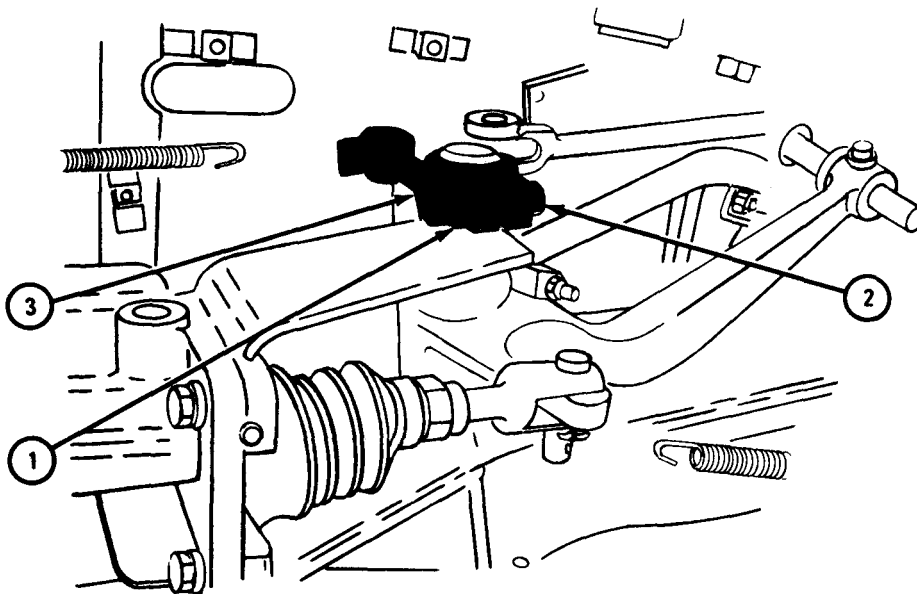

TA 087517

FRAME 3

1. Using 9/16-inch wrenches, hold nut (1) and loosen screw (2) until clutch pedal lever (3) is loose.
2. Using 9/16-inch wrench, unscrew and take out screw (4) and washer (5).
3. Using hammer and punch, tap clutch pedal (6) up and out of clutch pedal lever (3). Take off bumper (7).
4. Using prybar, pry off clutch pedal lever (3).
5. Using hammer and punch, tap out key (8).

GO TO FRAME 4

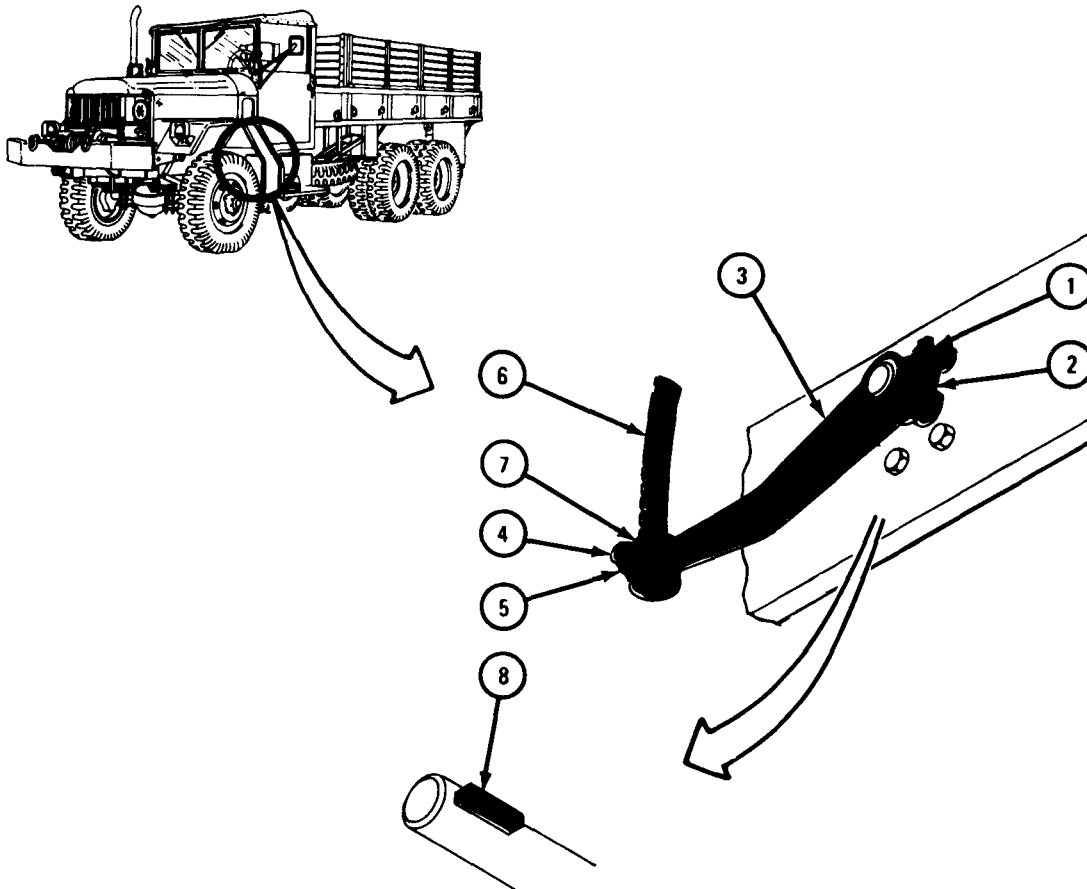

TA 046170

FRAME 4

1. Using 9/16-inch wrench, unscrew and take out screw (1) and washer (2).
 2. Using hammer and punch, tap brake pedal (3) out of brake pedal lever (4). Take off bumper (5).
 3. Using pliers, take out and throw away cotter pin (6). Take out clevis pin (7).
- GO TO FRAME 5

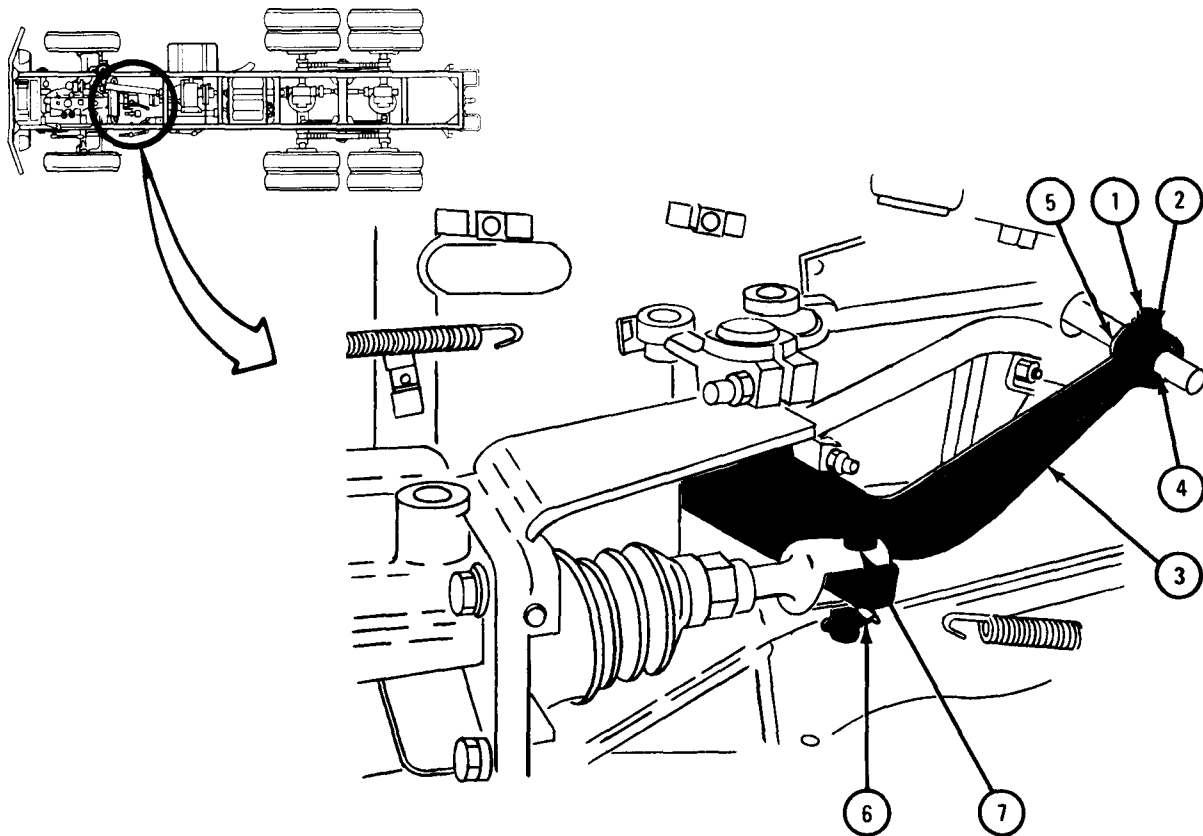

TA 083287

FRAME 5

1. Using hammer and punch, tap out key (1).
2. Hold brake pedal lever (2) and push out shaft (3).
3. Take out brake pedal lever (2).

END OF TASK

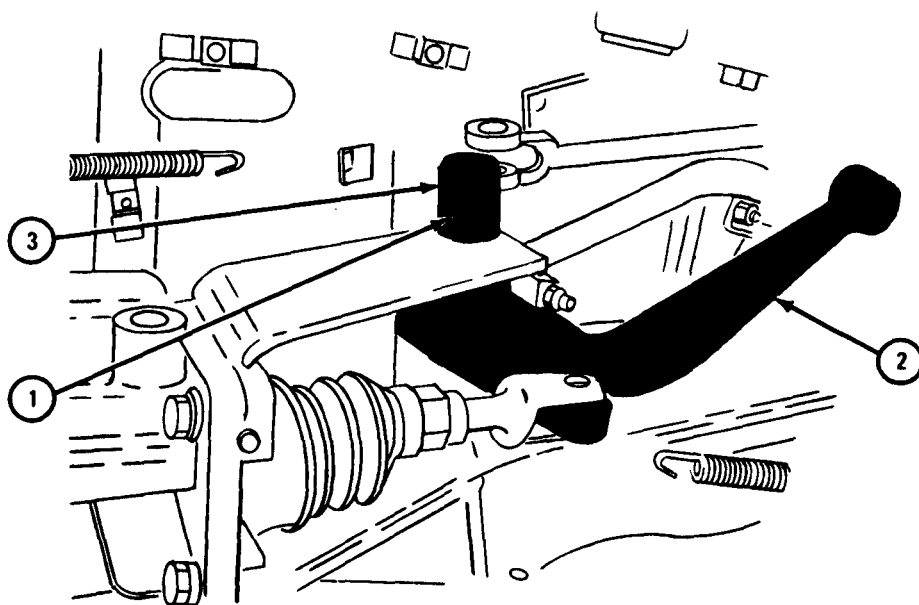

TA 087518

c. Replacement.

FRAME 1

1. Put brake pedal lever (1) into place and align holes.
2. Put in shaft (2).
3. Using hammer and punch, tap in key (3).

GO TO FRAME 2

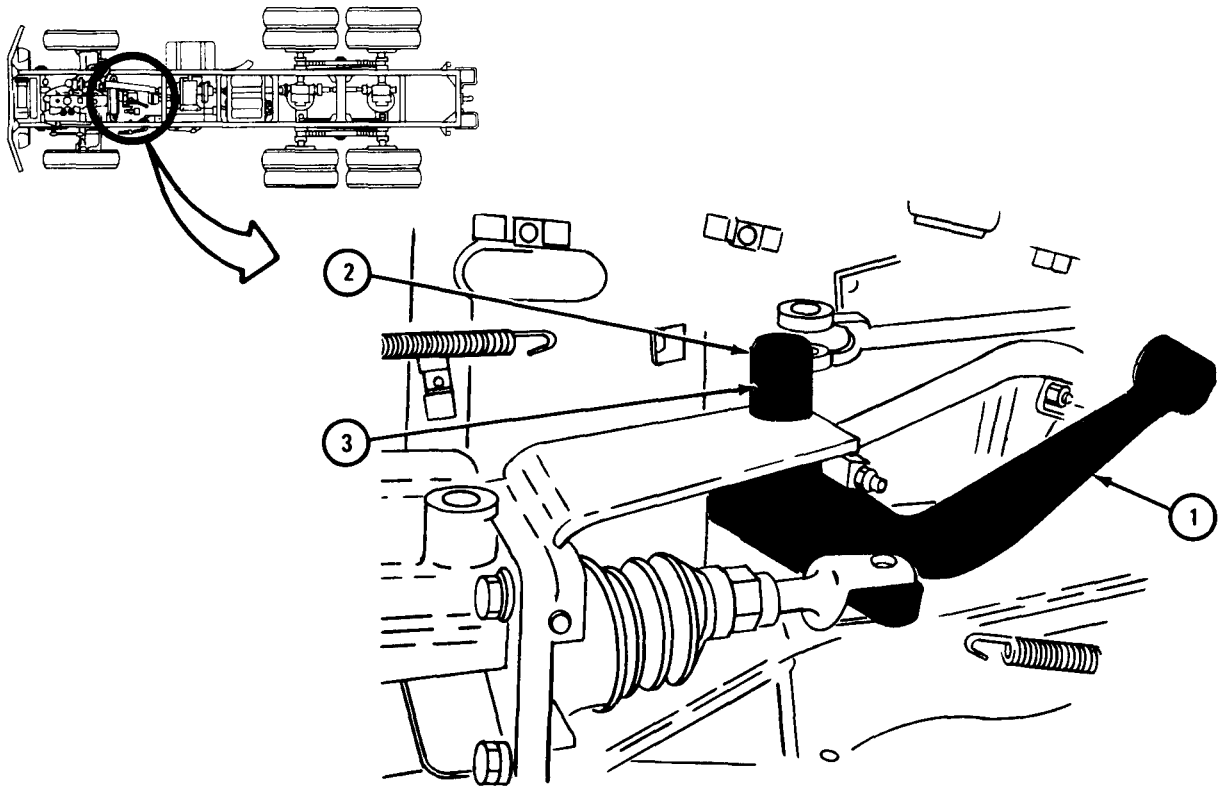

TA 046169

FRAME 2

1. Put on clutch control lever (1).
 2. Using 9/16-inch wrenches, hold nut (2) and screw in and tighten screw (3).
- GO TO FRAME 3

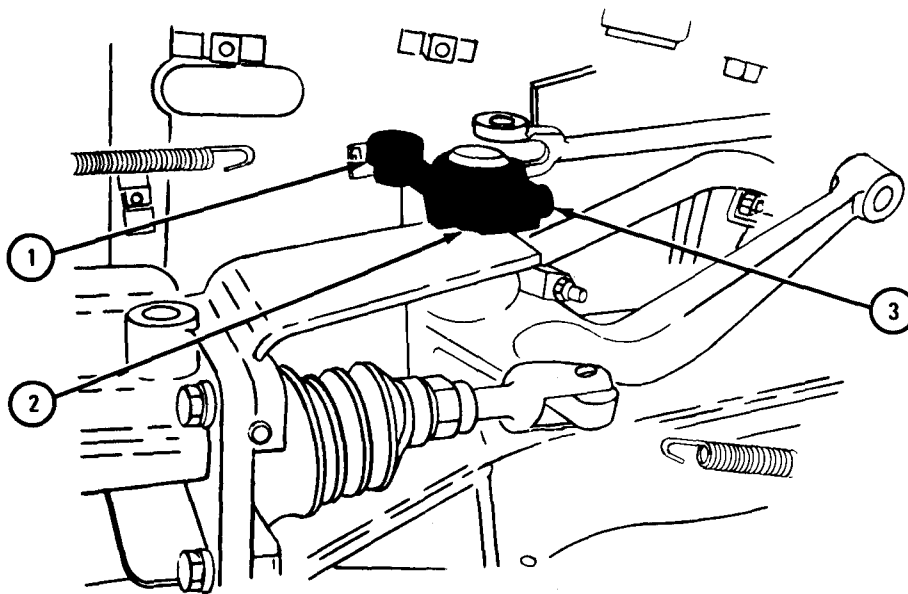

TA 088606

FRAME 3

1. Put bumper (1) and brake pedal lever (2) onto brake pedal (3).
2. Using 9/16-inch wrench, screw in and tighten washer (4) and screw (5).
3. Put rod yoke (6) into place and align hole in rod yoke with holes in brake pedal lever (2). Put in clevis pin (7).
4. Using pliers, put cotter pin (8) into inner hole and bend open ends of cotter pin.

GO TO FRAME 4

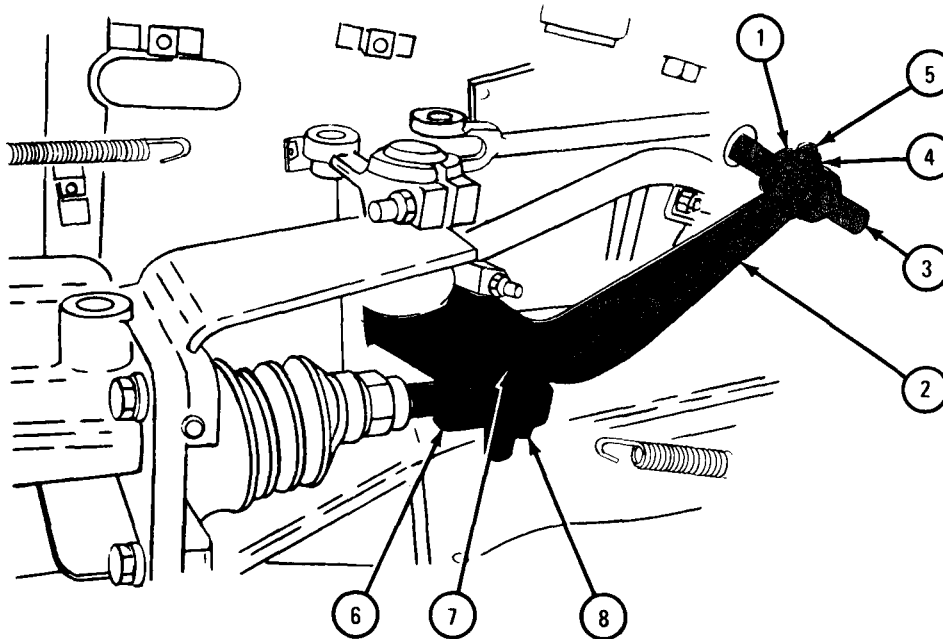

TA 087519

FRAME 4

1. Using hammer and punch, put in key (1). Slide clutch pedal lever (2) onto shaft (3) over key.
 2. Using 9/16-inch wrenches, hold nut (4) and screw in and tighten screw (5).
 3. Put bumper (6) and clutch pedal lever (2) on clutch pedal rod (7).
 4. Using 9/16-inch wrench, screw in and tighten washer (8) and screw (9).
- GO TO FRAME 5

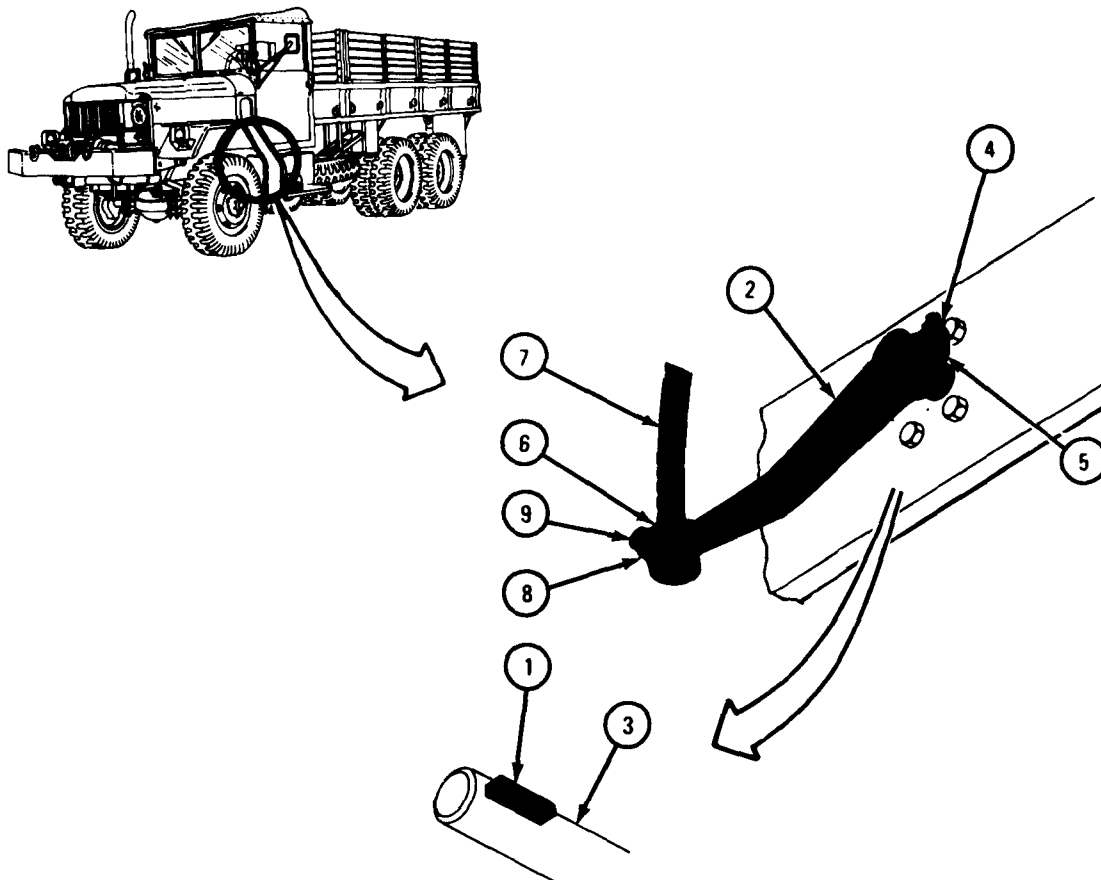

TA 087423

FRAME 5

1. Put clutch control rod yoke (1) on clutch control lever (2) and aline holes.
2. Using 3/4-inch wrenches, put in and hold screw (3) and screw on and tighten nut (4).
3. Using pliers, hook brake pedal return spring (5) into clevis pin (6).
4. Using pliers, hook clutch return spring (7) onto clutch control lever (2).

NOTE

Follow-on Maintenance Action Required:

For trucks with power takeoff, tell direct support maintenance to replace power takeoff.

END OF TASK

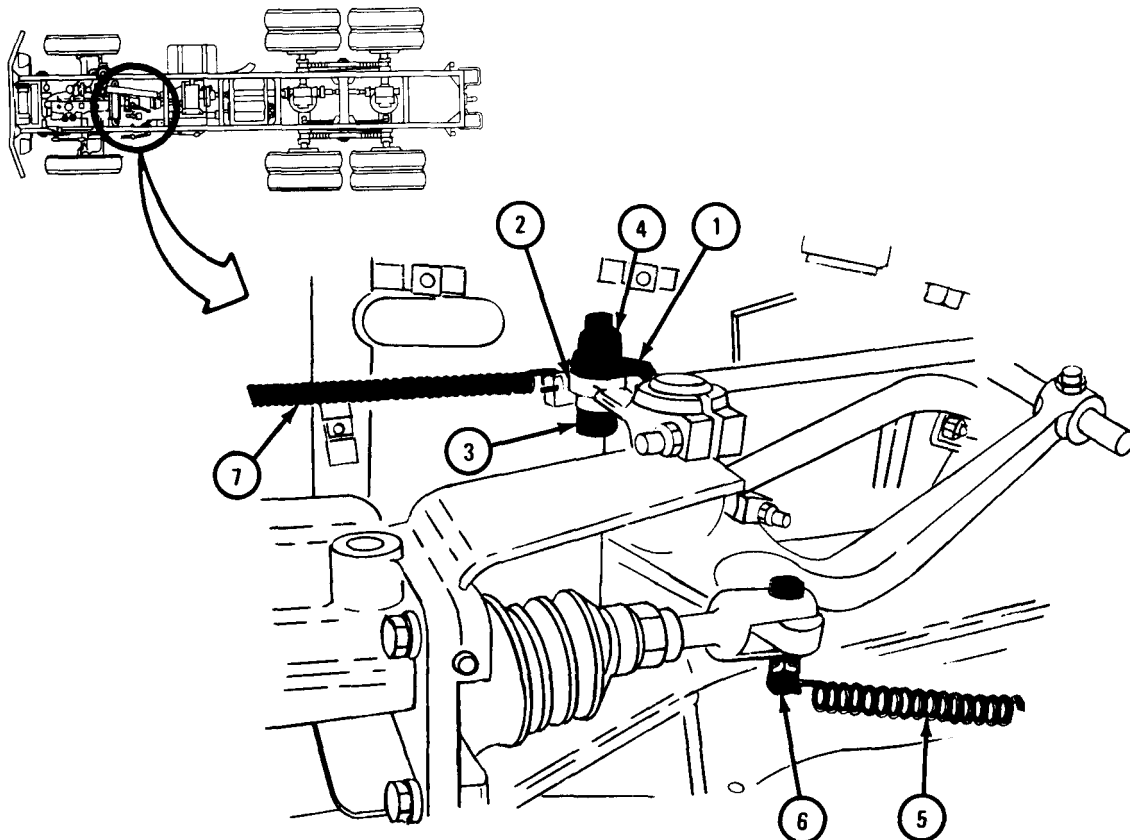

TA 083288

13-18. BRAKE PEDAL PAD REMOVAL AND REPLACEMENT.

TOOLS: None

SUPPLIES: None

PERSONNEL: One

EQUIPMENT CONDITION: Truck parked, engine off, handbrake set.

a. Removal.

FRAME 1

1. Using fingers, grasp edge of pad (1) at back of brake pedal (2).
2. Pull edge of pad (1) away to the side and lift up over brake pedal (2).
3. Pull pad (1) away from brake pedal (2).

END OF TASK

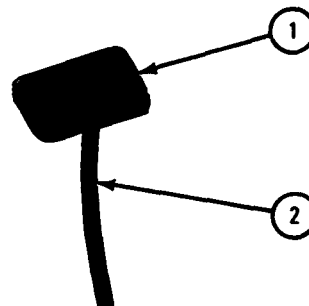
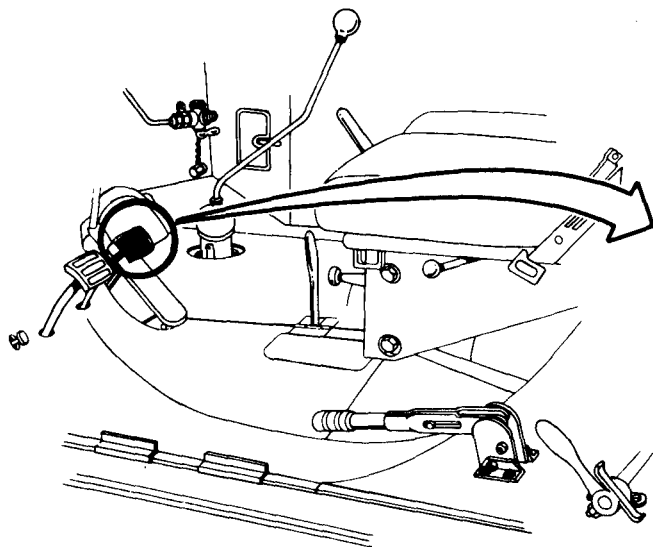

TA 046163

b . Replacement.**FRAME 1**

1. Using fingers, put top edge of pad (1) onto pedal (2).
2. Slide pad (1) down so the top edge hooks on pedal (2).
3. Pull left edge of pad (1) over left edge of pedal (2).
4. Pull right edge of pad (1) over right edge of pedal (2).
5. Pull bottom edge of pad (1) over bottom edge of pedal (2).

END OF TASK

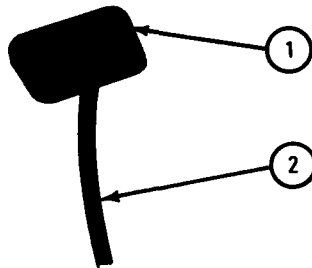

TA 046164

13-19. SERVICE BRAKE PEDAL ADJUSTMENT.

TOOLS: 6-inch ruler
7/8-inch wrench
Pliers
1-inch wrench

SUPPLIES: Marking chalk, SS-C-266F
Rag
Solvent, dry cleaning, type II (SD-2), Fed. Spec P-D-680

PERSONNEL: One

EQUIPMENT CONDITION: Truck parked, engine off, handbrake set.

FRAME 1

1. Using chalk, mark brake pedal (1) at floorboard (2).
2. Using hand, push brake pedal pad (3) down easily until free play is used up. Using chalk, mark brake pedal (1) at floorboard (2). Take hand away from brake pedal pad.
3. Using 6-inch ruler, measure between chalk marks. If measure is less than 1/4-inch, or more than 1/2-inch, free play is bad.

WARNING

Dry cleaning solvent is flammable. Do not use near an open flame. Keep a fire extinguisher nearby when solvent is used. Use only in well-ventilated places. Failure to do this may result in injury to personnel and damage to equipment.

4. Using rag and dry cleaning solvent, clean chalk marks off brake pedal (1).

IF FREE PLAY IS BAD, GO TO FRAME 2.

IF FREE PLAY IS GOOD, END OF TASK

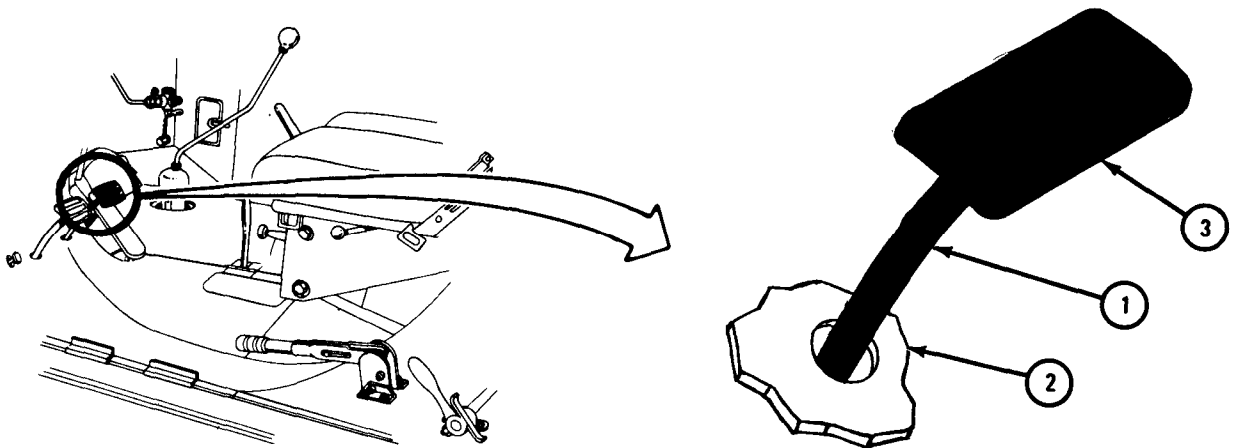

TA 046165

FRAME 2

1. Using pliers, take out spring (1) from clevis pin (2). Take out cotter pin (3).
2. Using 1-inch wrench, hold rod (4). Using 7/8-inch wrench, unscrew jamnut (5) partway.
3. Take out clevis pin (2).
4. Take rod end yoke (6) away from brake pedal lever (7).
5. If less free play is needed, unscrew rod end yoke (6) out a few turns. If more free play is needed, screw rod end yoke in a few turns.
6. Put rod end yoke (6) onto brake pedal lever (7). Line up holes and put clevis pin (2) through rod end yoke.
7. Using 7/8-inch wrench, tighten jamnut (5).
8. Hold 6-inch ruler to floorboard (8) and measure down to screw head (9). Using hand, pull brake pedal lever (7) until free play is used up. Using 6-inch ruler, measure distance to screw head.
9. If screw head (9) moved down 1/4 inch to 1/2 inch, go to step 10. If screw head did not move down 1/4 to 1/2 inch, do steps 2 through 8 again.
10. Put cotter pin (3) in clevis pin (2). Using pliers, spread cotter pin ends. Put spring (1) in clevis pin (2).

END OF TASK

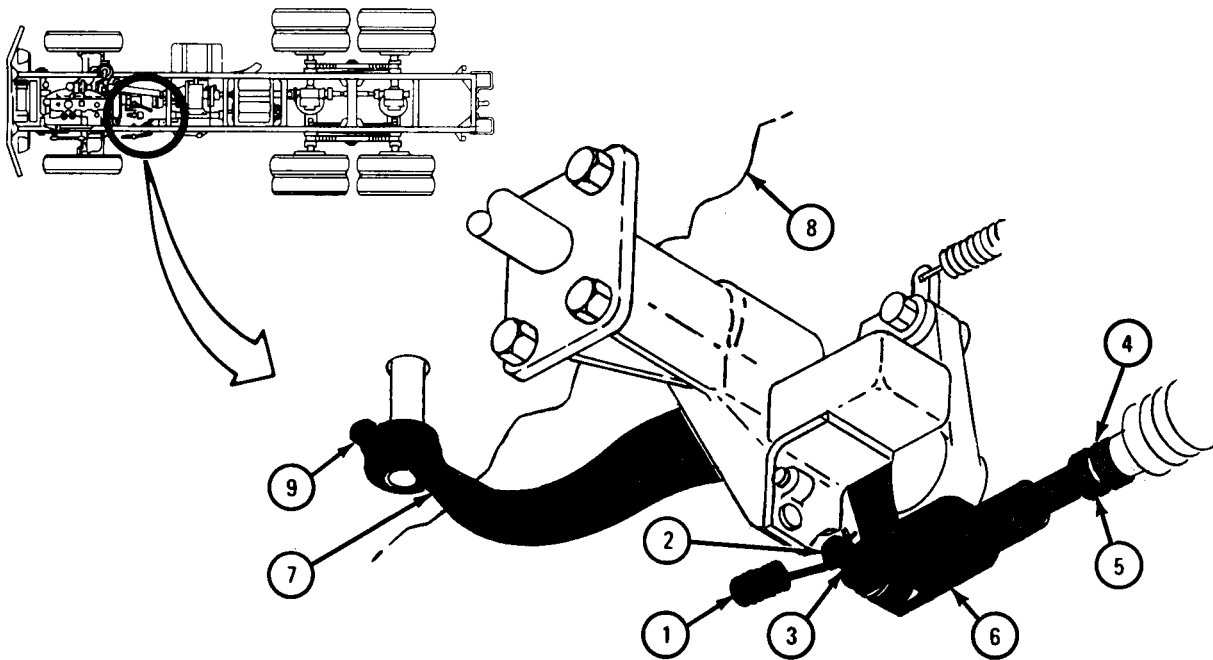

TA 046166

Section VI. AIR BRAKE SYSTEM

13-20. AIR SYSTEM PRESSURE VENTING.

TOOLS: None

SUPPLIES: None

PERSONNEL: One

EQUIPMENT CONDITION: Truck parked, engine off, handbrake set.

FRAME 1

1. The air reservoir drain cock (1) is located on different trucks in different places as shown.
2. Turn air reservoir drain cock (1) to the left 1/4 turn and let air pressure out of system.
3. When air flow stops, turn air reservoir drain cock (1) 1/4 turn to the right.

END OF TASK

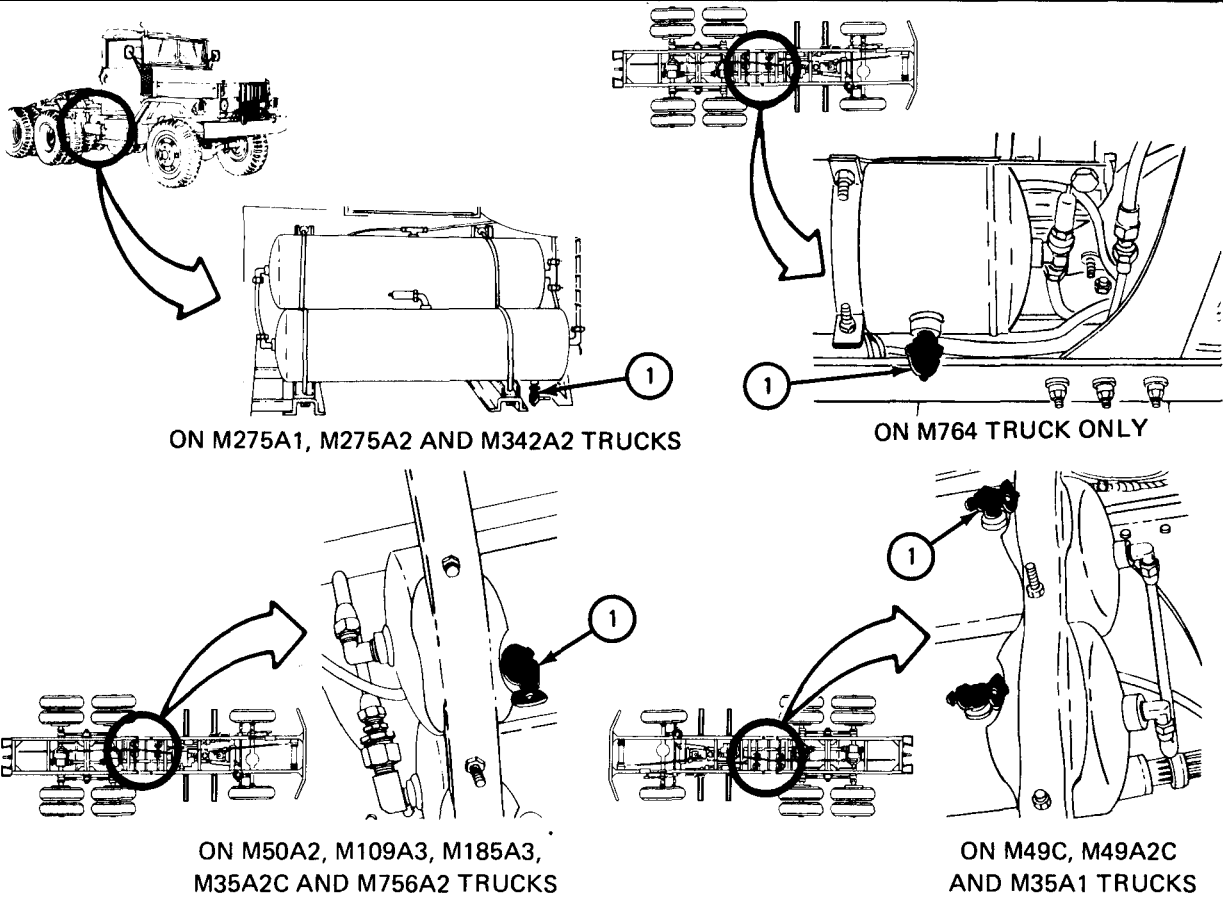

TA 084039

13-21. AIR SYSTEM LINES AND FITTINGS REMOVAL AND REPLACEMENT.

NOTE

Procedures given are typical and cover all the different types of installations that you will find on the trucks. Procedures do not show any one truck system. Refer to system schematic illustrations used as support diagrams for troubleshooting each system (vol. 2, chapter 46, fig. 46-2)

TOOLS: 5/8-inch combination box and open end box wrench
 3/8-inch combination box and open end box wrench
 9/16-inch open end wrench (2)
 3/4-inch combination box and open end box wrench
 11/16-inch combination box and open end box wrench
 13/16-inch combination box and open end box wrench
 Adjustable wrench
 7/8-inch combination box and open end box wrench
 1/2-inch drive ratchet
 9/16-inch socket

SUPPLIES: None

PERSONNEL: One

EQUIPMENT CONDITION: Truck parked, engine off, handbrake set.

a. Preliminary Procedure. Vent air system pressure. Refer to para 13-20.

b. Removal.

(1) Air lines and clamps.

NOTE

The air valve supply line at left rear of chassis on truck M275A2 is used for this typical procedure.

FRAME 1

1. Using 7/8-inch combination box and open end box wrench, unscrew and take off tube nut (1).
2. Using 3/4-inch combination box and open end box wrench, hold tee fitting (2).
3. Using 13/16-inch combination box and open end box wrench, unscrew and take off tube nut (3).

GO TO FRAME 2

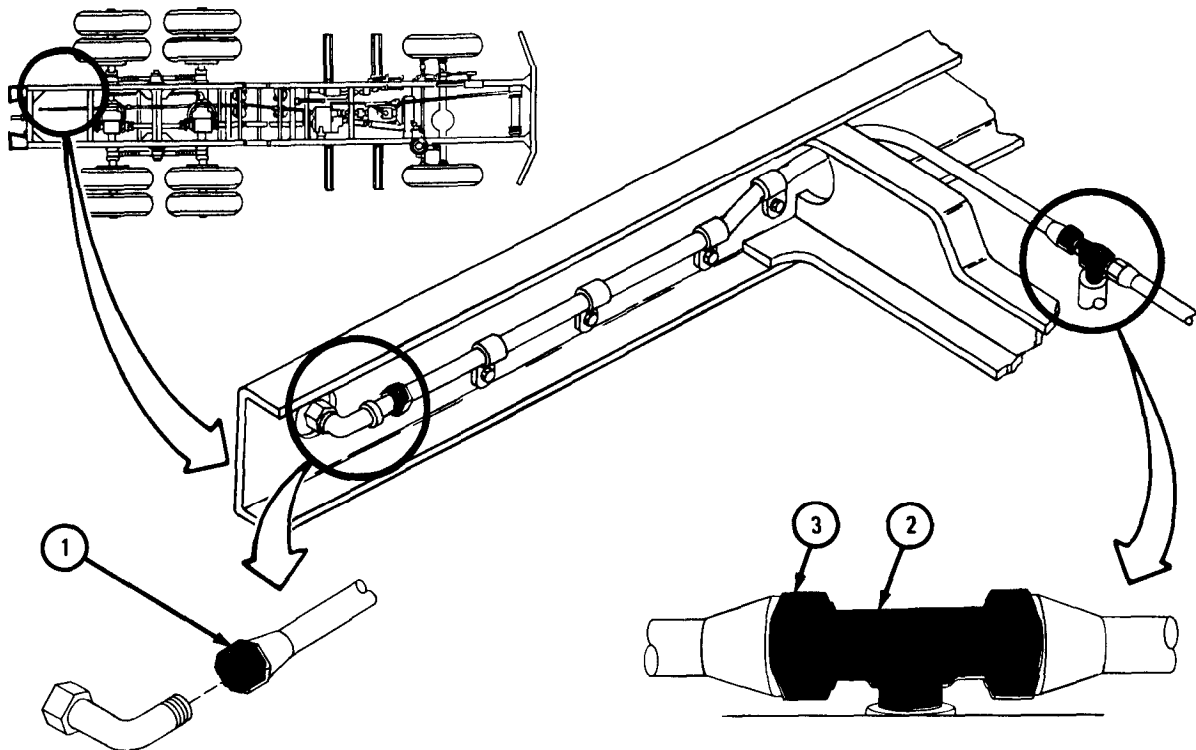

TA 083980

FRAME 2

1. Using 9/16-inch open end wrenches, hold capscrew (1). Using 1/2-inch drive ratchet and 9/16-inch socket, unscrew and take off locknut (2).

NOTE

There may be an electrical harness clamp (3) attached to capscrew (1). If there is, take it off after taking off locknut (2).

2. Do step 1 again for three tube clamps (4).
3. Take off air tube (5) and spread open and take off three tube clamps (4).

END OF TASK

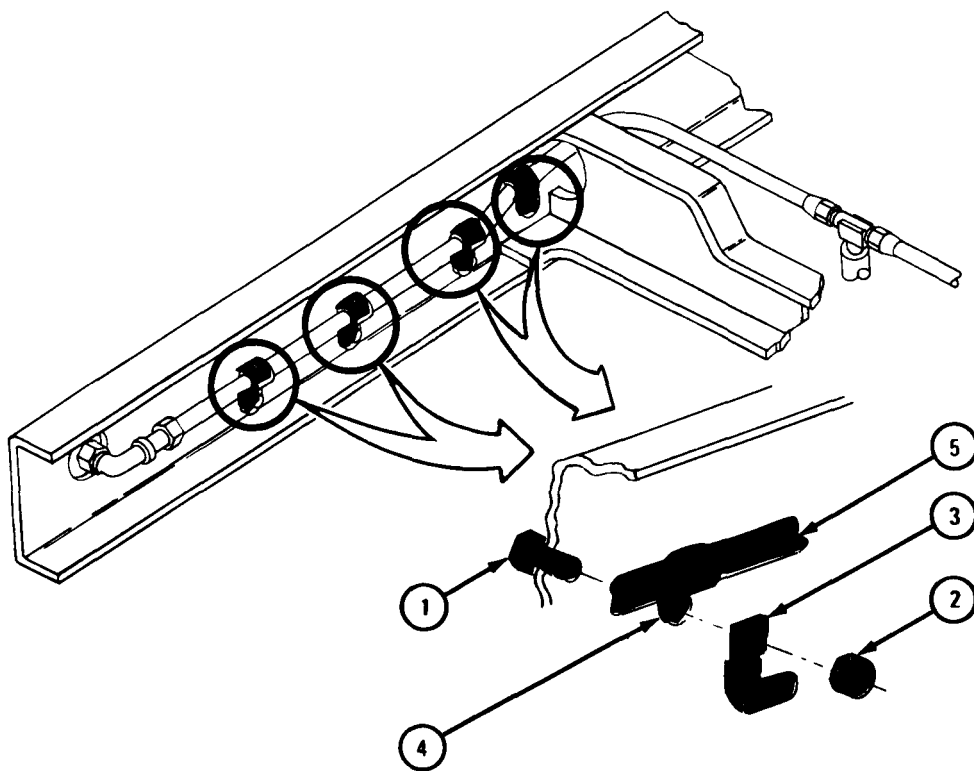

TA 083981

(2) Air tube fittings.

NOTE

The air tube connecting nipple on the left side of chassis on truck M764 is used for this typical procedure.

(a) Air tube connecting nipple

FRAME 1

1. Using 11/16-inch combination box and open end box wrench, hold adapter fitting (1). Using 7/8-inch combination box and open end box wrench, unscrew and take off tube nuts (2 and 3).

END OF TASK

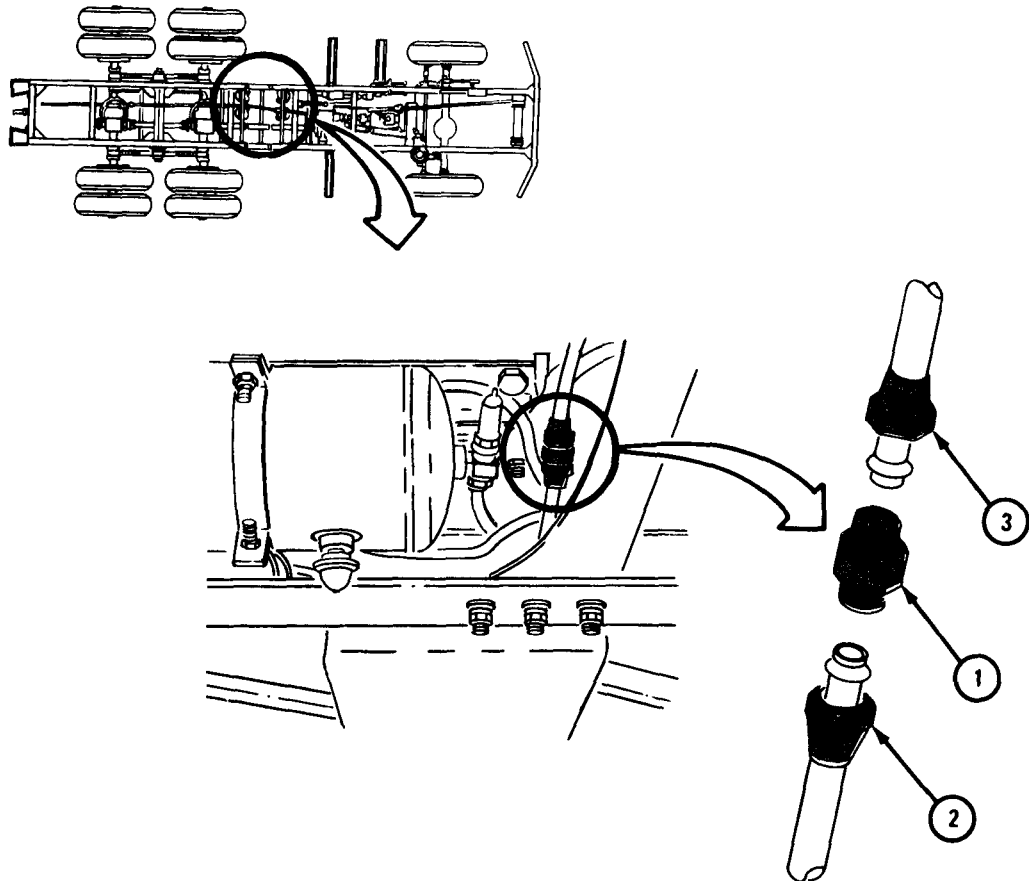

TA 083982

(b) Air tube junction tee fitting assembly

NOTE

The air tube junction tee fitting assembly on the air compressor governor is used for this typical procedure.

FRAME 1

1. Using 5/8-inch combination box and open end box wrench, unscrew and take off two tube nuts (1).
2. Using adjustable wrench, carefully unscrew and take out tee fitting (2).

END OF TASK

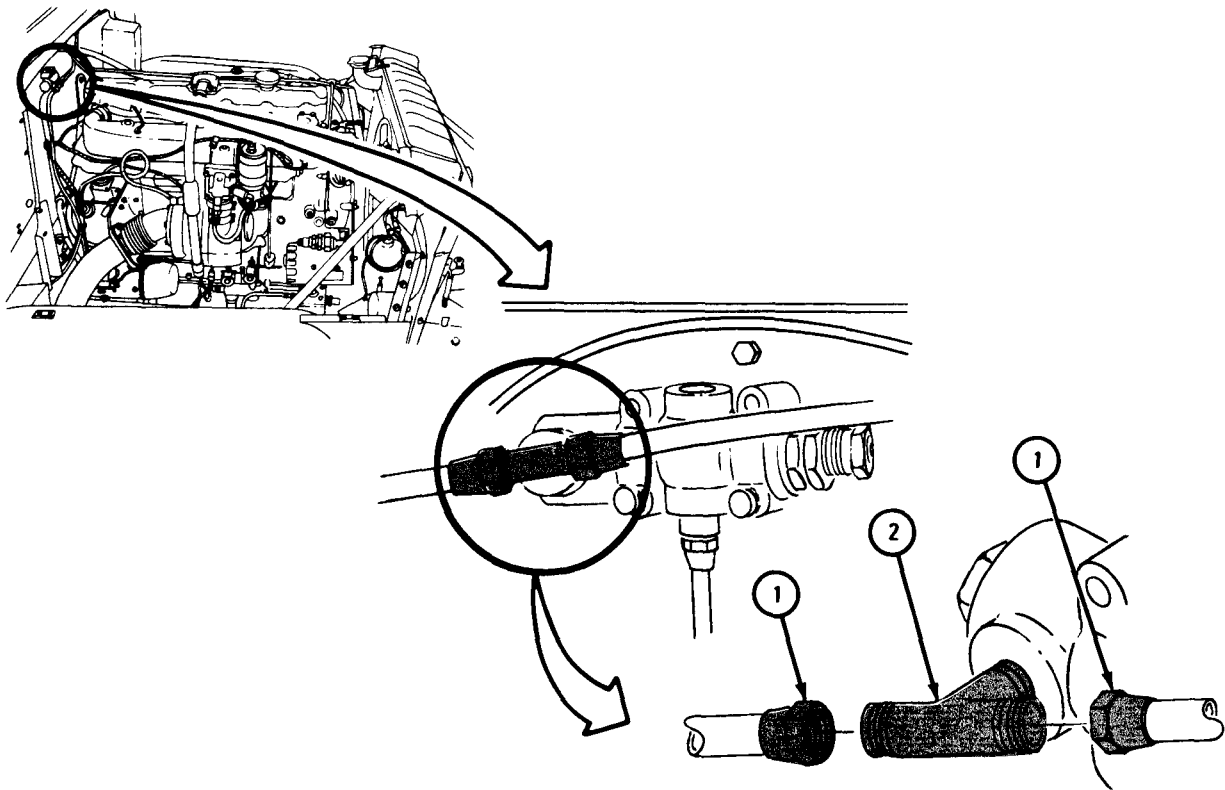

TA 083983

(c) Air tube elbow fitting

NOTE

The air tube elbow on the right side air tank on truck M764 is used for this typical procedure.

FRAME 1

1. Using 13/16-inch combination box and open end box wrench, unscrew and take off tube nut (1).
2. Using 3/4-inch combination box and open end box wrench, unscrew and take out elbow fitting (2).

END OF TASK

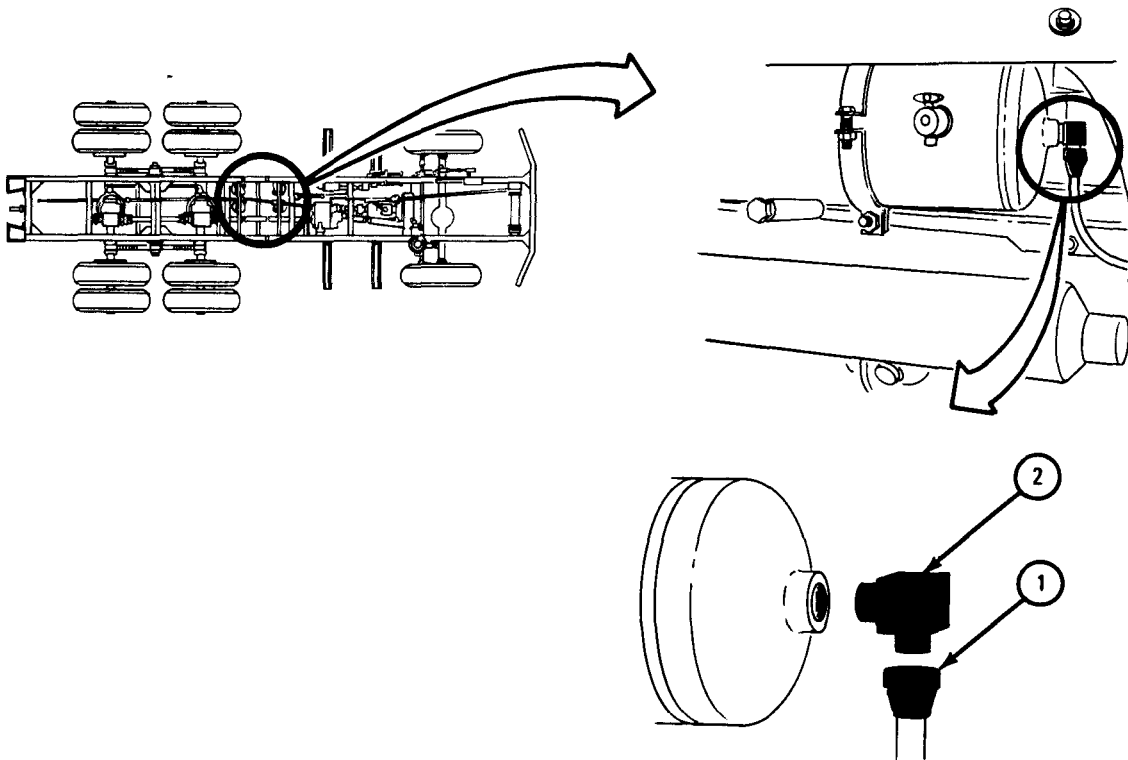

TA 083984

(d) Pipe plug

FRAME 1

NOTE

The pipe plug on the air supply valve is used for this typical procedure.

1. Using 3/8-inch combination box and open end box wrench, unscrew and take out pipe plug (1).

END OF TASK

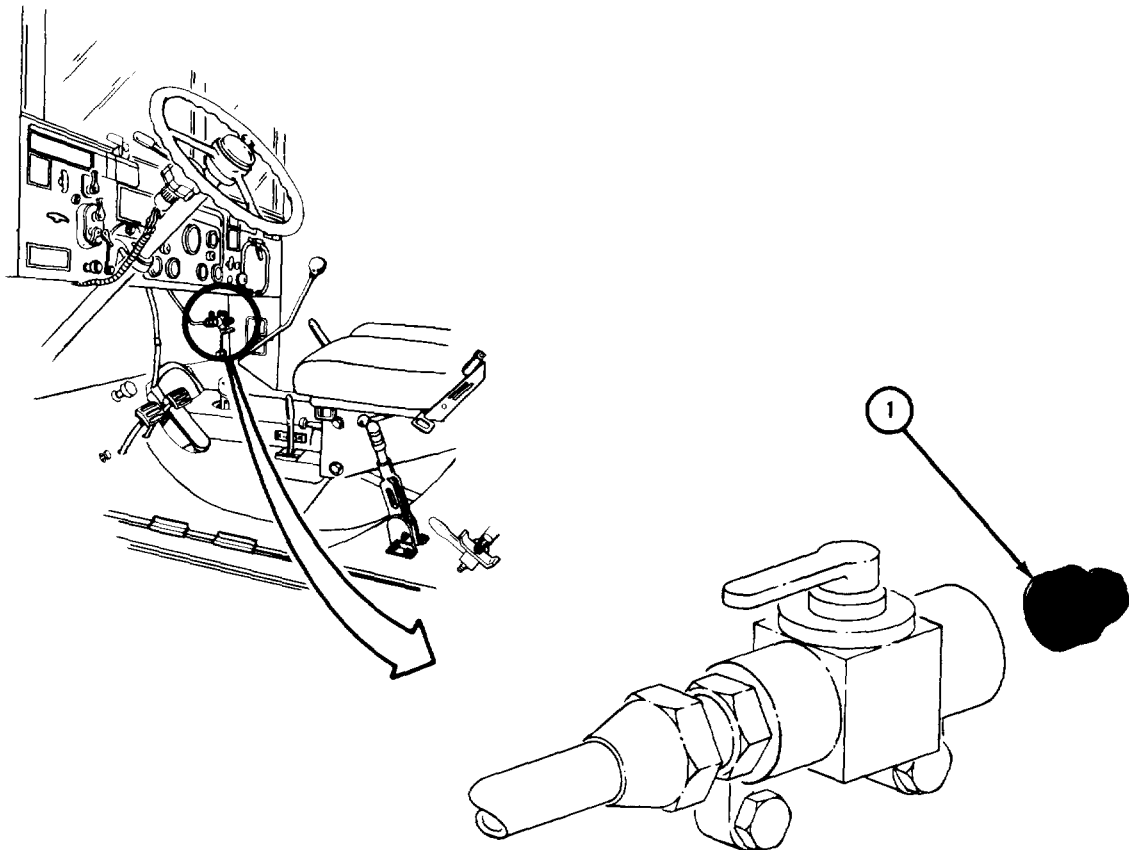

TA 083985

c. Replacement.

- (1) Air lines and clamps.

CAUTION

Fittings are made of soft brass. They can be stripped if tightened too much. Tighten fittings just enough to stop air from leaking.

NOTE

The air valve supply line at left rear of chassis on truck M275A2 is used for this typical task.

FRAME 1

1. Put air tube (1) in place as shown.
2. Using 3/4-inch combination box and open end box wrench, hold tee fitting (2).
3. Using 13/16-inch combination box and open end box wrench, screw on and tighten tube nut (3).
4. Using 7/8-inch combination box and open end box wrench, screw on and tighten tube nut (4).

GO TO FRAME 2

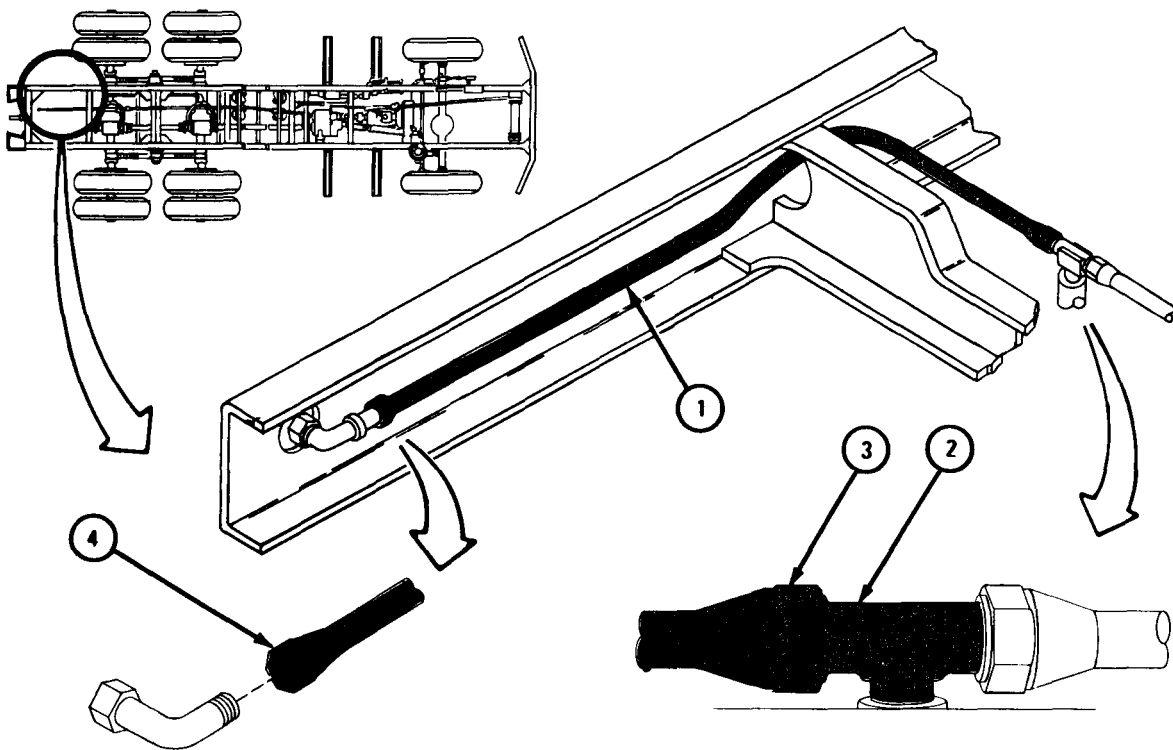

TA 083986

FRAME 2

1. Put tube clamp (1) on air tube (2).

NOTE

There may be an electrical harness clamp (3). If there is, put harness clamp on capscrew (4) before screwing on nut (5).

2. Using 9/16-inch wrench, put through and hold capscrew (4). Using 1/2-inch drive ratchet and 9/16-inch socket, screw on and tighten nut (5).
3. Do steps 1 and 2 again for other three tube clamps (1).

NOTE

Follow-on Maintenance Action Required:

1. Start engine and let it run until air pressure gage reads between 65 and 125 psi. Refer to TM 9-2320-209-10.
2. Stop engine. Refer to TM 9-2320-209-10.
3. Do air system leak test. Refer to Part 1, para 1-5.

END OF TASK

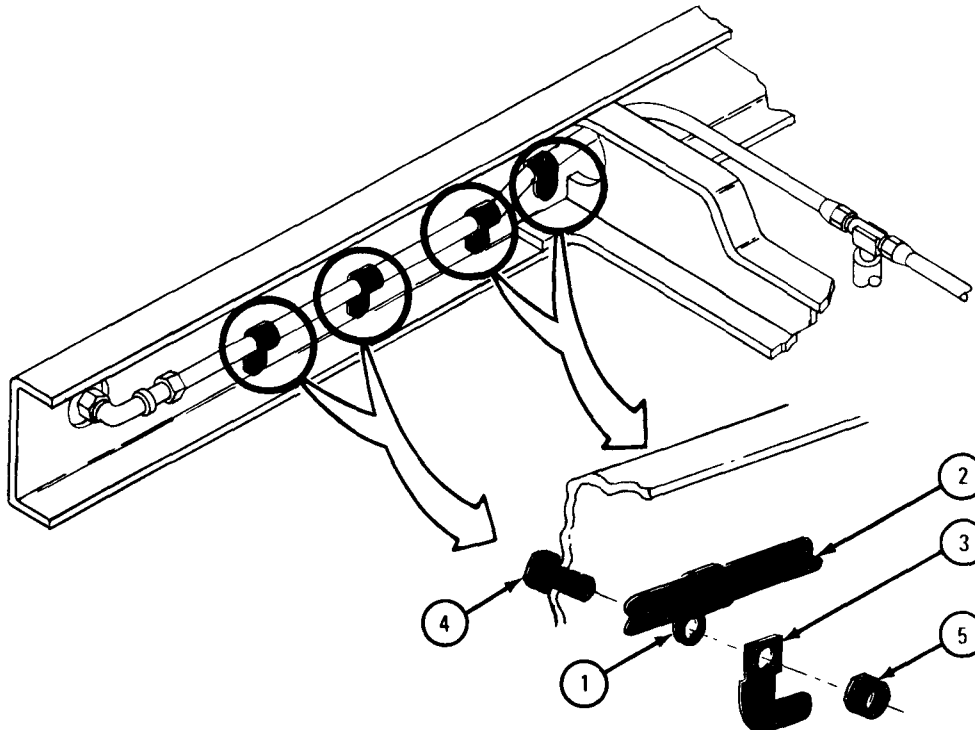

TA 083987

(2) Air tube fittings.

(a) Air tube connecting nipple

CAUTION

Fittings are made of soft brass. They can be stripped if tightened too much. Tighten fittings just enough to stop air from leaking.

NOTE

The air tube connecting nipple on the left side of chassis of truck M764 is used for this typical procedure.

FRAME 1

1. Screw two tube nuts (1) onto adapter fitting (2).
2. Using 11/16-inch combination box and open end box wrench, hold adapter fitting (2).
3. Using 13/16-inch combination box and open end box wrench, tighten two tube nuts (1).

NOTE

Follow-on Maintenance Action Required:

1. Start engine and let it run until air pressure gage reads between 65 and 125 psi. Refer to TM 9-2320-209-10.
2. Stop engine. Refer to TM 9-2320-209-10.
3. Do air system leak test. Refer to Part 1, para 1-5.

END OF TASK

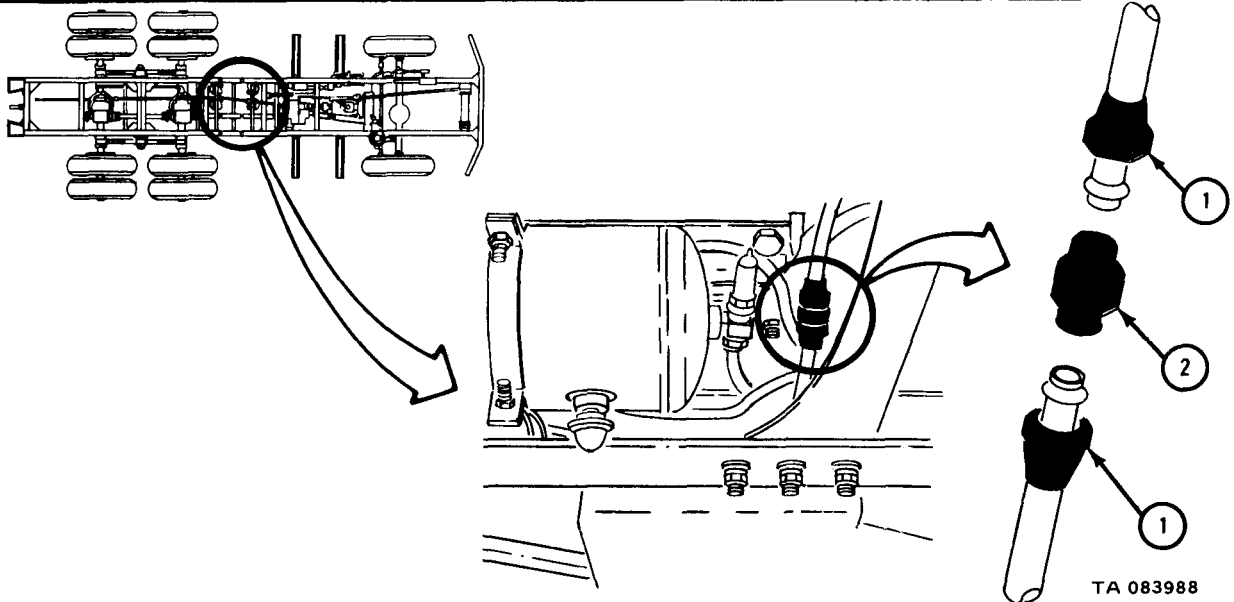

(b) Air tube junction tee fitting assembly

CAUTION

Fittings are made of soft brass. They can be stripped if tightened too much. Tighten fittings just enough to stop air from leaking.

NOTE

The air tube junction tee fitting assembly on the air compressor governor is used for this typical procedure.

FRAME 1

1. Using adjustable wrench, carefully screw in and tighten tee fitting (1).
2. Using 5/8-inch combination box and open end box wrench, screw on and tighten two tube nuts (2).

NOTE

Follow-on Maintenance Action Required:

1. Start engine and let it run until air pressure gage reads between 65 and 125 psi. Refer to TM 9-2320-209-10.
2. Stop engine. Refer to TM 9-2320-209-10.
3. Do air system leak test. Refer to Part 1, para 1-5.

END OF TASK

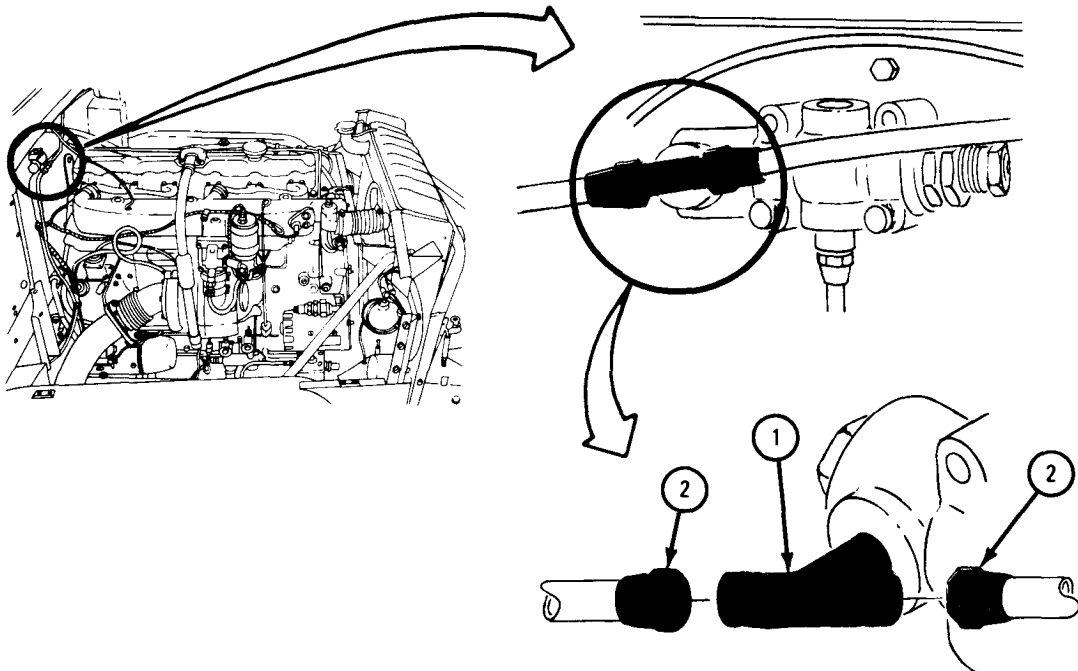

TA 083989

(c) Air tube elbow fitting

CAUTION

Fittings are made of soft brass. They can be stripped if tightened too much. Tighten fittings just enough to stop air from leaking.

NOTE

The air tube elbow on the right side air tank on truck M764 is used for this typical procedure.

FRAME 1

1. Using 3/4-inch combination box and open end box wrench, screw in and tighten elbow fitting (1).
2. Using 13/16-inch combination box and open end box wrench, screw on and tighten tube nut (2).

NOTE

Follow-on Maintenance Action Required:

1. Start engine and let it run until air pressure gage reads between 65 and 125 psi. Refer to TM 9-2320-209-10.
2. Stop engine. Refer to TM 9-2320-209-10.
3. Do air system leak test. Refer to Part 1, para 1-5.

END OF TASK

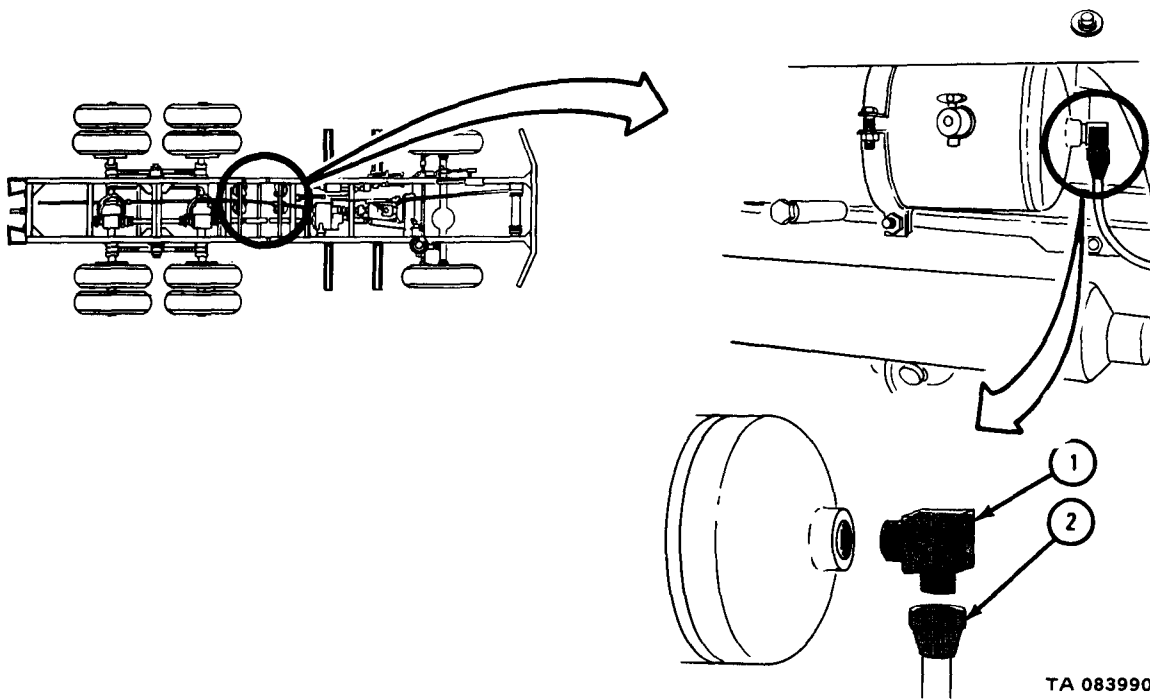

(d) Pipe plug

CAUTION

Fittings are made of soft brass. They can be stripped if tightened too much. Tighten fittings just enough to stop air from leaking.

NOTE

The pipe plug on the air supply valve is used for this typical procedure.

FRAME 1

1. Using 3/8-inch combination box and open end box wrench, screw in and tighten pipe plug (1).

NOTE

Follow-on Maintenance Action Required:

1. Start engine and let it run until air pressure gage reads between 65 and 125 psi. Refer to TM 9-2320-209-10.
2. Stop engine. Refer to TM 9-2320-209-10.
3. Do air system leak test. Refer to Part 1, para 1-5.

END OF TASK

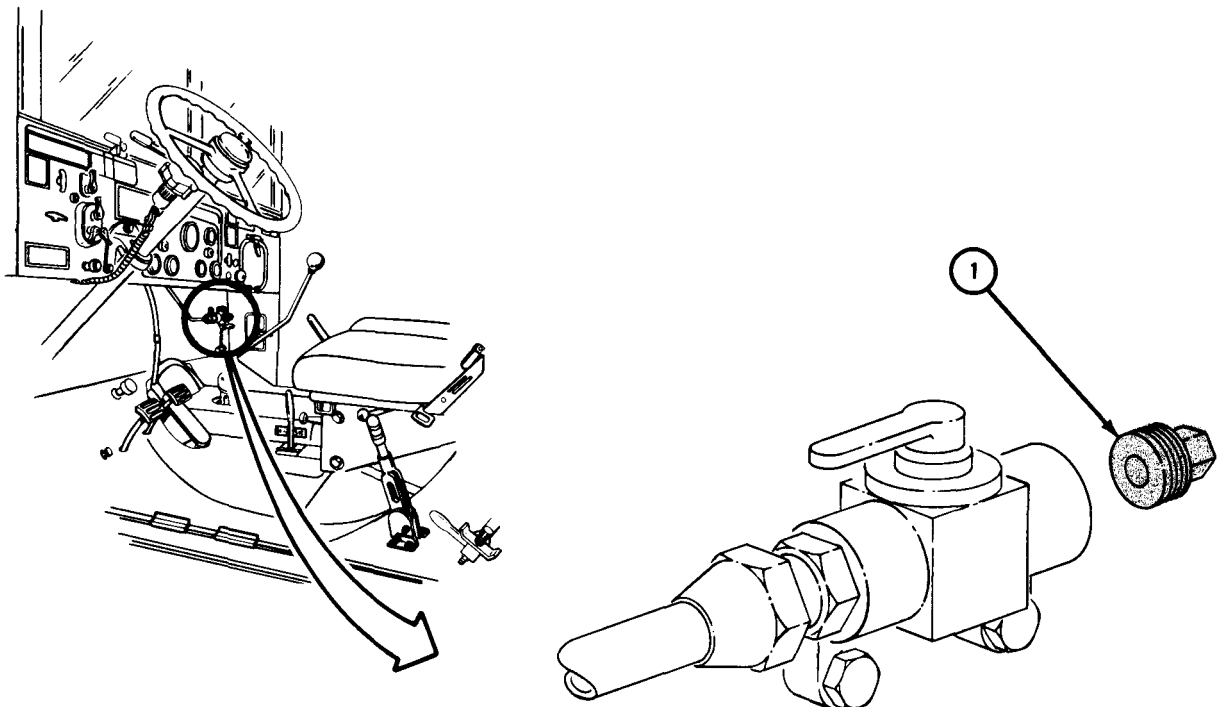

TA 083985

13-22. AIR BRAKE VALVE REMOVAL AND REPLACEMENT.

TOOLS: 1-inch wrench
7/8-inch wrench
1 1/4-inch wrench
15-inch adjustable wrench

SUPPLIES: None

PERSONNEL: One

EQUIPMENT CONDITION: Truck parked, engine off, handbrake set.

- a. Preliminary Procedure. Vent air system pressure. Refer to para 13-20.
- b. Removal.

FRAME 1

1. Turn valve handle (1) to the on (down) position.
 2. Using 1-inch wrench, unscrew coupling (2) and hose (3).
- GO TO FRAME 2

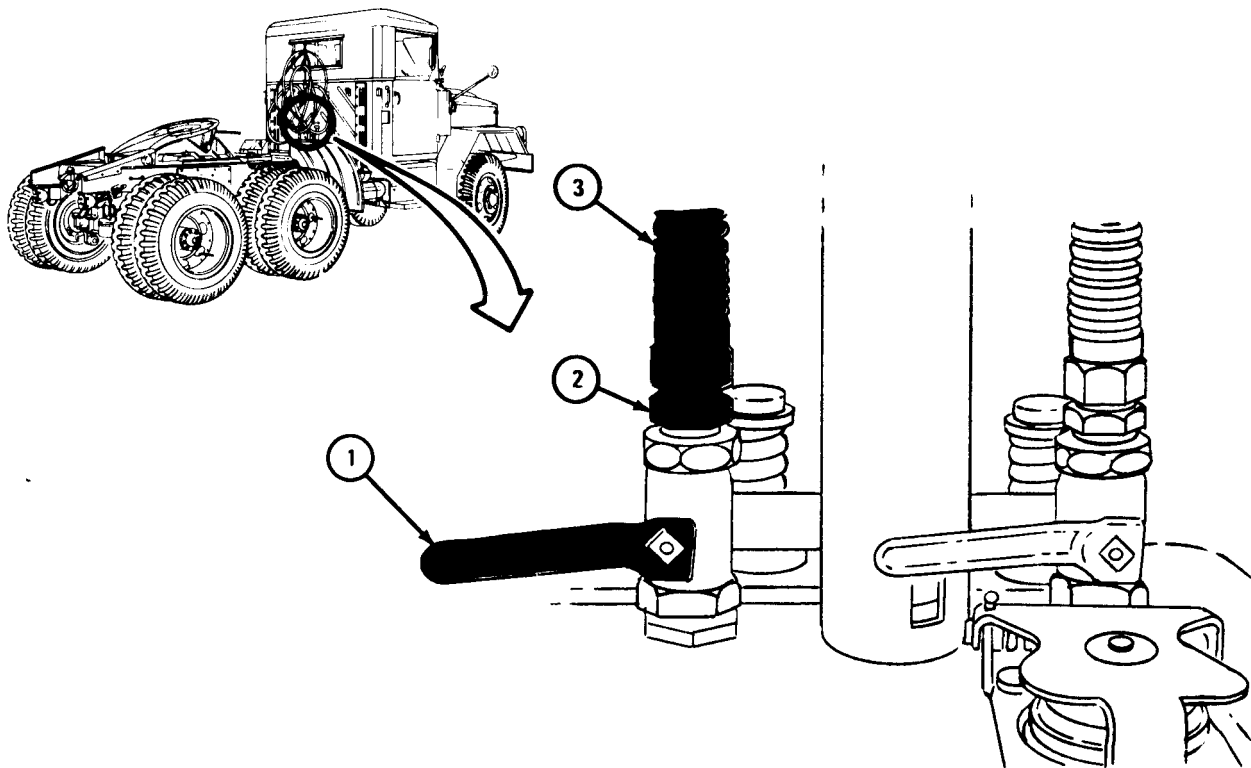

TA 046366

FRAME 2

1. Using adjustable wrench, hold valve (1). Using 7/8-inch wrench, unscrew and take off air line coupling (2).
2. Using adjustable wrench, take off nut (3) and take out valve (1).

END OF TASK

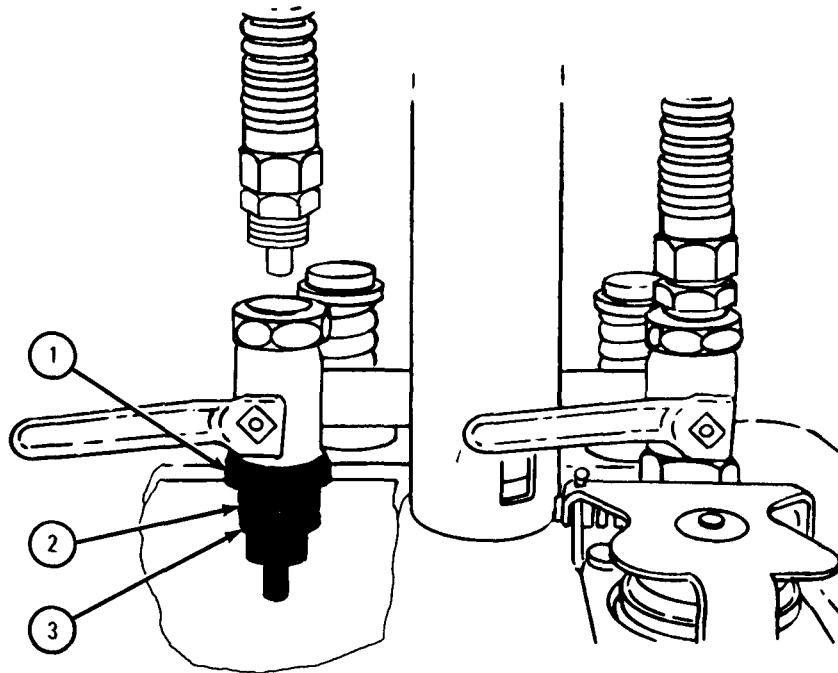

TA 046367

c . Replacement.

FRAME 1

1. Put valve (1) through hole and using adjustable wrench, put nut (2) on valve.
2. Using 7/8-inch wrench, screw in and tighten connecting nut (3) into valve (1).

GO TO FRAME 2

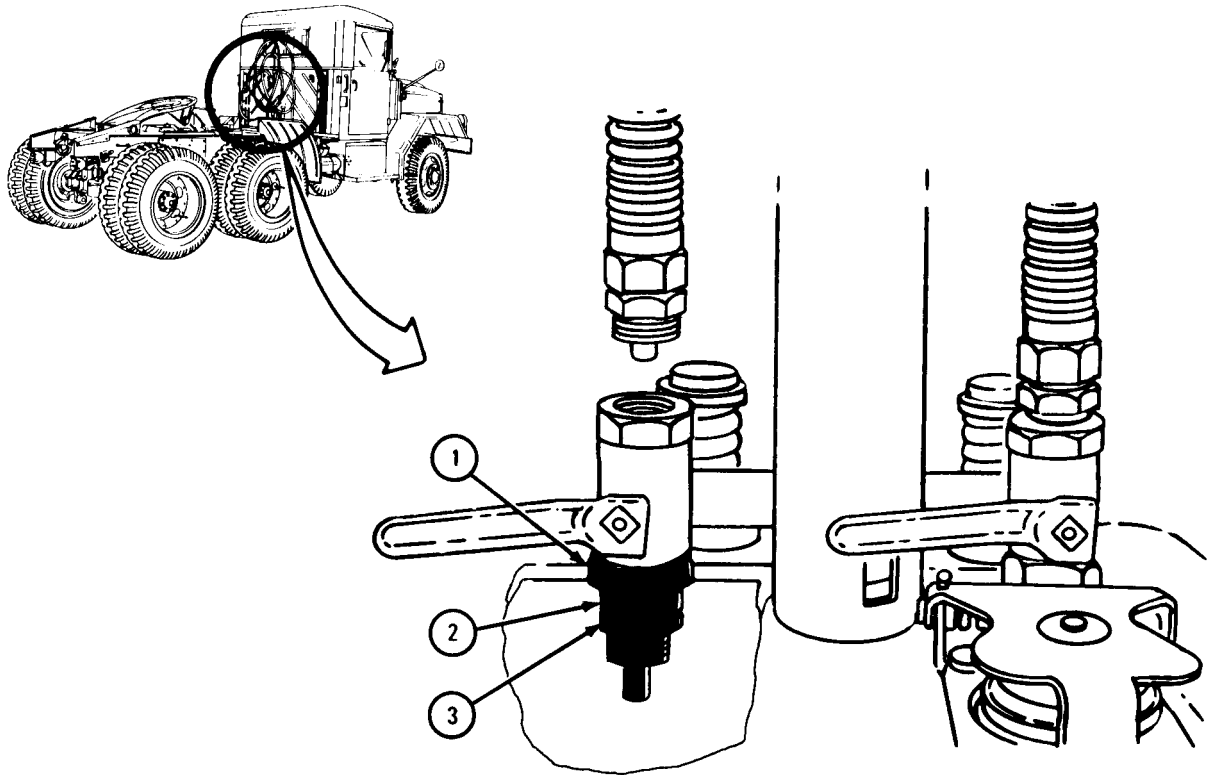

TA 046368

FRAME 2

1. Put hose (1) down onto valve (2) so coupling nut (3) can be screwed on.
2. Using adjustable wrench, hold valve (2). Using 1 1/16-inch wrench, screw on coupling nut (3).

END OF TASK

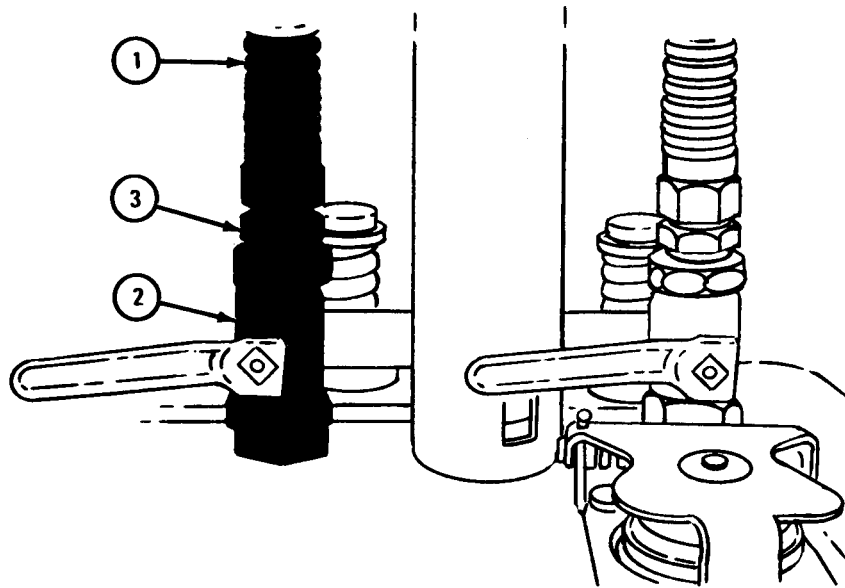

TA 046369

13-23. AIR BRAKE HAND CONTROL VALVE REPAIR.

NOTE

Repair of air brake hand control valve is limited to replacement of handle.

TOOLS: 5/16-inch sockethead screw key (Allen wrench or equivalent)
5/32-inch sockethead screw key (Allen wrench or equivalent)

SUPPLIES: None

PERSONNEL: One

EQUIPMENT CONDITION: Truck parked, engine off, handbrake set.

a. Removal.

FRAME 1

1. Turn handle (1) on drain cock (2) so handle lines up with drain cock. Do this to both reservoirs (3).

GO TO FRAME 2

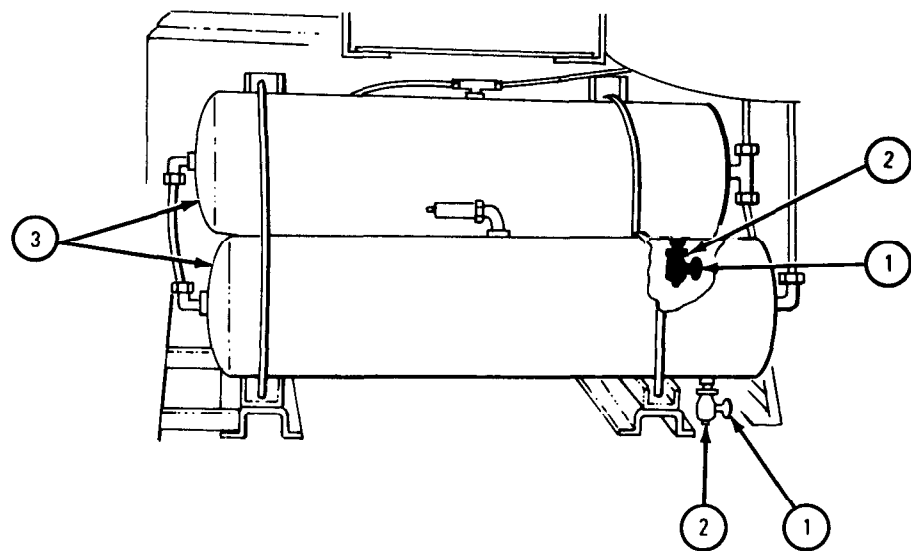
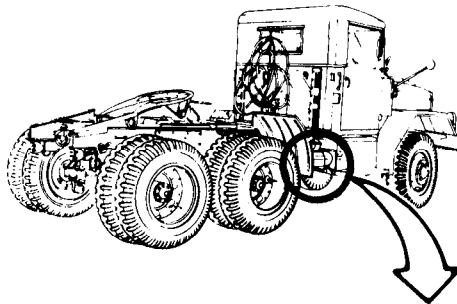

TA 046115

FRAME 2

1. Hold valve (1) so it does not fall. Using 5/16-inch allen wrench, unscrew and take out two screws (2) from mounting clamp (3). Take off two lockwashers (4) and mounting clamp (3).
2. Be careful not to put a kink in air lines (5). Swing valve (1) out and away from steering column (6) so setscrew (7) can be reached with 5/32-inch allen wrench.
3. Using 5/32-inch allen wrench, unscrew and take out setscrew (7) from handle (8). Lift handle off valve (1).

END OF TASK

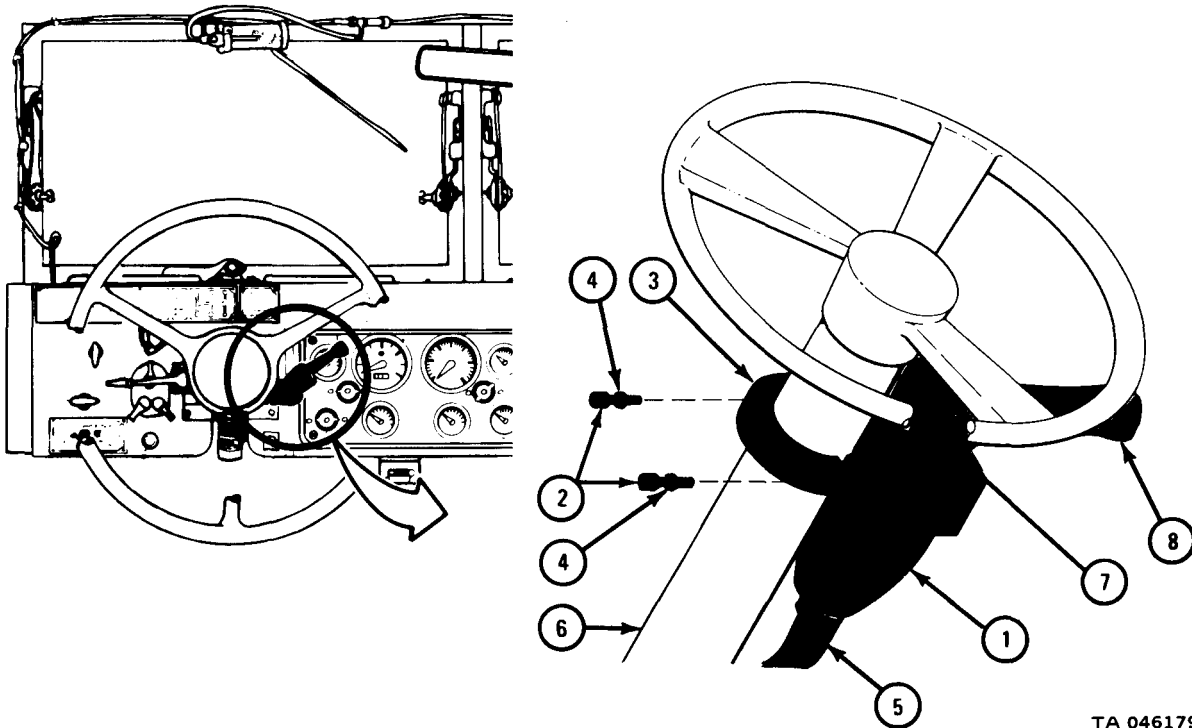

TA 046179

b. Replacement.

FRAME 1

1. Put handle (1) onto valve (2). Using 5/32-inch allen wrench, screw setscrew (3) into handle (1).
2. Pull valve (2) against steering column (4). Put mounting clamp (5) in place. Put lockwashers (6) onto two screws (7). Using 5/16-inch allen wrench, screw in and tighten screws through mounting clamp.

GO TO FRAME 2

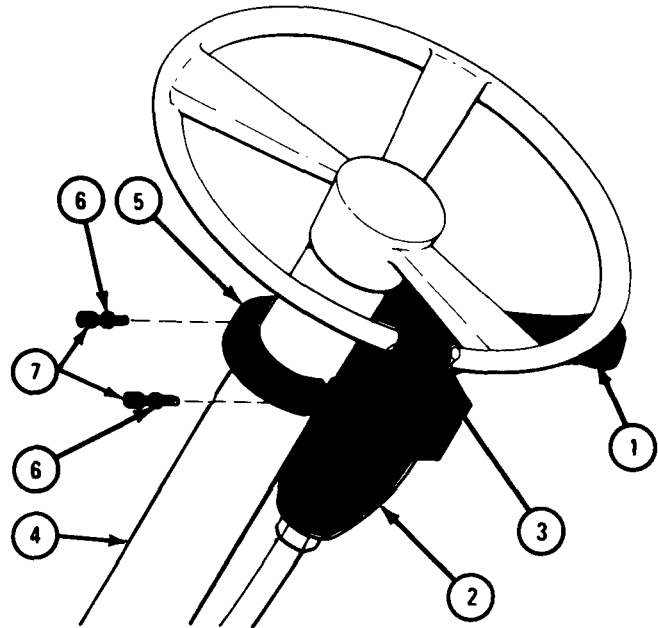
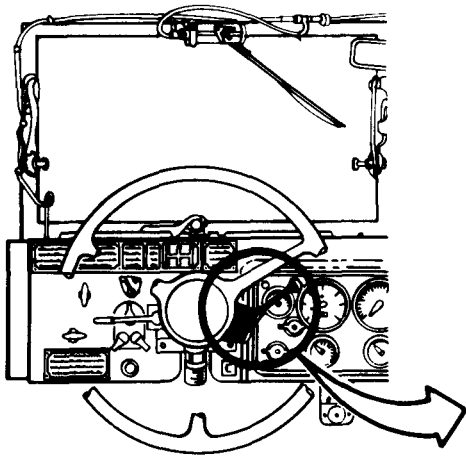

TA 046180

FRAME 2

1. Turn handle (1) on drain cock (2) so handle is across drain cock. Do this to both reservoirs (3).

END OF TASK

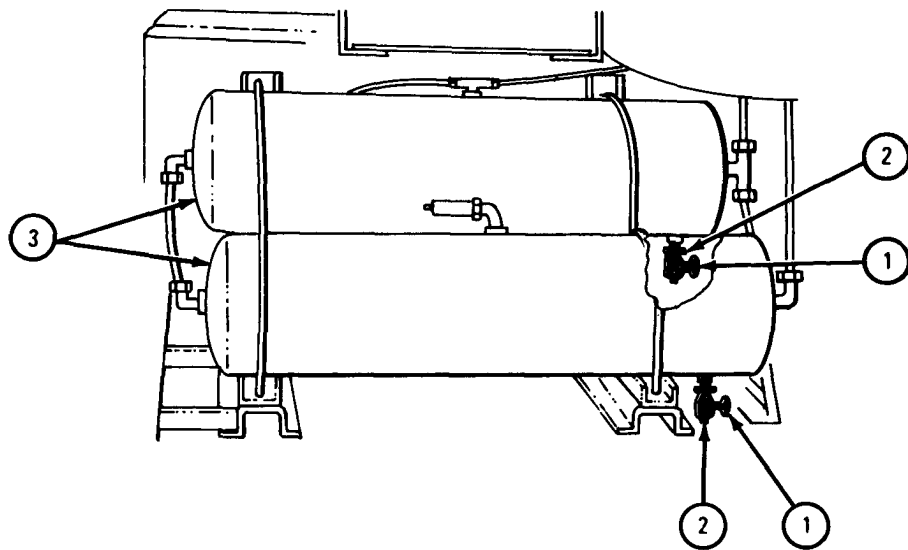
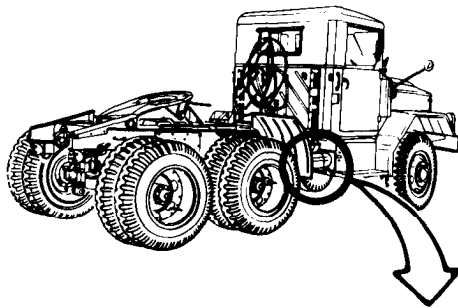

TA 046115

13-24. AIR BRAKE HAND CONTROL VALVE REMOVAL AND REPLACEMENT.

TOOLS: 5/8-inch open end wrench
9/16-inch open end wrench
5/16-inch sockethead screw key (Allen wrench or equivalent)

SUPPLIES: Chalk, SS-C-266F

PERSONNEL: One

EQUIPMENT CONDITION: Truck parked, engine off, handbrake set.

a. Removal.

FRAME 1

NOTE

When you take out a line or fitting, using chalk, mark it so that it goes back in same place.

1. Turn handle (1) on drain cock (2) so handle aligns with drain cock. Do this on both reservoirs (3).

GO TO FRAME 2

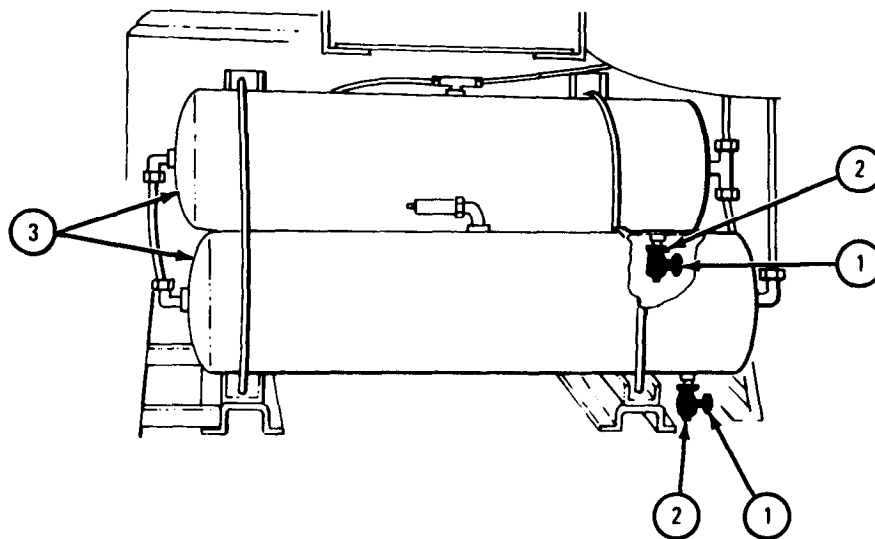
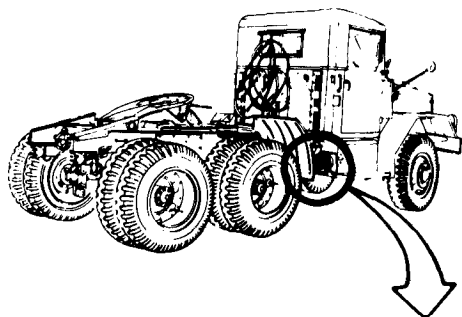

TA 101534

FRAME 2

1. Using 5/8-inch wrench, unscrew line nut (1) from adapter (2) and take off supply line (3).
2. Using 9/16-inch wrench, unscrew adapter (2) from valve (4).

GO TO FRAME 3

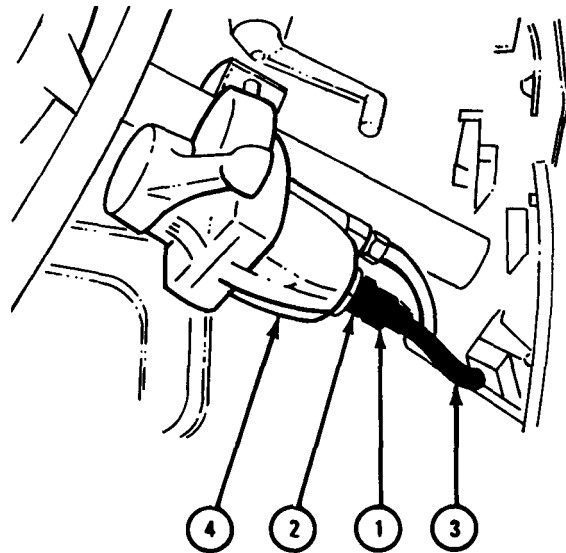
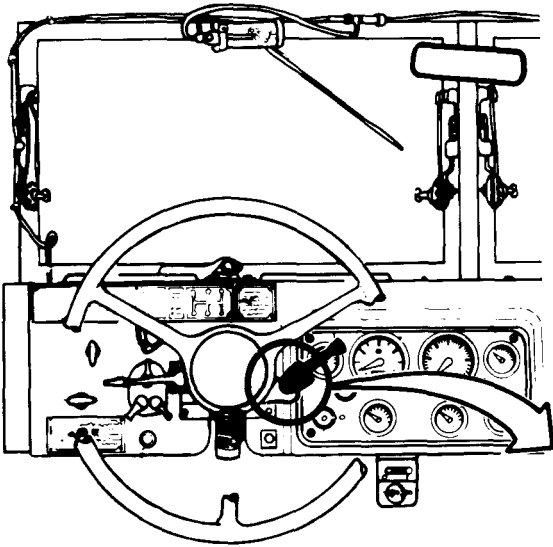

TA 046116

FRAME 3

1. Using 5/8-inch wrench, unscrew line nut (1) from adapter (2) and take off outlet line (3).
2. Using 9/16-inch wrench, unscrew adapter (2) from valve (4).

GO TO FRAME 4

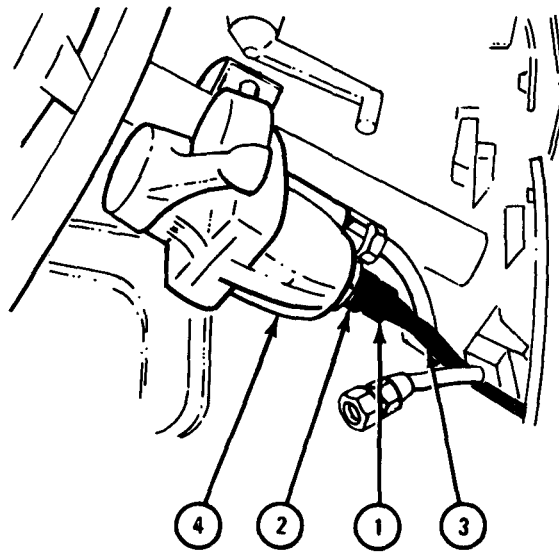

TA 046117

FRAME 4

1. Hold valve (1) so it does not fall. Using 5/16-inch allen wrench, unscrew and take out two screws (2) from mounting clamp (3). Take off two lockwashers (4).
2. Take off valve (1) and mounting clamp (3).

END OF TASK

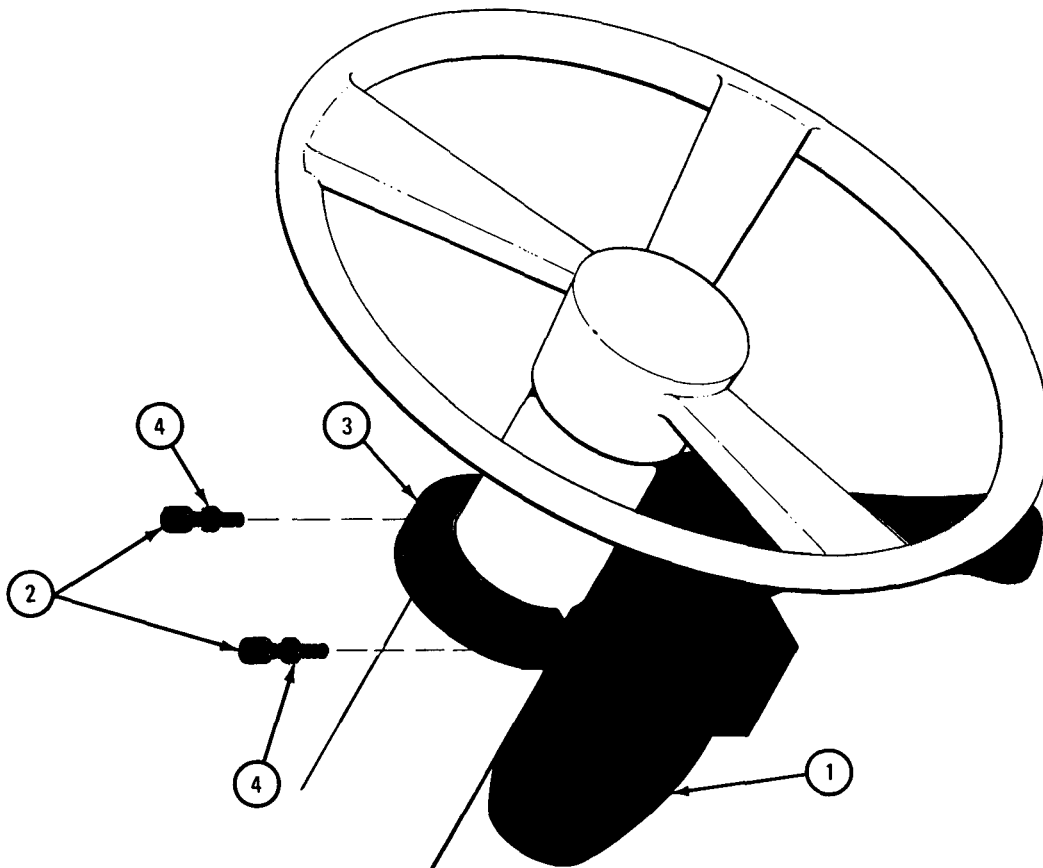

TA 046118

b. Replacement.

FRAME 1

1. Using 9/16-inch wrench, screw adapter (1) into valve (2).
 2. Using 9/16-inch wrench, screw adapter (3) into valve (2).
- GO TO FRAME 2

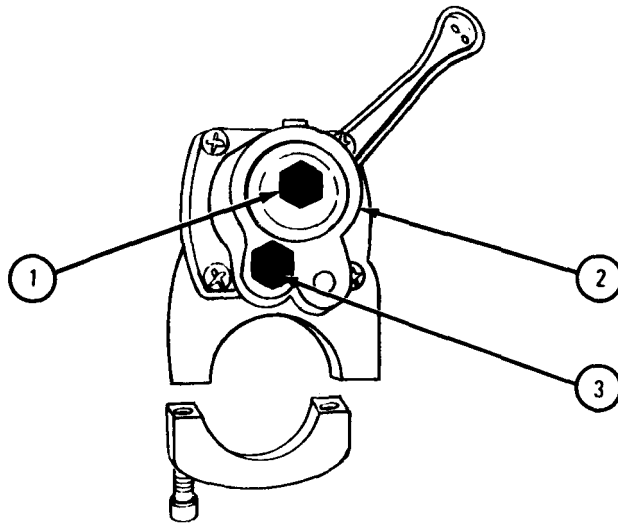

TA 046119

FRAME 2

1. Put valve (1) against right side of steering column (2) with handle (3) up. Put mounting clamp (4) in place as shown.
2. Put lockwashers (5) onto two screws (6).
3. Put two screws (6) in mounting clamp (4) and using 5/16-inch allen wrench, turn screws partway in.

NOTE

Screws (6) should be loose at this time so that valve (1) can be moved if needed.

GO TO FRAME 3

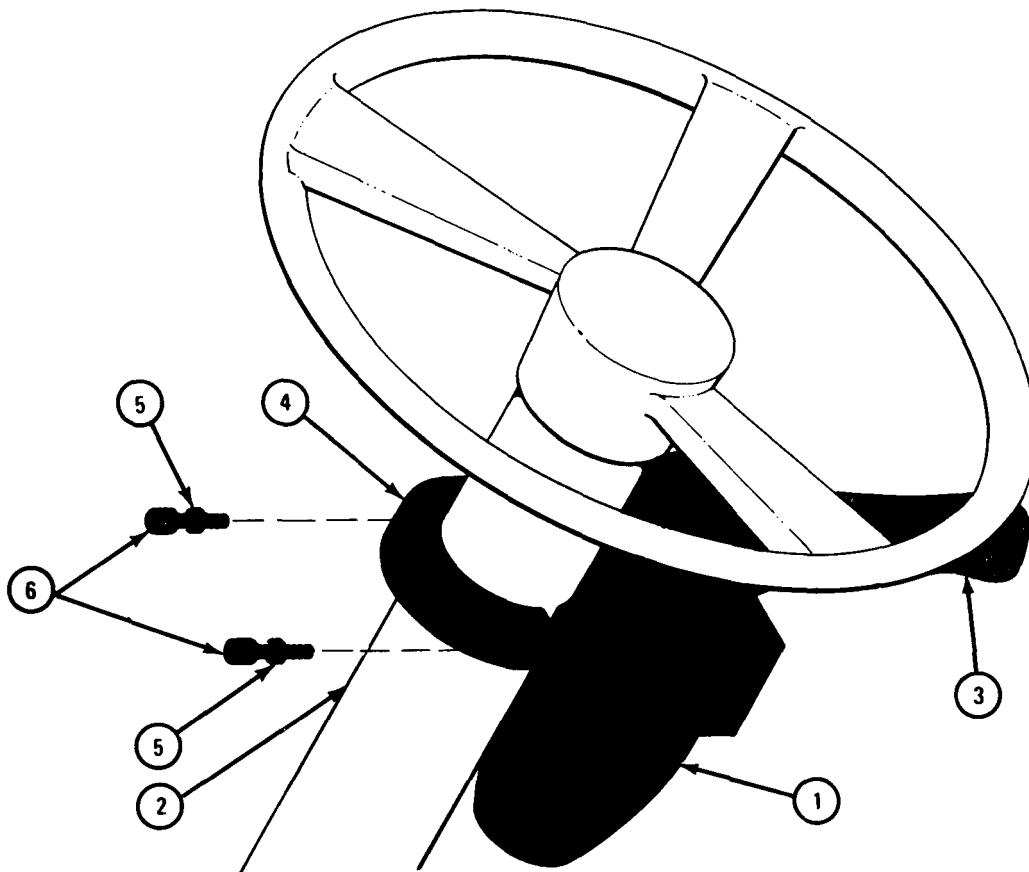

TA 046120

FRAME 3

CAUTION

Do not tighten coupling nuts too much. Screw coupling nuts on finger tight, then tighten nuts about 1/8 turn using 9/16-inch wrench.

1. Put outlet line (1) onto adapter (2). Screw on line nut (3).

GO TO FRAME 4

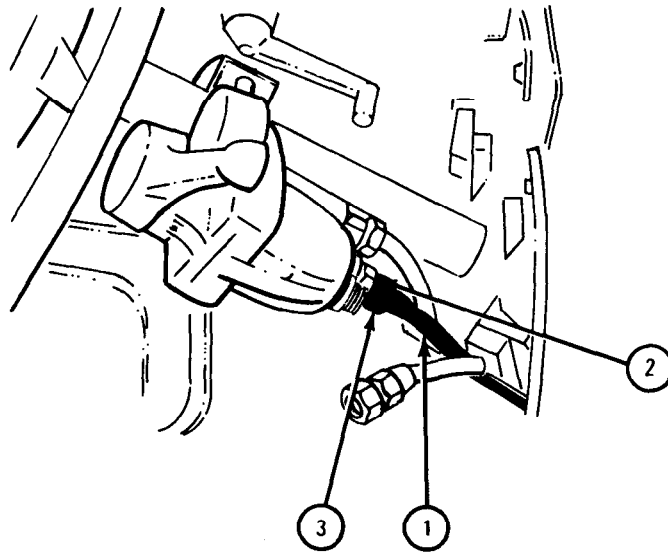

TA 046121

FRAME 4

1. Put supply line (1) into adapter (2). Screw on line nut (3).

GO TO FRAME 5

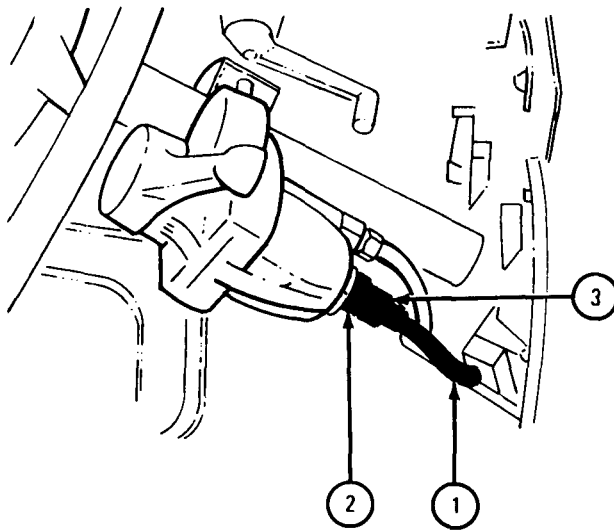

TA 101535

FRAME 5

1. Using 5/16-inch allen wrench, tighten two screws (1).

GO TO FRAME 6

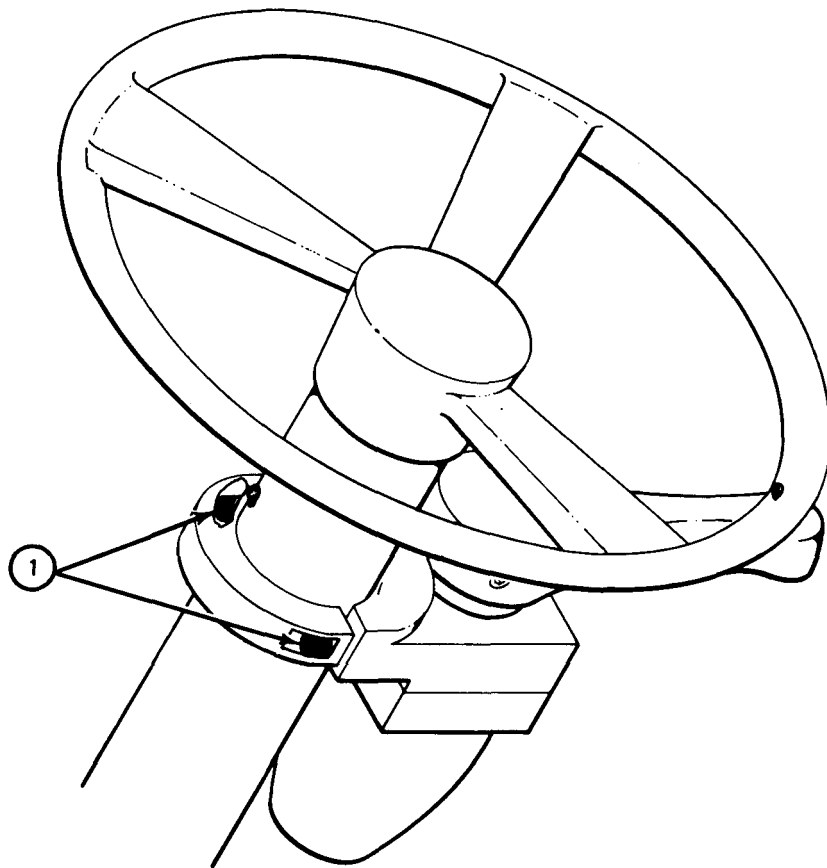

TA 046123

FRAME 6

1. Turn handle (1) on drain cock (2) so handle is across drain cock. Do this on both reservoirs (3).

END OF TASK

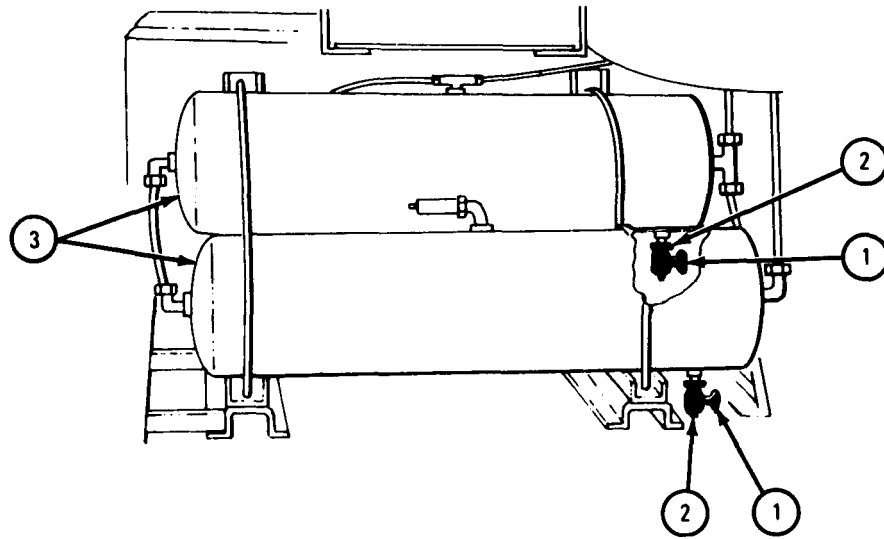
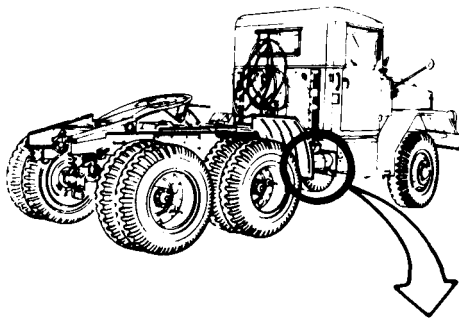

TA 101534

13-25. AIR SYSTEM SAFETY VALVE REMOVAL AND REPLACEMENT.

TOOLS: 3/4-inch open end wrench

SUPPLIES: None

PERSONNEL: One

EQUIPMENT CONDITION: Truck parked, engine off, handbrake set.

a. Preliminary Procedures.

(1) Vent air system pressure. Refer to para 13-20.

(2) If spare wheel blocks safety valve, remove spare wheel. Refer to TM 9-2320-209-10.

b . Removal.

FRAME 1

1. The air system safety valve (1) is located on trucks in different places, as shown.
2. Using wrench, unscrew and take off air system safety valve (1).

END OF TASK

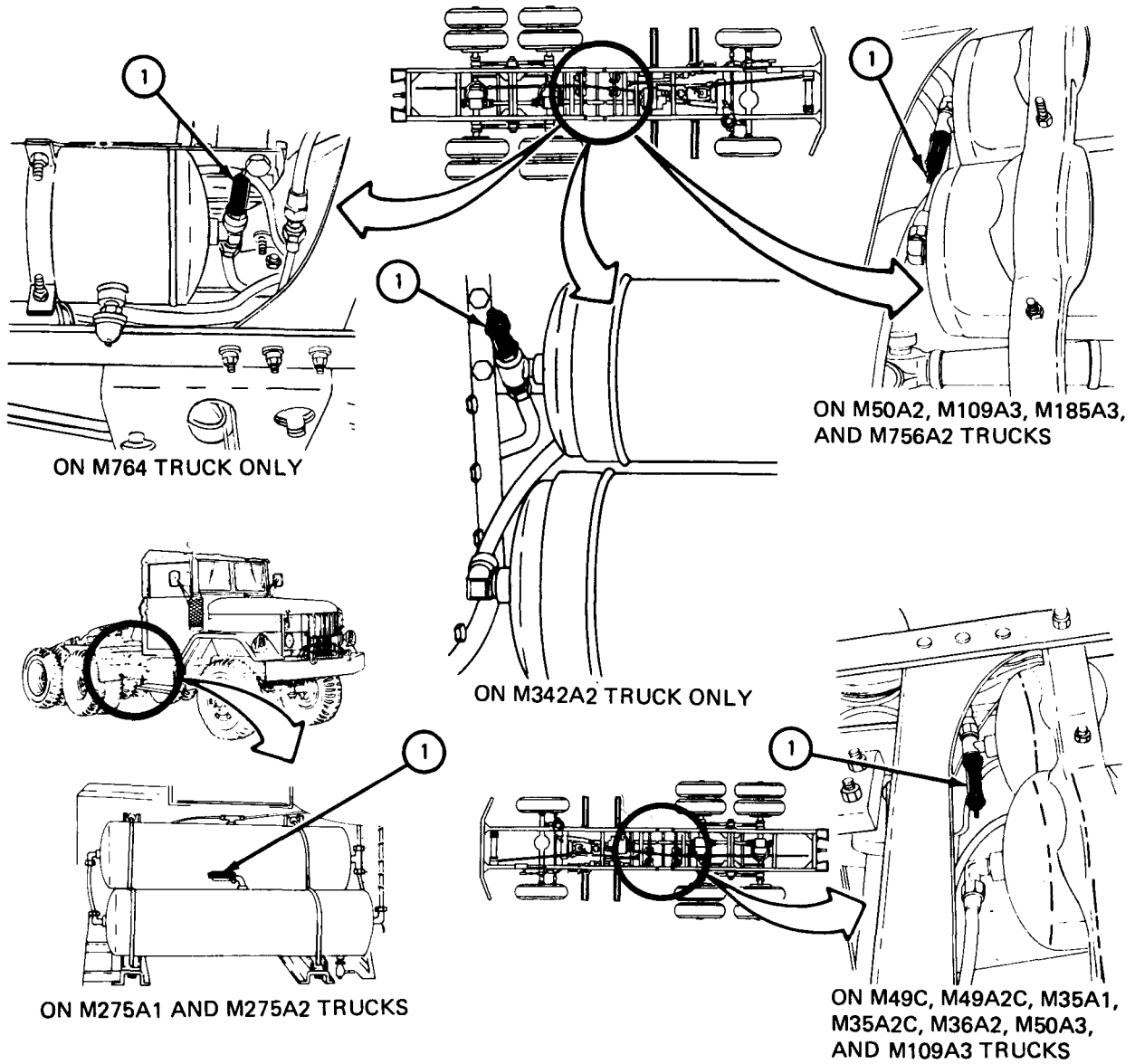

TA 046171

c. Replacement.

FRAME 1

1. The air system safety valve (1) is located on trucks in different places, as shown.
2. Using wrench, screw on and tighten air system safety valve (1).

NOTE

Follow-on Maintenance Action Required:

1. Do air system leak test. Refer to Part 1, para 1-5
2. If spare wheel was taken off, replace it. Refer to TM 9-2320-209-10.

END OF TASK

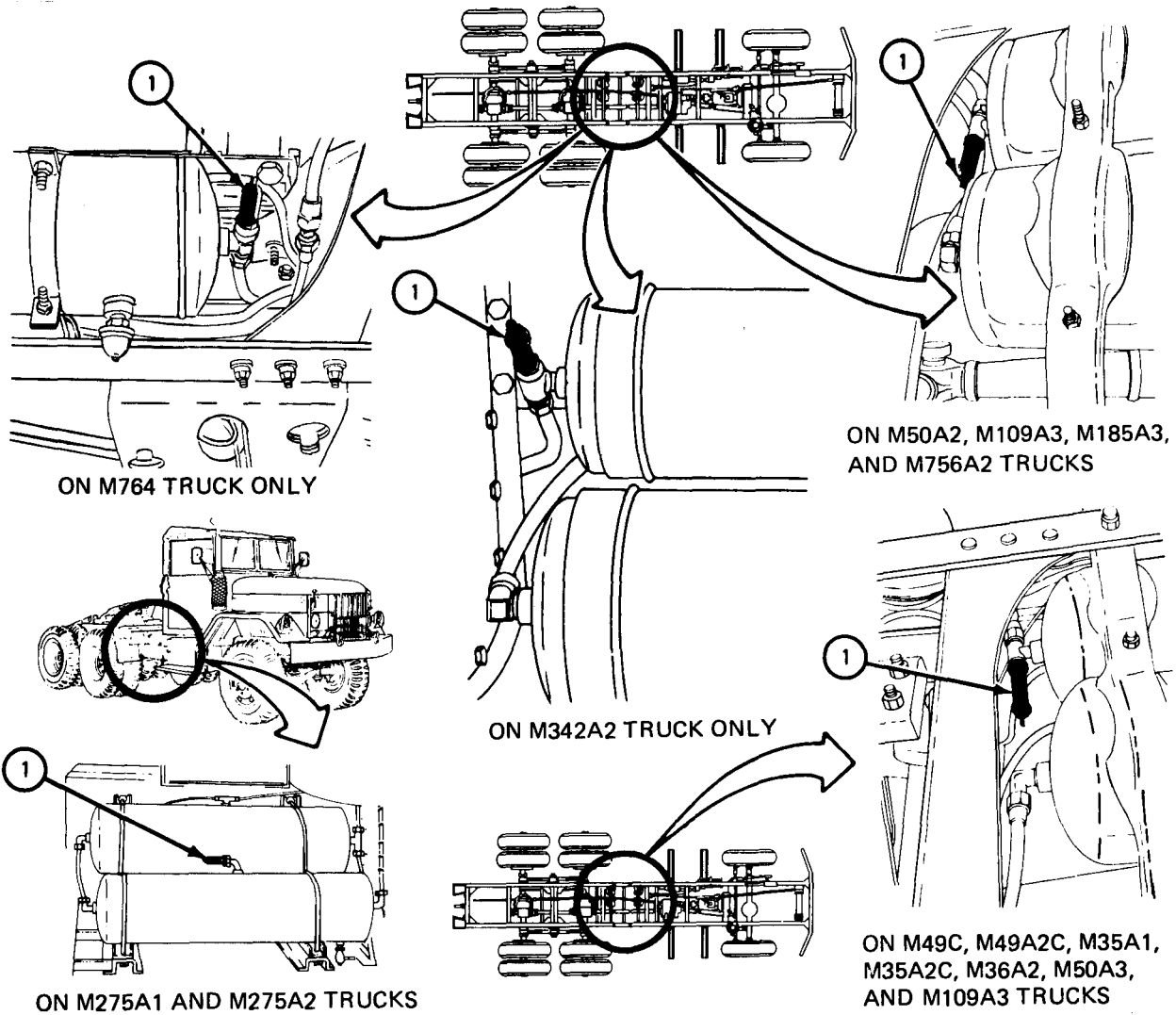

TA 046171

13-26. AIR RESERVOIRS REMOVAL AND REPLACEMENT (TRUCKS M275A1, M275A2, AND M342A2).

TOOLS: 13/16-inch wrench
5/8-inch wrench
7/16-inch socket wrench
3/4-inch wrench
6-inch pipe wrench

SUPPLIES: None

PERSONNEL: Two

EQUIPMENT CONDITION: Truck parked, engine off, handbrake set.

a. Preliminary Procedures.

(1) Vent air system pressure. Refer to para 13-20.

(2) If working on truck M342A2, remove muffler and rear exhaust pipe. Refer to Part 1, para 5-3.

(3) If working on truck M275A2, remove right rear splash guard. Tell direct support maintenance.

b. Removal.

FRAME 1

1. Using 5/8-inch wrench, unscrew and take off two coupling nuts (1).
2. Using 13/16-inch wrench, unscrew and take off two coupling nuts (2). Take off tube (3) with two coupling nuts.

GO TO FRAME 2

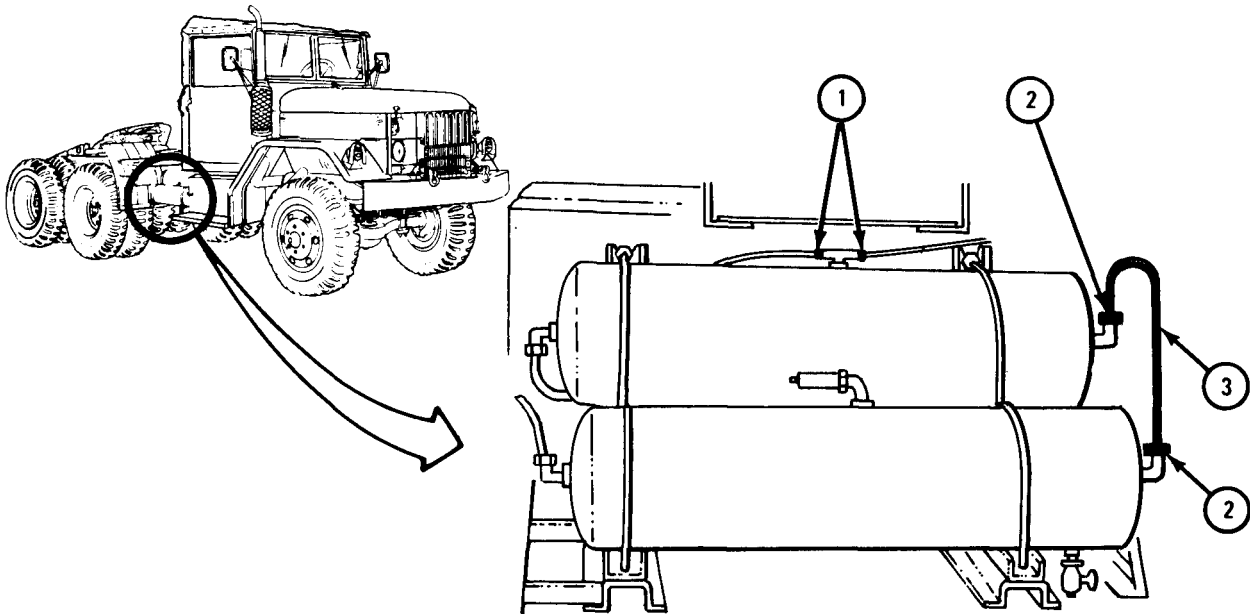

TA 046189

FRAME 2

1. Using 13/16-inch wrench, unscrew coupling nut (1) from elbow (2).
2. Using 13/16-inch wrench, unscrew coupling nut (3) from elbow (4).
3. Working from under truck and using 7/16-inch socket wrench, unscrew and take off four locknuts (5) and take off two U-bolts (6).
4. Take off lower air reservoir (7).

GO TO FRAME 3

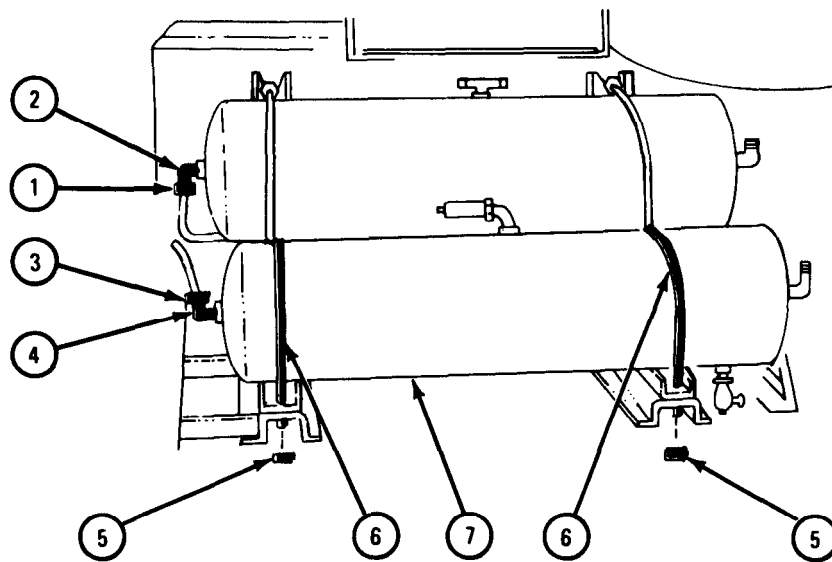

TA 046190

FRAME 3

- Soldier A 1. Hold upper air reservoir (1) in place.
- Soldier B 2. Working from behind upper air reservoir (1) and using 7/16-inch socket wrench, unscrew and take off four locknuts (2).
3. Take off two U-bolts (3).
- Soldier A 4. Take off upper air reservoir (1).
- GO TO FRAME 4

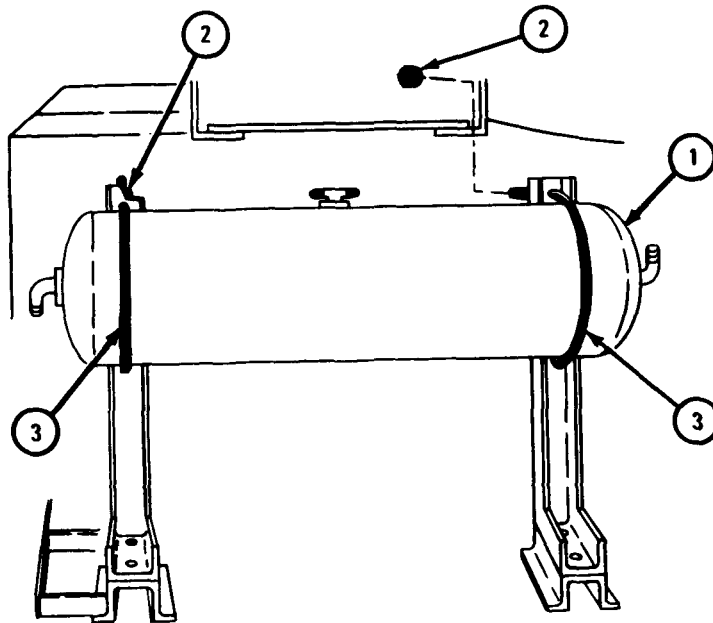

TA 080959

FRAME 4

NOTE

Note positions of fittings so that they are put back facing the same way.

1. Using 6-inch pipe wrench, unscrew and take off tee fitting (1) and two elbows (2) from upper air reservoir (3).
2. Using 3/4-inch wrench, unscrew and take off safety valve (4) and two elbows (5) from lower air reservoir (6).
3. Using 6-inch pipe wrench, unscrew and take off elbow (7) from lower air reservoir (6).
4. Using 5/8-inch wrench, unscrew and take off two drain cocks (8).

END OF TASK

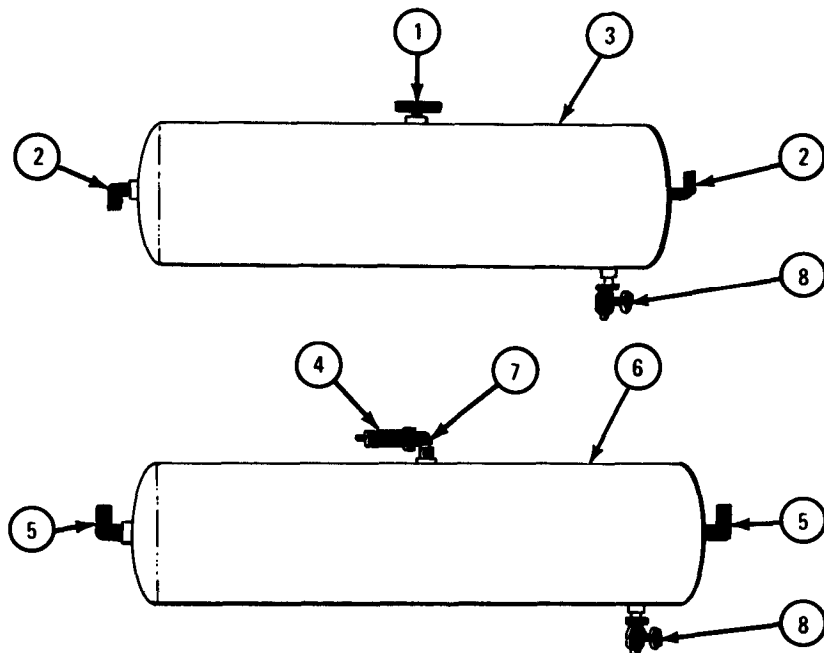

TA 046191

c. Replacement.

FRAME 1

1. Using 5/8-inch wrench, screw in and tighten two drain cocks (1).
2. Using 3/4-inch wrench, screw in and tighten two elbows (2) into lower air reservoir (3). Face elbows as noted.
3. Using 6-inch pipe wrench, screw in and tighten elbow (4) into lower air reservoir (3). Face elbow as noted.
4. Using 3/4-inch wrench, screw in and tighten safety valve (5) into elbow (4).
5. Using 3/4-inch wrench, screw in and tighten tee fitting (6) and two elbows (7) into upper air reservoir (8). Face elbows and tee fitting as noted.

GO TO FRAME 2

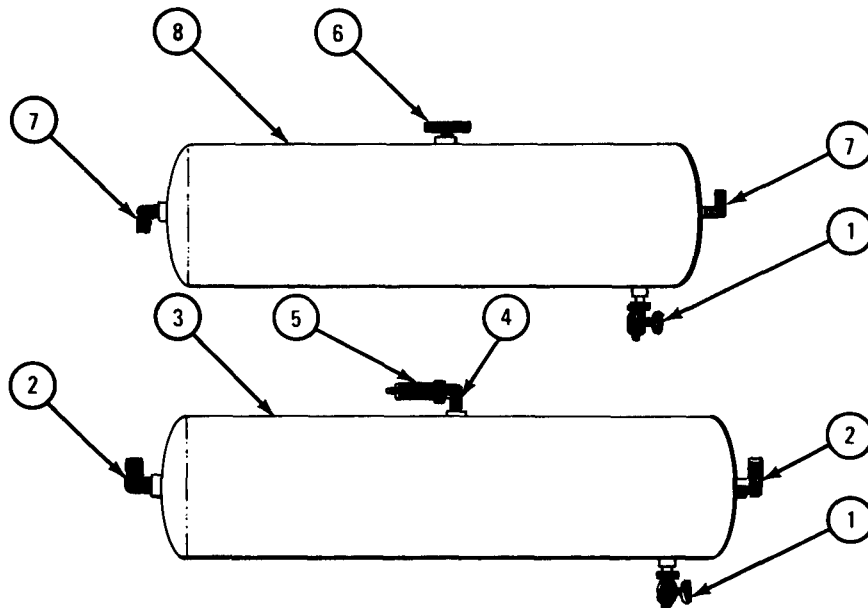

TA 046192

FRAME 2

- Soldier A 1. Put upper air reservoir (1) in place as shown and hold it there.
- Soldier B 2. Put two U-bolts (2) over air reservoir (1) as shown and through brackets (3).
3. Working from behind brackets (3) and using 7/16-inch socket wrench, screw on and tighten four locknuts (4).

GO TO FRAME 3

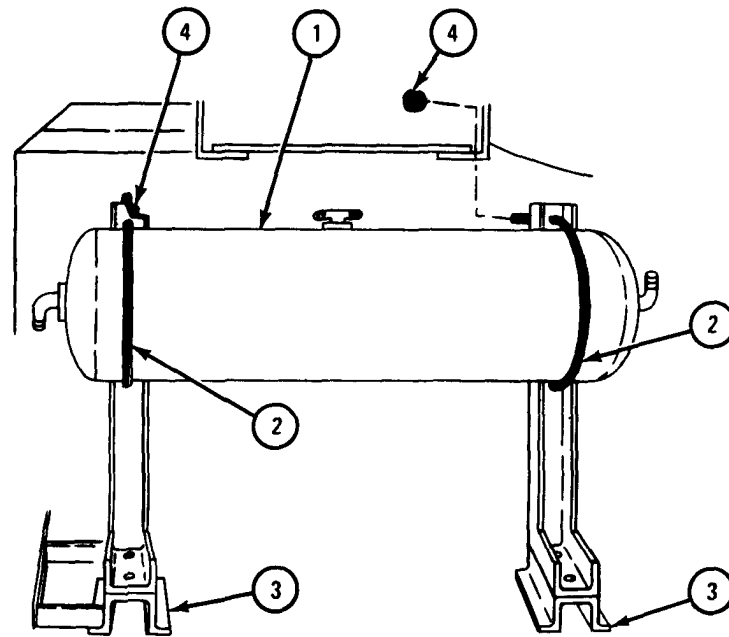

TA 080960

FRAME 3

CAUTION

Do not tighten coupling nuts too much. Screw on and finger tighten coupling nuts onto fittings, then using wrench, tighten nuts 1/8 turn.

1. Put lower air reservoir (1) in place as shown. Put two U-bolts (2) over air reservoir and through brackets (3).
2. Working from under bracket (3) and using 7/16-inch socket wrench, screw on and tighten four locknuts (4).
3. Using 13/16-inch wrench, screw on and tighten coupling nut (5) to elbow (6).
4. Using 13/16-inch wrench, screw on and tighten coupling nut (7) to elbow (8).

GO TO FRAME 4

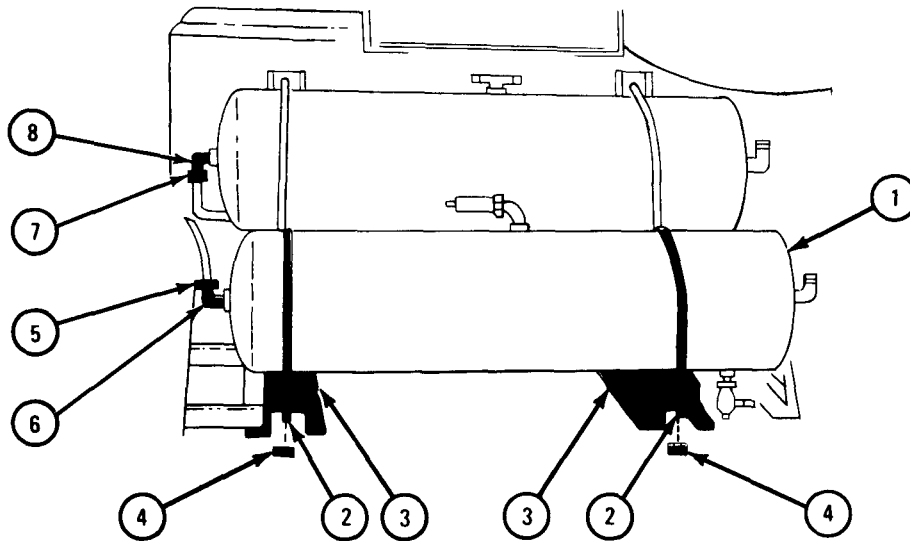

TA 046193

FRAME 4

CAUTION

Do not tighten coupling nuts too much. Screw on and finger tighten coupling nuts onto fittings, then using wrench, tighten nuts 1/8 turn.

1. Put tube (1) between two elbows (2) as shown.
2. Using 13/16-inch wrench, screw on and tighten two coupling nuts (3).
3. Using 5/8-inch wrench, screw on and tighten two coupling nuts (4) on tee fitting (5).

NOTE

Follow-on Maintenance Action Required:

1. Start engine and let air pressure build. Refer to TM 9-2320-209-10.
2. Do leak test of air system. Refer to Part 1, para 1-5.
3. If working on truck M275A2, replace right rear splash guard. Tell direct support maintenance.
4. If working on truck M342A2, replace muffler and rear exhaust pipe. Refer to Part 1, para 5-3.

END OF TASK

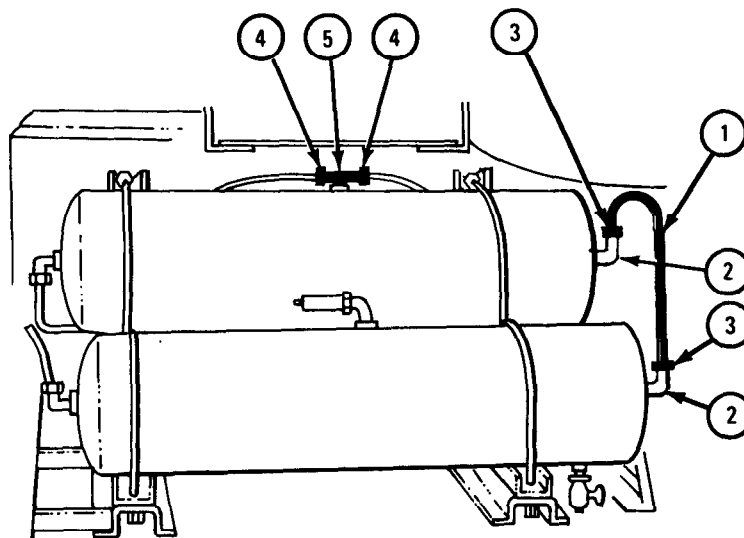

TA 046194

13-27. AIR RESERVOIRS REMOVAL AND REPLACEMENT (TRUCKS M49A1C AND M49A2C).

TOOLS: 13/16-inch wrench 9/16-inch wrench
 5/8-inch wrench 9/16-inch socket wrench, 3/8-inch drive
 9/16-inch wrench (2) 3/8-inch drive hinged handle
 3/4-inch wrench 15-inch adjustable wrench
 7/8-inch wrench

SUPPLIES: Anti-seize tape, MIL-T-27730A

PERSONNEL: TWO

EQUIPMENT CONDITION: Truck parked, engine off, handbrake set.

a. Preliminary Procedures.

- (1) Vent air system pressure. Refer to para 13-20.
- (2) Remove spare wheel. Refer to TM 9-2320-209-10.
- (3) Remove delivery pump drive shaft. Refer to Part 3, para 18-59.

b. Removal.

FRAME 1

1. Using 13/16-inch wrench, unscrew two coupling nuts (1).
 2. Take off tube (2) with two coupling nuts (1).
- GO TO FRAME 2

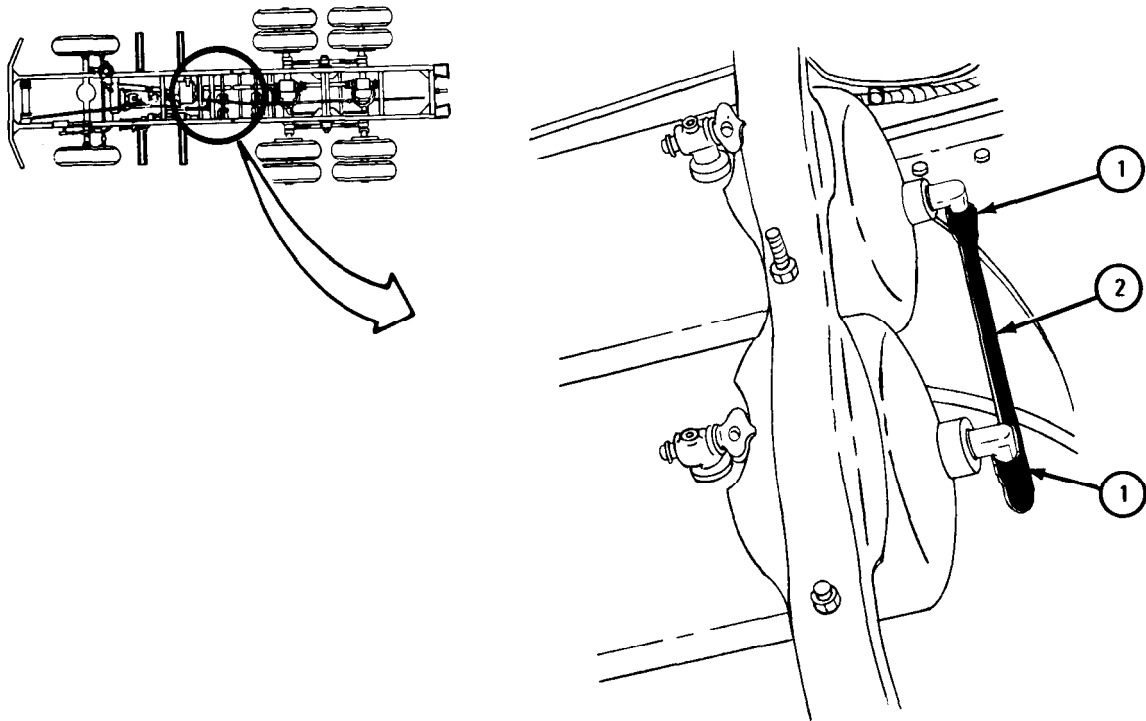

TA 080985

FRAME 2

1. Using 9/16-inch socket and hinged handle, hold two capscrews (1). Using 9/16-inch wrench, unscrew and take off two locknuts (2). Take out two cap screws.
2. Using 9/16-inch socket and hinged handle, hold capscrew (3). Using 9/16-inch wrench, unscrew and take off locknut (4). Take out capscrew.
3. Take off retaining strap (5).

GO TO FRAME 3

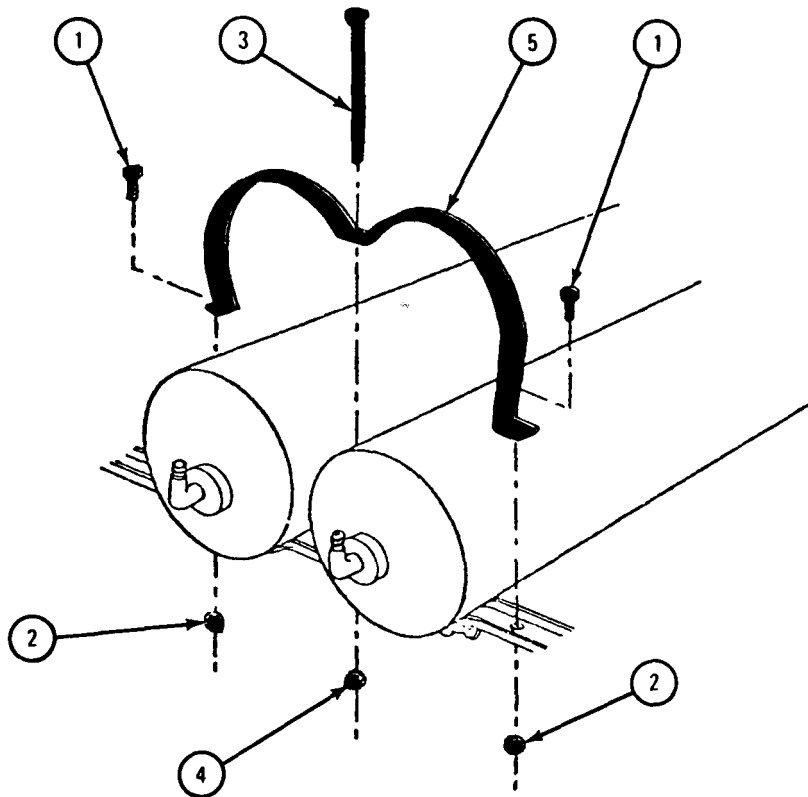

TA 080986

FRAME 3

1. Using 9/16-inch socket and hinged handle, hold two capscrews (1). Using 9/16-inch wrench, unscrew and take off two locknuts (2). Take out two capscrews.
2. Using 9/16-inch socket and hinged handle, hold capscrew (3). Using 9/16-inch wrench, unscrew and take off locknut (4). Take out capscrew.

GO TO FRAME 4

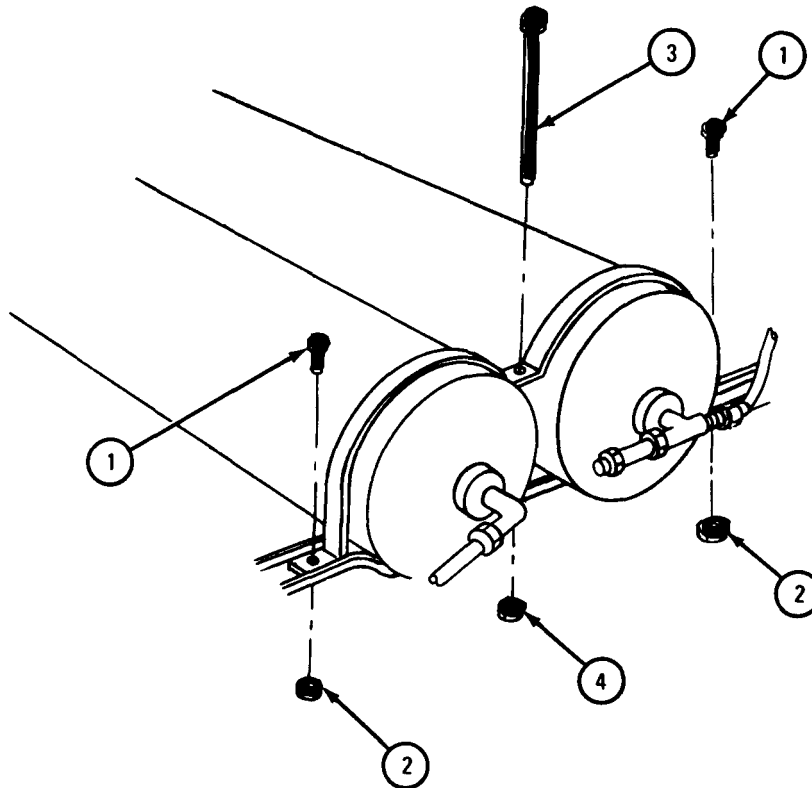

TA 101735

FRAME 4

1. Slide two air reservoirs (1) one inch toward rear of truck.
2. Working at front of air reservoirs (1) and using 13/16-inch wrench, unscrew coupling nut (2).
3. Using 7/8-inch wrench, unscrew coupling nut (3).

GO TO FRAME 5

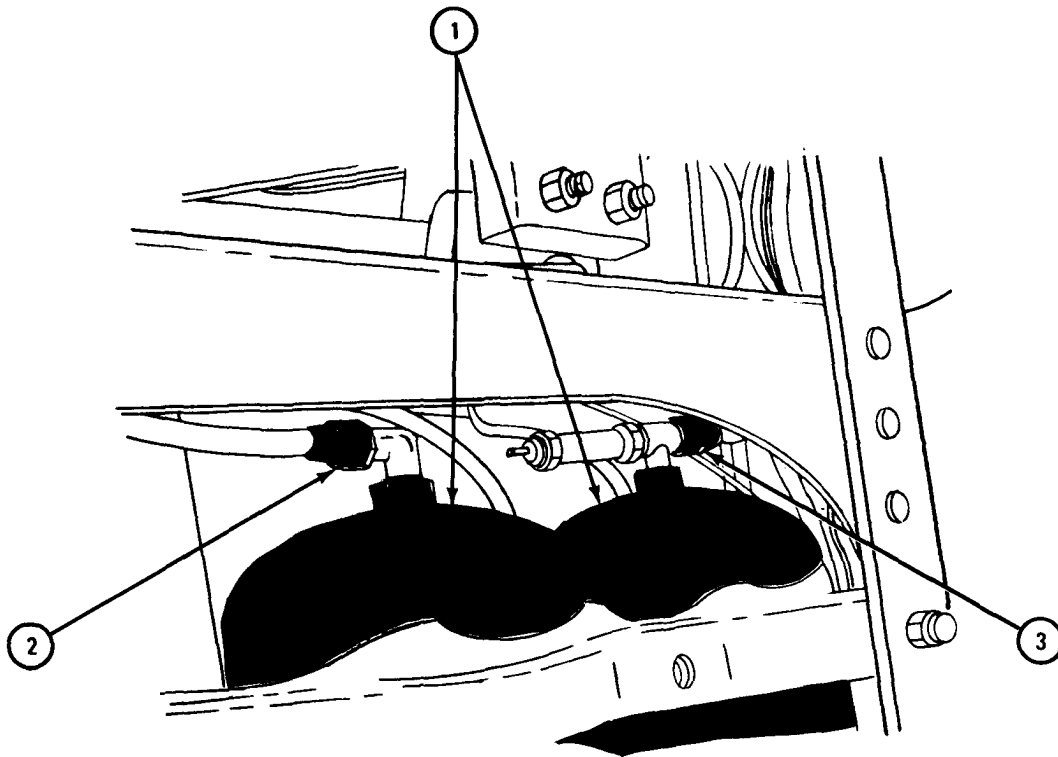

TA 080987

FRAME 5

- Soldiers A and B
1. Working at rear of air reservoirs (1 and 2), slide air reservoir (1) toward front of truck until it moves off rear support (3).
 2. Pull air reservoir (1) down under rear support (3) and slide it off front support (4). Take air reservoir out from under truck.
 3. Take off retaining strap (5).

- Soldier A
4. Using 5/8-inch wrench, unscrew two coupling nuts (6). Take off two tubes (7).

- Soldiers A and B
5. Do steps 1 and 2 again to take out air reservoir (2).

GO TO FRAME 6

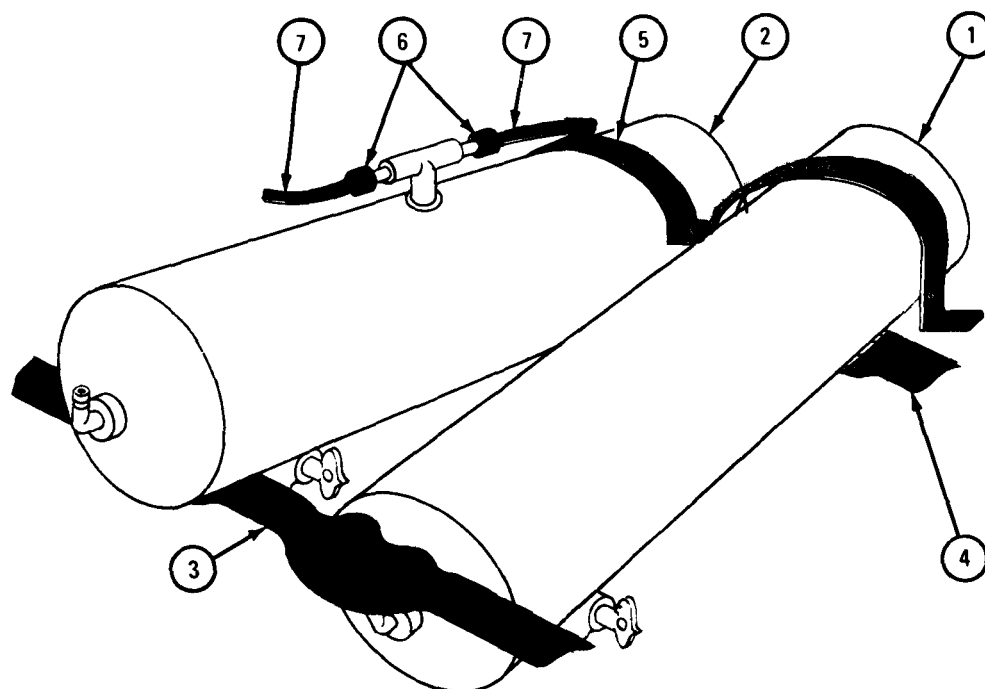

TA 080989

FRAME 6

NOTE

Note positions of fittings so that they are put back facing the same way.

1. Using 5/8-inch wrench, unscrew and take out two drain cocks (1).
2. Using 3/4-inch wrench, unscrew and take off safety valve (2).
3. Using adjustable wrench, unscrew and take out two tee fittings (3).
4. Using 3/4-inch wrench, unscrew and take out three elbows (4).

END OF TASK

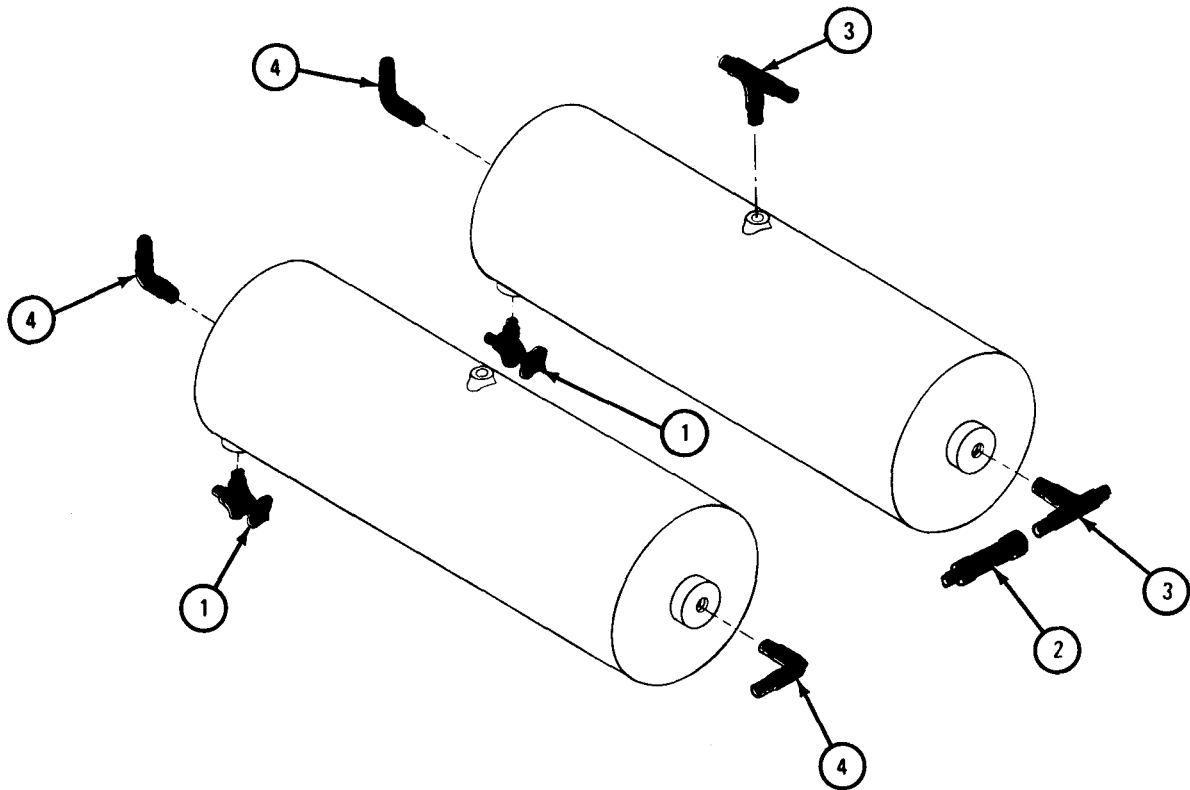

TA 080990

c. Replacement.

NOTE

Put anti-seize tape around fittings before putting them back.

FRAME 1

1. Using 3/4-inch wrench, screw in and tighten three elbows (1) as noted.
2. Using adjustable wrench, screw in and tighten two tee fittings (2).
3. Using 3/4-inch wrench, screw in and tighten safety valve (3).
4. Using 5/8-inch wrench, screw in and tighten two drain cocks (4).

GO TO FRAME 2

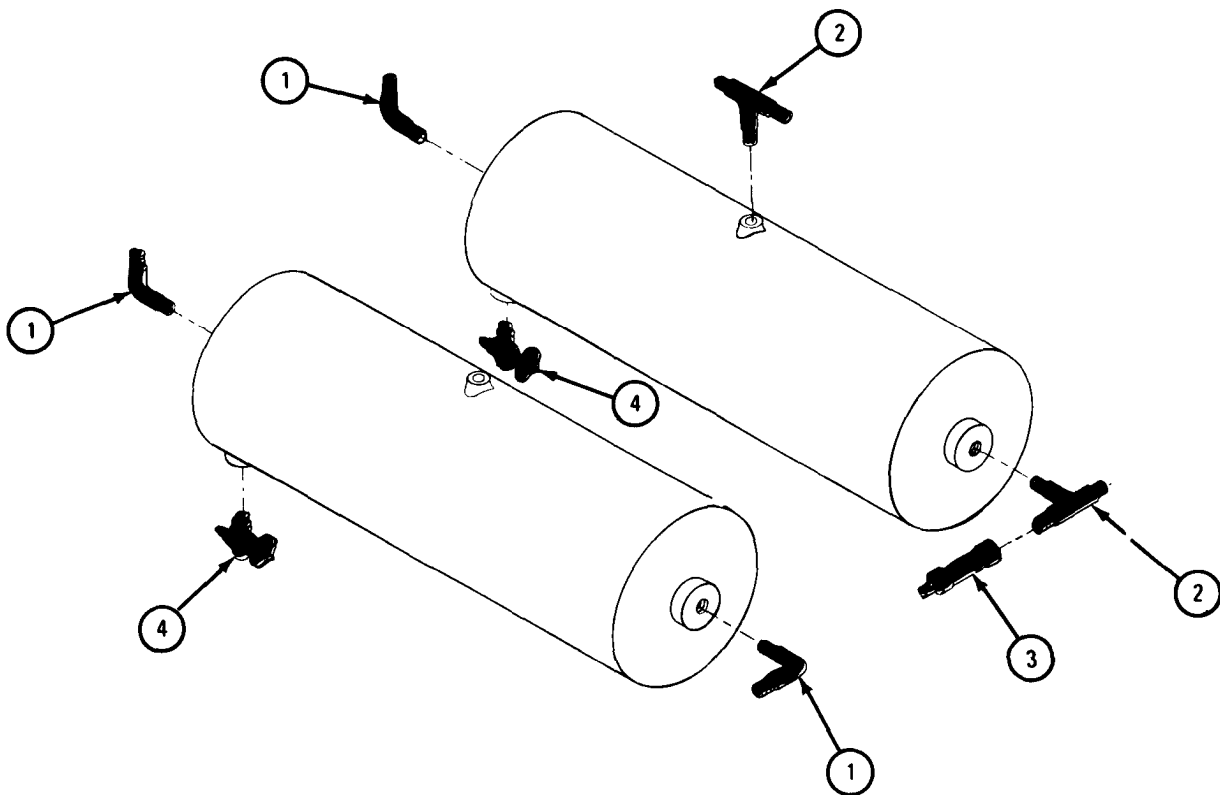

TA 080991

FRAME 2

- Soldiers A and B 1. Lift air reservoir (1) up onto front support (2). Slide air reservoir toward front of truck until rear of air reservoir clears rear support (3).
2. Push up rear of air reservoir (1) and slide it toward back of truck onto rear support (3).
3. Make sure drain cock (4) is pointing straight down.
4. Put retaining strap (5) in place.
- Soldier A 5. Put two tubes (6) in place. Using 5/8-inch wrench, screw on and tighten two coupling nuts (7).
- Soldiers A and B 6. Do steps 1 through 3 again for other air reservoir (8).
- GO TO FRAME 3

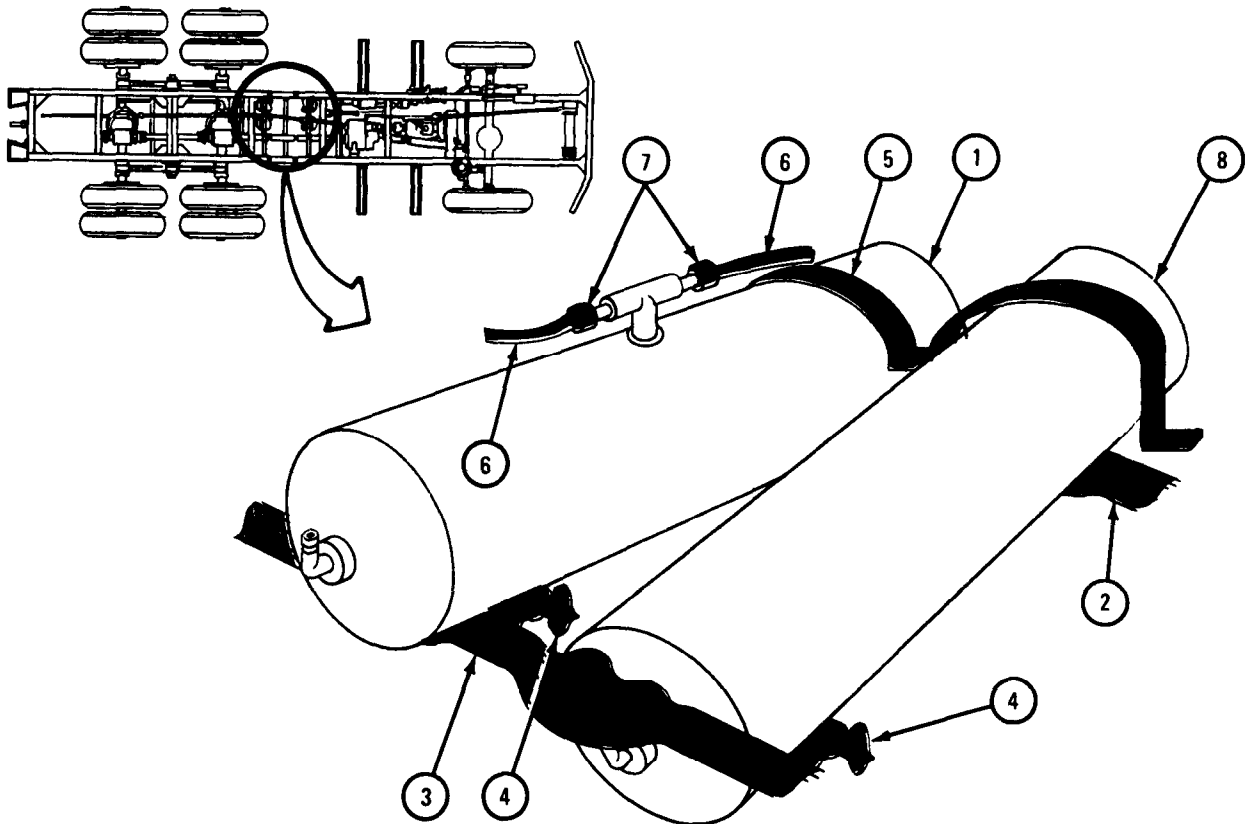

TA 080992

FRAME 3

1. Slide two air reservoirs (1) one inch toward rear of truck.

CAUTION

Do not overtighten coupling nuts. Screw on and finger tighten coupling nuts on fittings, then using wrenches, tighten nuts 1/8 turn.

2. Using 13/16-inch wrench, screw on and tighten coupling nut (2).
3. Using 7/8-inch wrench, screw on and tighten coupling nut (3).
4. Slide two air reservoirs (1) one inch toward front of truck.

GO TO FRAME 4

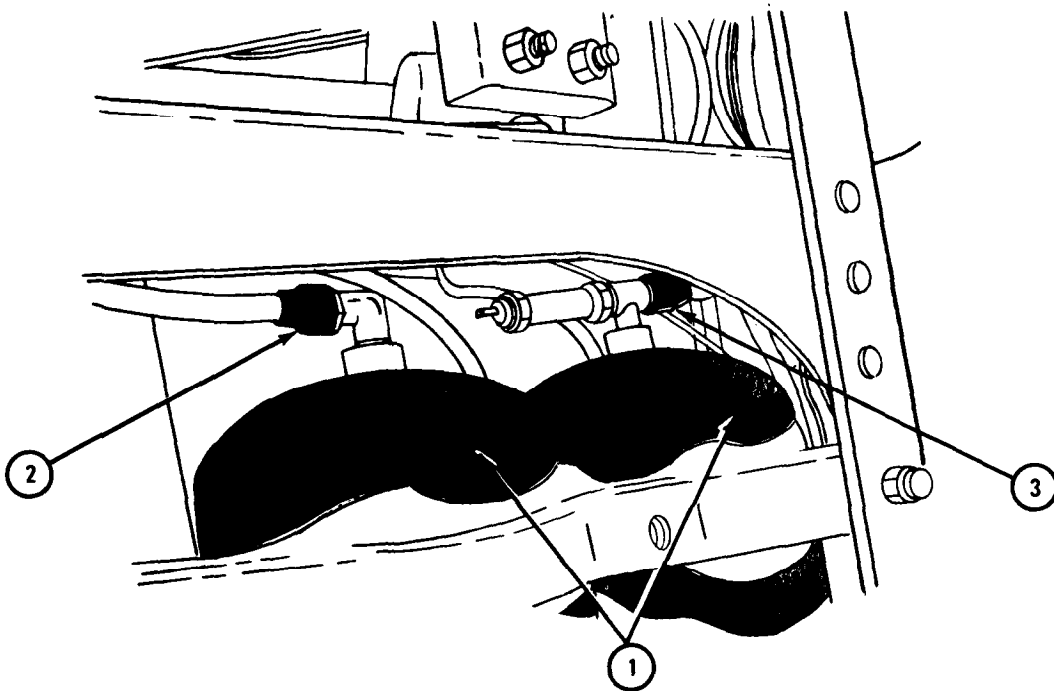

TA 080994

FRAME 4

1. Working in front of air reservoirs (1 and 2), align three screw holes in retaining strap (3) with three screw holes in front support (4). Put capscrew (5) and two capscrews (6) through retaining strap and front support as shown.
2. Using 9/16-inch socket and hinged handle, hold two capscrews (6). Using 9/16-inch wrench, screw on and tighten two locknuts (7).
3. Using 9/16-inch socket and hinged handle, hold capscrew (5). Using 9/16-inch wrench, screw on and tighten locknut (8).

GO TO FRAME 5

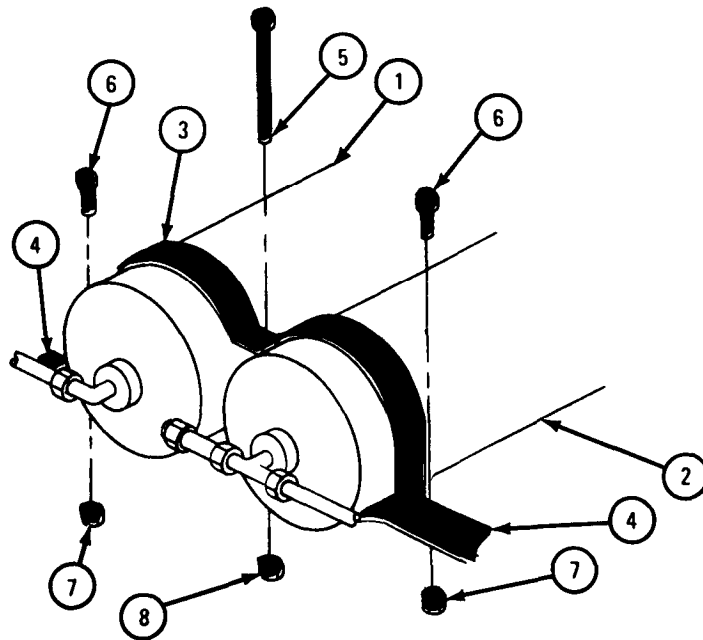

TA 085574

FRAME 5

1. Working at rear of air reservoirs (1 and 2), put retaining strap (3) under tube (4) and over air reservoirs as shown.
2. Align three screw holes in retaining strap (3) with three screw holes in rear support (5). Put capscrew (6) and two capscrews (7) through retaining strap and rear support.
3. Using 9/16-inch socket and hinged handle, hold two capscrews (7). Using 9/16-inch wrench, screw on and tighten two locknuts (8).
4. Using 9/16-inch socket and hinged handle, hold capscrew (6). Using 9/16-inch wrench, screw on and tighten locknut (9).

GO TO FRAME 6

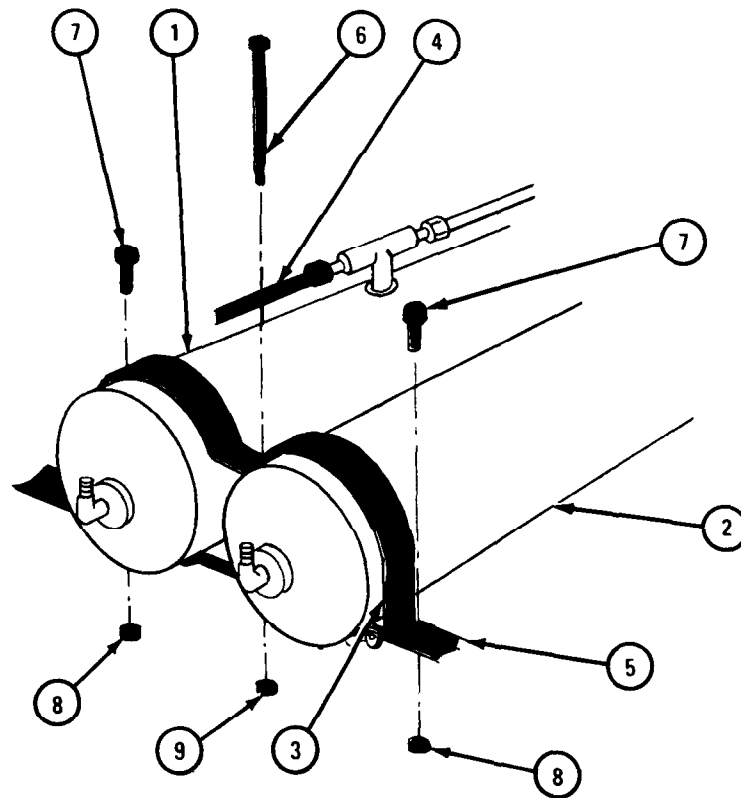

TA 080995

FRAME 6

1. Put tube (1) with two coupling nuts (2) in place as shown.

CAUTION

Do not overtighten coupling nuts. Screw on and finger tighten coupling nuts on fittings, then using 13/16-inch wrench, tighten nuts 1/8 turn.

2. Using 13/16-inch wrench, screw on and tighten two coupling nuts (2).

NOTE

Follow-on Maintenance Action Required:

1. Check air system for leaks. Refer to Part 1, para 1-5.
2. Replace spare wheel. Refer to TM 9-2320-209-10.
3. Replace delivery pump drive shaft. Refer to Part 3, para 18-59.

END OF TASK

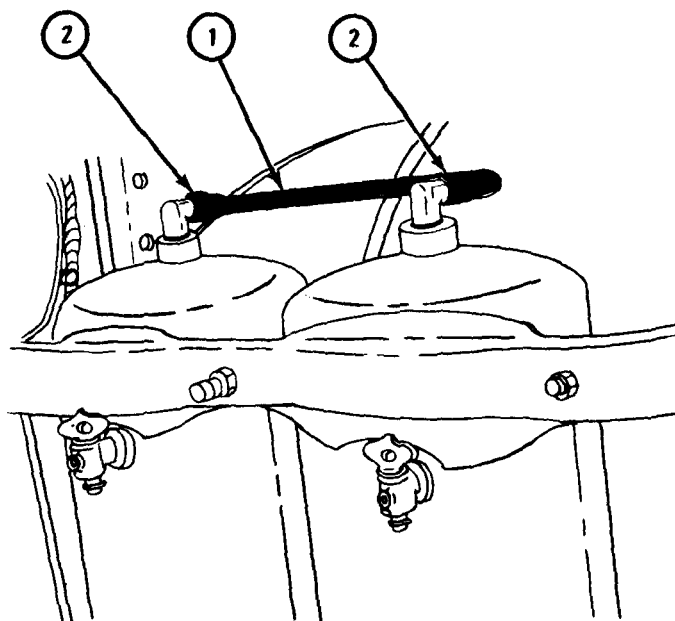

TA 080996

13-28. AIR RESERVOIRS, REMOVAL AND REPLACEMENT (TRUCKS M35A2C, M50A2, M109A3, M185A3, AND M756A2).

TOOLS: 5/8-inch wrench
 9/16-inch wrench (2)
 7/8-inch wrench (2)
 1 3/8-inch wrench
 1 1/16-inch wrench
 1-inch wrench
 3/4-inch wrench

SUPPLIES: Anti-seize tape, MIL-T-27730A

PERSONNEL: Two

EQUIPMENT CONDITION: Truck parked, engine off, handbrake set.

a. Preliminary Procedures.

- (1) Vent air system pressure. Refer to para 13-20.
- (2) Remove spare wheel. Refer to TM 9-2320-209-10.

b. Removal.

FRAME 1

1. Working at rear of air reservoirs (1) using 7/8-inch wrenches, hold adapter (2) and unscrew coupling nut (3).
 2. Using 7/8-inch wrench, unscrew and take off coupling nut (4) and tube (5).
- GO TO FRAME 2

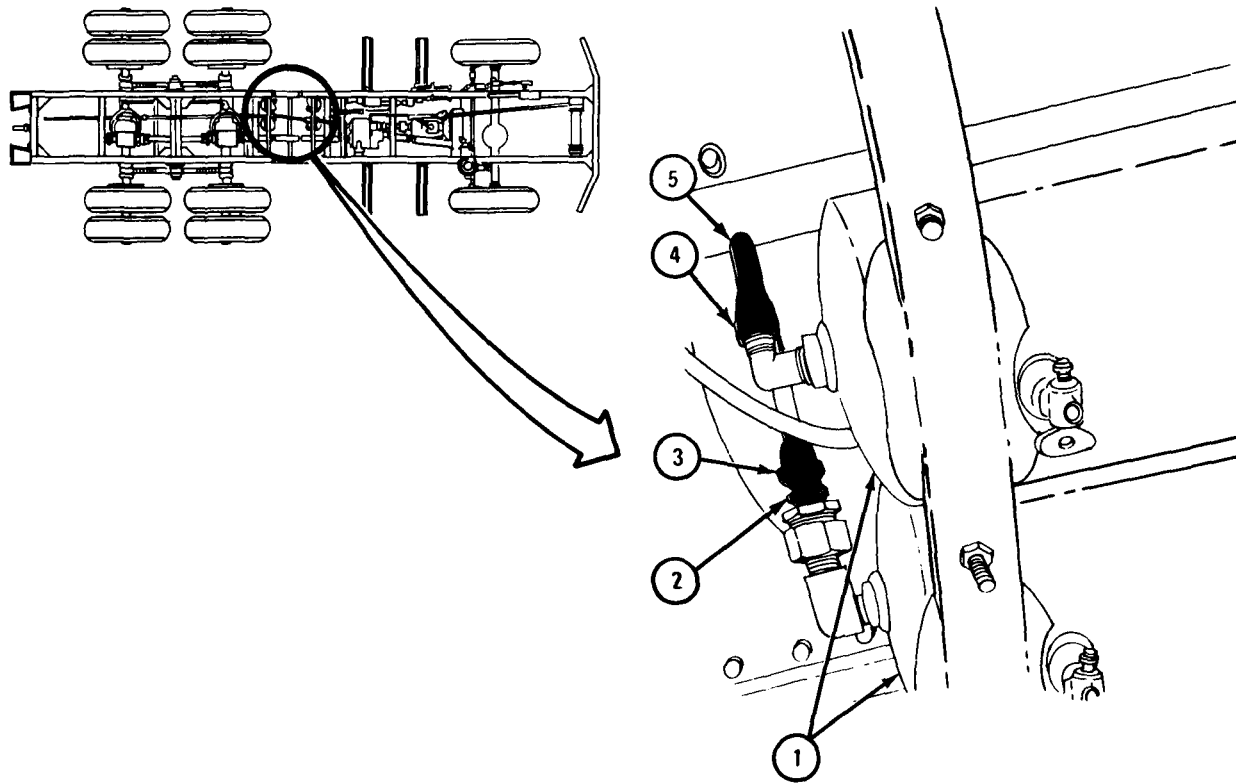

TA 080973

FRAME 2

1. Using 9/16-inch wrenches, unscrew and take out two capscrews (1) and two locknuts (2).
2. Using 9/16-inch wrenches, unscrew and take out capscrew (3) and locknut (4).
3. Take off bracket (5).

GO TO FRAME 3

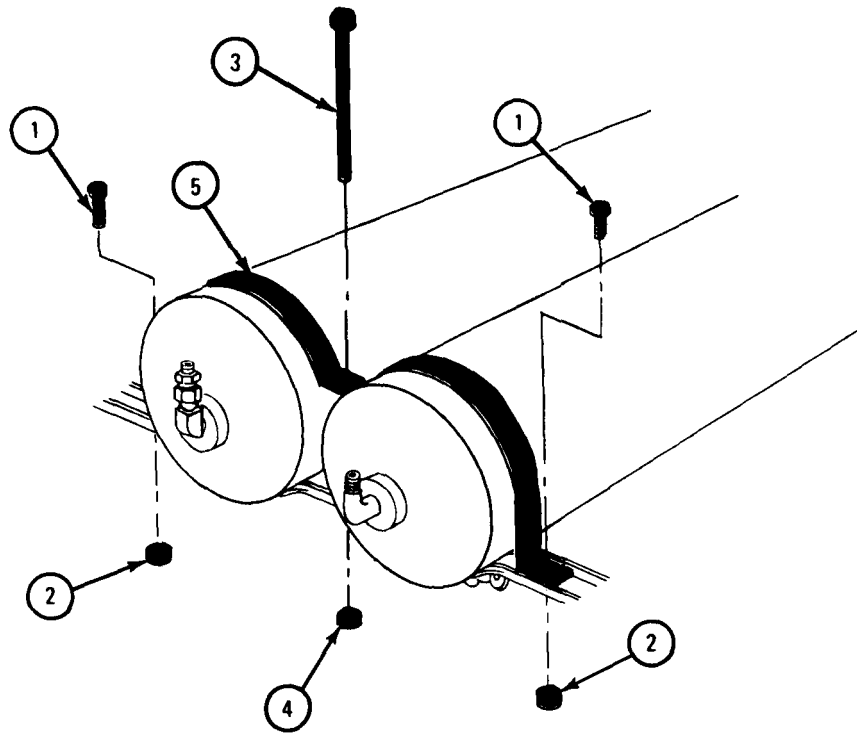

TA 080974

FRAME 3

1. Using 9/16-inch wrenches, unscrew and take out capscrew (1) and locknut (2).
2. Using 9/16-inch wrenches, unscrew and take out capscrew (3) and locknut (4).
3. Bend up bracket (5).

GO TO FRAME 4

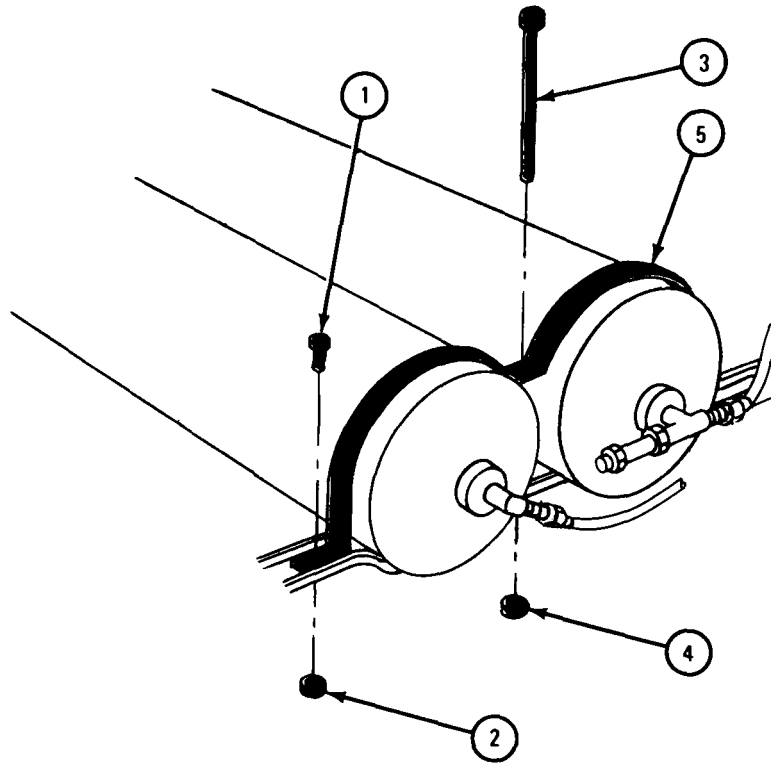

TA 080976

FRAME 4

1. Slide two air reservoirs (1) one inch toward rear of truck.
2. Working at front of air reservoirs (1) and using 7/8-inch wrench, unscrew coupling nuts (2 and 3).

GO TO FRAME 5

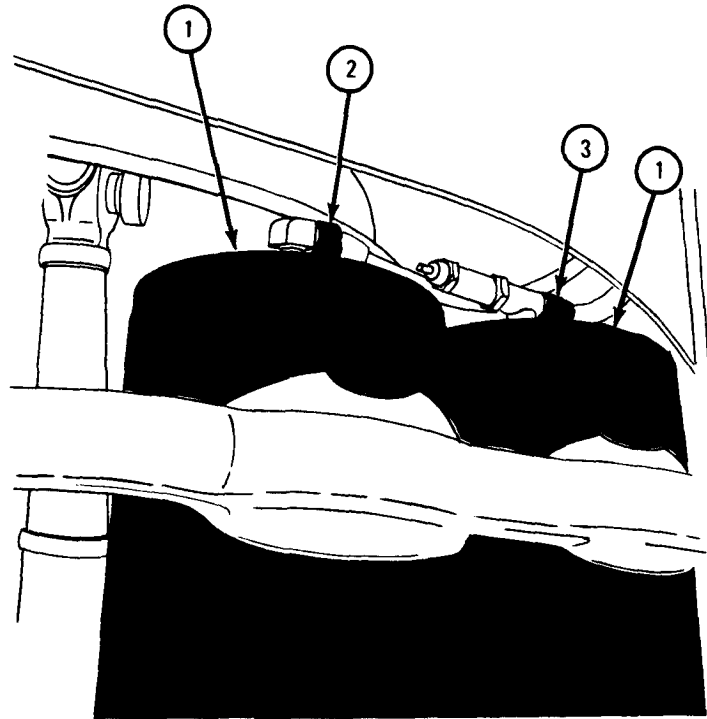

TA 080975

FRAME 5

- Soldiers A and B
1. Working at rear of air reservoirs (1 and 2), lift and slide inside air reservoir (1) toward front of truck until air reservoir is off rear support (3) as shown.
 2. Pull air reservoir (1) down below rear support (3). Slide air reservoir off front support (4) and take air reservoir out from under truck.
 3. Using 5/8-inch wrench, unscrew and take off two tube nuts (5).
 4. Do steps 1 and 2 again to take out air reservoir (2).

GO TO FRAME 6

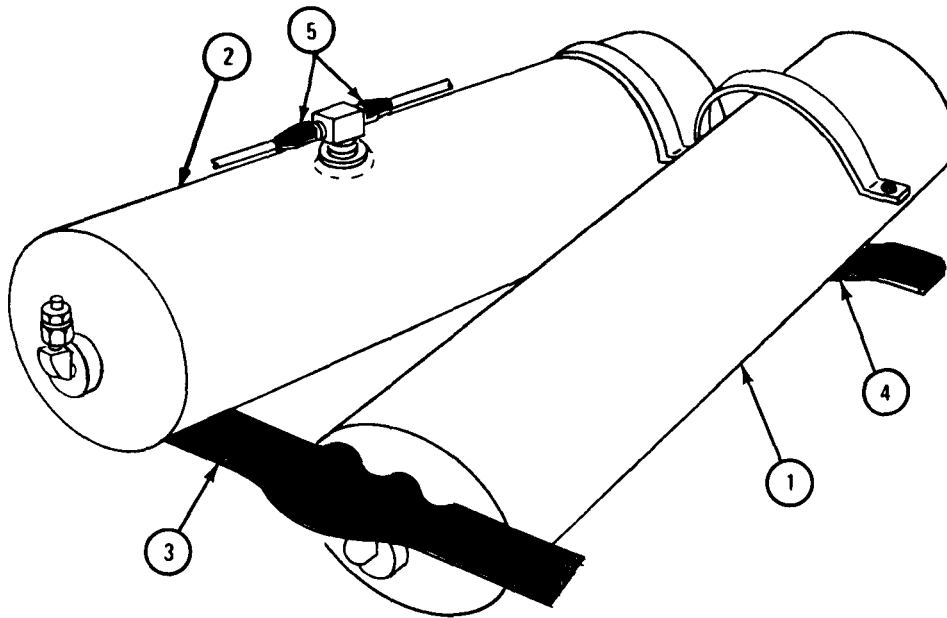

TA 080977

FRAME 6

1. Using 9/16-inch wrenches, unscrew and take out capscrew (1) and nut (2).
2. Take bracket (3) off front support (4).

GO TO FRAME 7

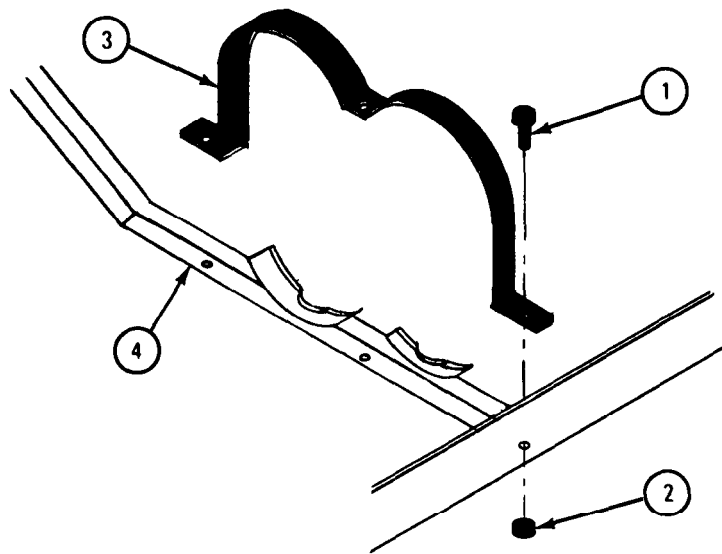

TA 086460

FRAME 7

NOTE

Note positions of fittings so that they are put back facing the same way.

1. Using 5/8-inch wrench, unscrew and take off two drain cocks (1).
2. Using 3/4-inch wrench, unscrew and take off safety valve (2).
3. Using 7/8-inch wrench, unscrew and take off tee fitting (3).
4. Using 3/4-inch wrench, unscrew and take off elbow (4).
5. Using 1 3/8-inch wrench, unscrew and take off elbow (5).
6. Using 1 3/8-inch wrench, hold valve (6). Using 7/8-inch wrench, unscrew and take off adapter (7).
7. Using 1 3/8-inch wrench, unscrew and take off valve (6).
8. Using 1-inch wrench, unscrew and take off elbow (8).
9. Using 11/16-inch wrench, unscrew and take off tee fitting (9).

END OF TASK

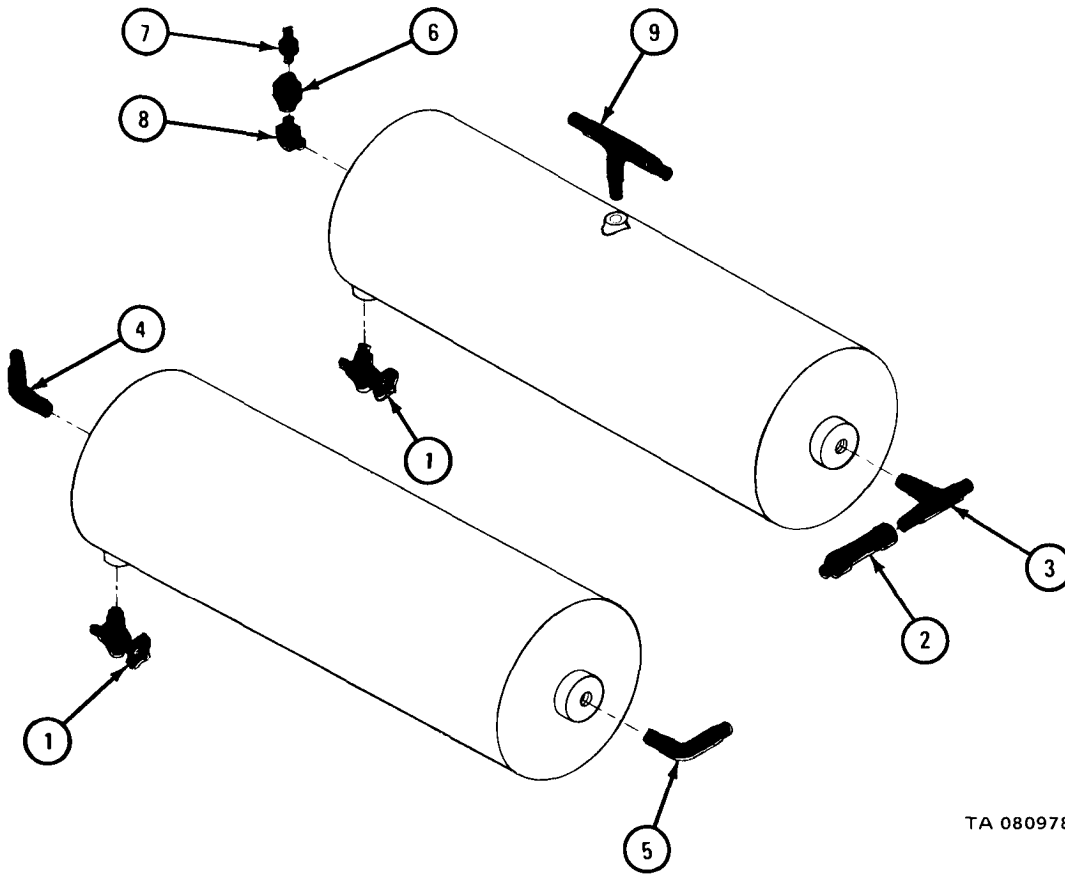

TA 080978

c. Replacement.

NOTE

Put anti-seize tape around fittings before replacement.

FRAME 1

1. Using 1-inch wrench, screw in and tighten elbow (1) to position noted.
2. Using 1 3/8-inch wrench, screw on and tighten valve (2).
3. Using 7/8-inch wrench, screw in and tighten adapter (3).
4. Using 3/4-inch wrench, screw in and tighten elbow (4) to position noted.
5. Using 5/8-inch wrench, screw in and tighten elbow (5) to position noted.
6. Using 7/8-inch wrench, screw in and tighten tee fitting (6) to position noted.
7. Using 3/4-inch wrench, screw in and tighten safety valve (7) to position noted.
8. Using 5/8-inch wrench, screw in and tighten two drain cocks (8).
9. Using 11/16-inch wrench, screw in and tighten tee fitting (9).

GO TO FRAME 2

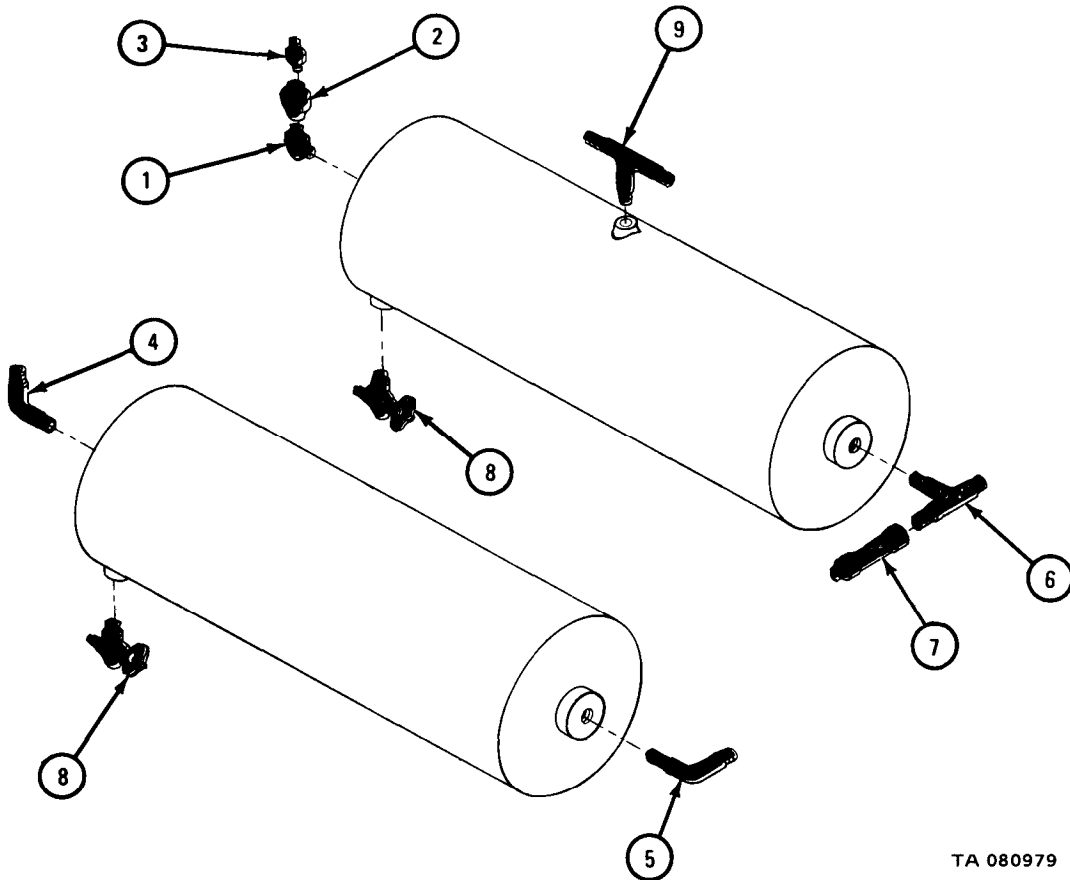

TA 080979

FRAME 2

1. Put front bracket (1) on front support (2) and aline screw holes.
2. Using 9/16-inch wrench, put in and hold capscrew (3). Using 9/16-inch wrench, screw on and tighten nut (4).
3. Bend up front bracket (1).

GO TO FRAME 3

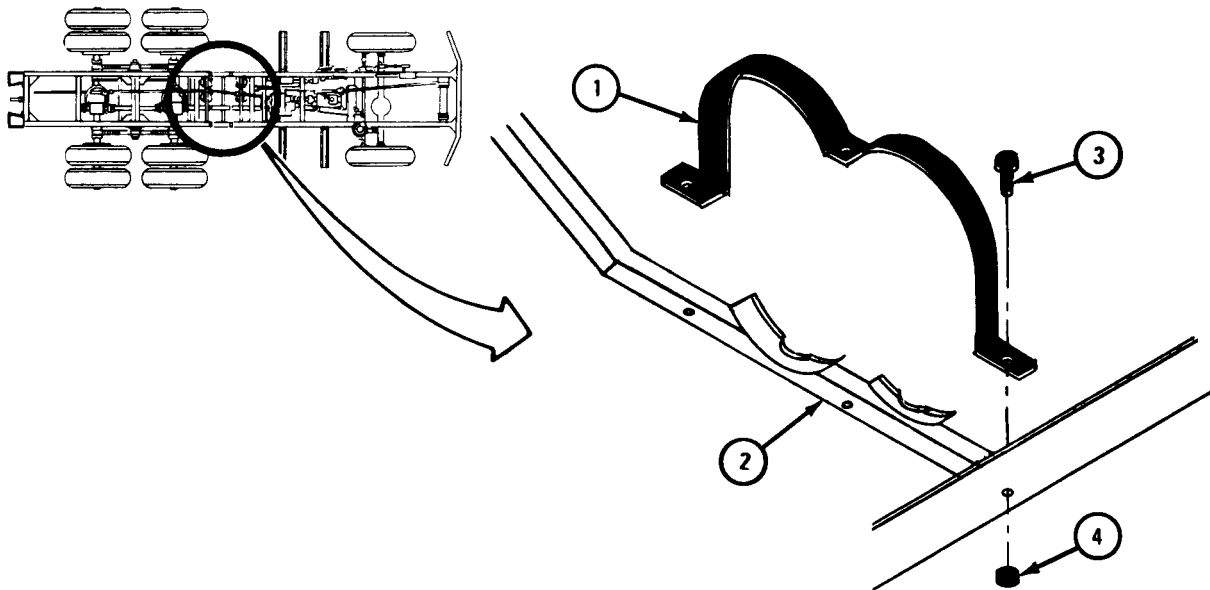

TA 086461

FRAME 3

Soldiers A and B 1. Lift air reservoir (1) up onto front support (2). Slide air reservoir toward front of truck until rear of air reservoir clears rear support (3).

2. Push up rear of air reservoir (1) and slide it toward back of truck onto rear support (3).

3. Make sure drain cock (4) is pointing straight down.

Soldier A 4. Using 5/8-inch wrench, screw on and tighten two tube nuts (5).

Soldiers A and B 5. Do steps 1 through 3 again for air reservoir (6).

GO TO FRAME 4

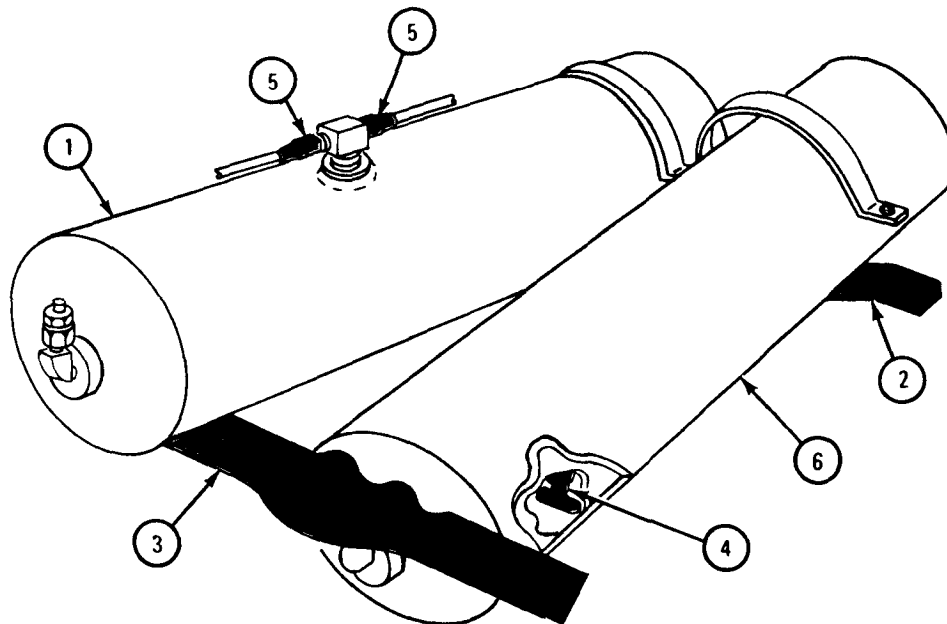

TA 080980

FRAME 4

CAUTION

Do not overtighten coupling nuts (1 and 2). Screw on and finger tighten coupling nuts onto fittings, then using 7/8-inch wrench, tighten nuts.

1. Slide two air reservoirs (3) one inch toward rear of truck.
2. Working at front of air reservoirs (3) and using 7/8-inch wrench, screw on and tighten two coupling nuts (1 and 2) .
3. Slide two air reservoirs (3) one inch toward front of truck.

GO TO FRAME 5

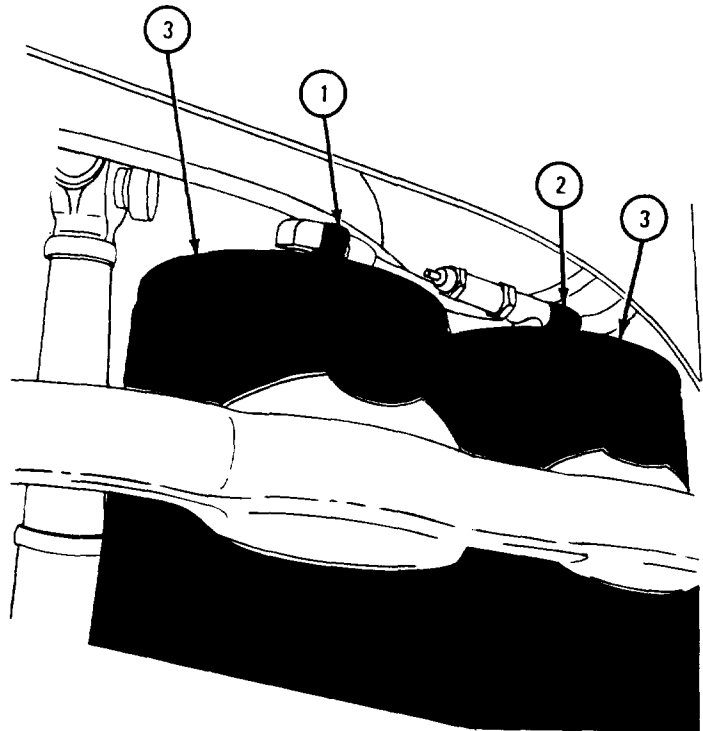

TA 080982

FRAME 5

1. Working at front of air reservoirs (1 and 2), bend bracket (3) into place and align screw holes.
 2. Using 9/16-inch wrench, put in and hold two capscrews (4 and 5).
 3. Using 9/16-inch wrench, screw on and tighten two locknuts (6 and 7).
- GO TO FRAME 6

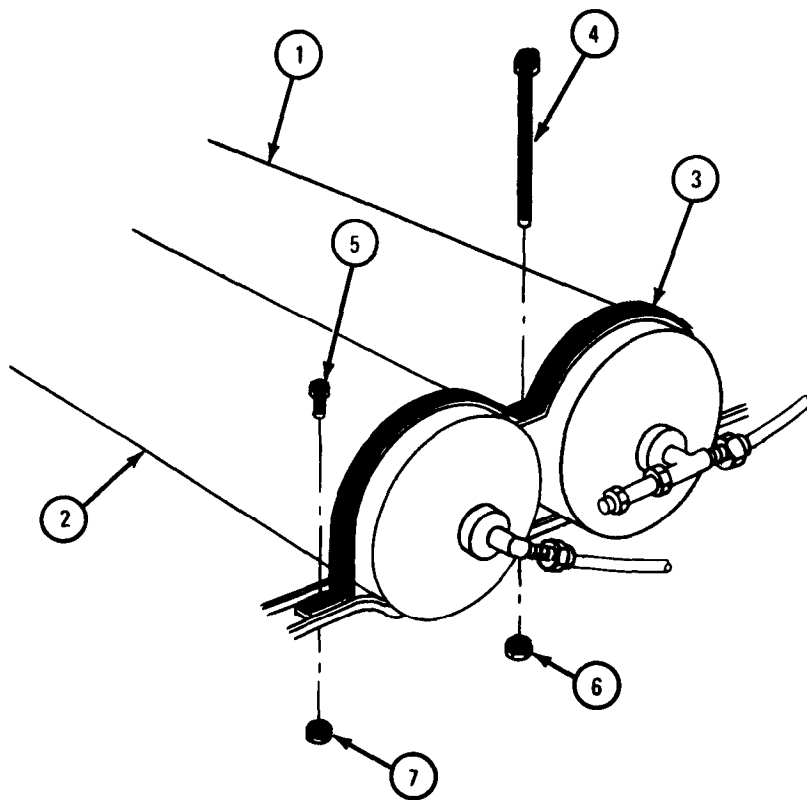

TA 080981

FRAME 6

1. Working at rear of air reservoirs (1 and 2), put bracket (3) into place and align screw holes.
2. Using 9/16-inch wrench, put in and hold two capscrews (4) and capscrew (5).
3. Using 9/16-inch wrench, screw on and tighten three locknuts (6).

GO TO FRAME 7

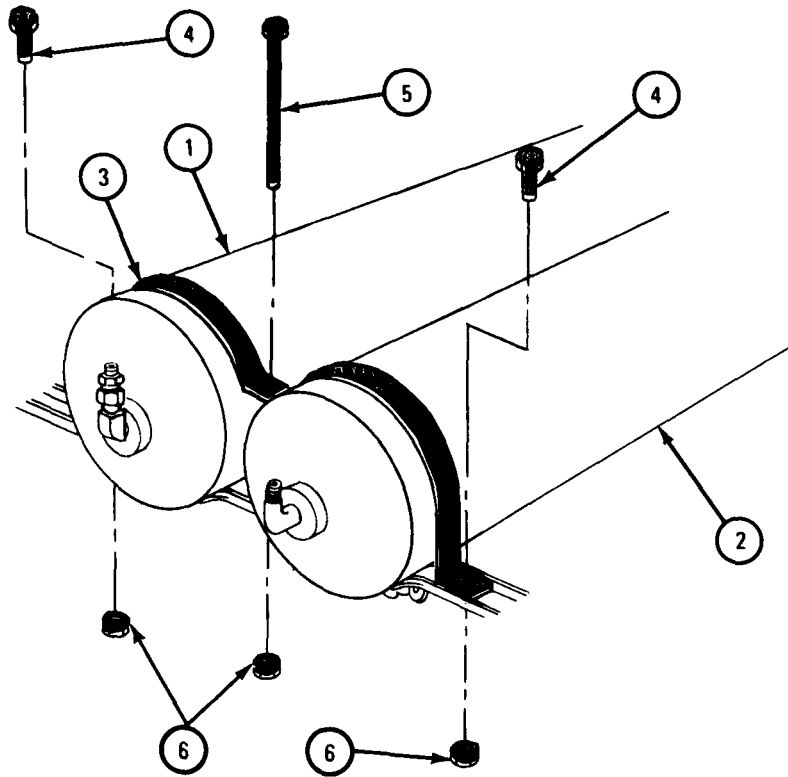

TA 086459

FRAME 7

1. Put tube (1) with coupling nuts (2 and 3) in place as shown.

CAUTION

Do not overtighten coupling nuts (2 and 3). Screw on and finger tighten coupling nuts onto fittings, then using 7/8-inch wrench, tighten nuts.

2. Using 7/8-inch wrenches, hold adapter (4) and screw on and tighten coupling nut (2).
3. Using 7/8-inch wrench, screw on and tighten coupling nut (3).

NOTE

Follow-on Maintenance Action Required:

1. Start engine and let air pressure build. Refer to TM 9-2320-209-10.
2. Check for leaks. Refer to para 1-5.
3. Replace spare tire. Refer to TM 9-2320-209-10.

END OF TASK

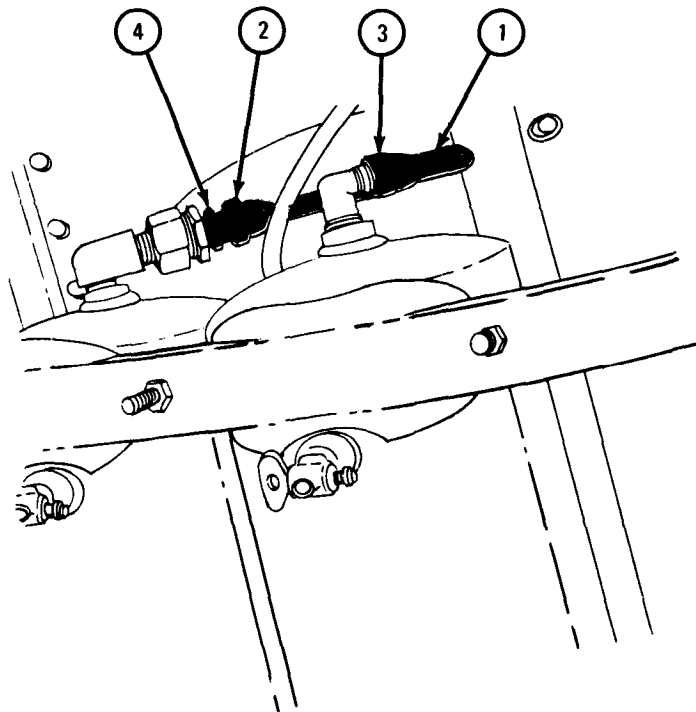

TA 080984

13-29. AIR RESERVOIRS REMOVAL AND REPLACEMENT (TRUCK M764).

TOOLS: 13/16-inch wrench
 5/8-inch wrench
 9/16-inch wrench (2)
 3/4-inch wrench
 7/8-inch wrench

SUPPLIES: None

PERSONNEL: Two

EQUIPMENT CONDITION: Truck parked, engine off, handbrake set.

a. Preliminary Procedures.

- (1) Vent air system pressure. Refer to para 13-20.
- (2) Remove spare tire. Refer to TM 9-2320-209-10.

b. Removal.

- (1) Left side air tank.

FRAME 1

1. Working on top of air reservoir (1) using 5/8-inch wrench, unscrew two coupling nuts (2).
2. Working at front of air reservoir (1) and using 7/8-inch wrench, unscrew coupling nut (3).
3. Using 9/16-inch wrenches, unscrew and take off two capscrews (4) and locknuts (5). Take off retaining strap (6).

GO TO FRAME 2

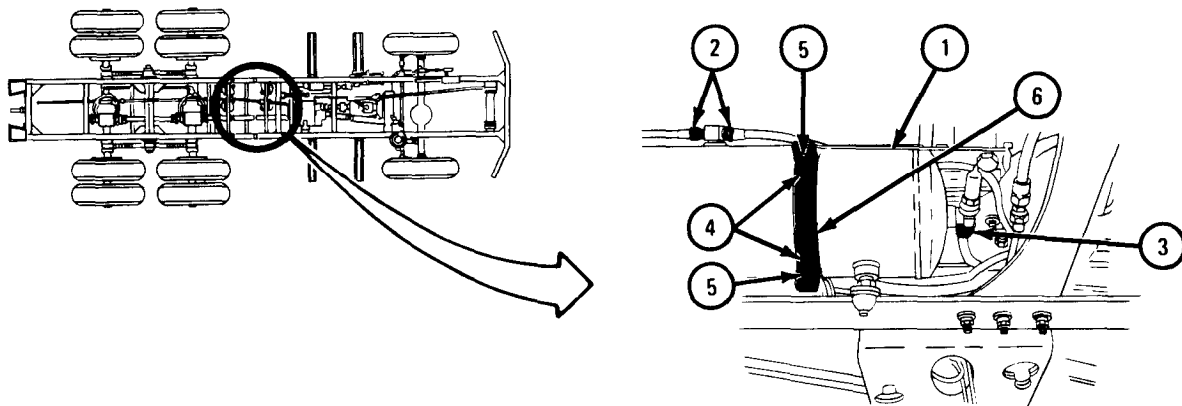

TA 080961

FRAME 2

Soldier A 1. Working at rear of air reservoir (1) and using 13/16-inch wrench, unscrew and take off coupling nut (2).

Soldier B 2. Hold air reservoir (1) in place to keep it from falling.

Soldier A 3. Using 9/16-inch wrenches, unscrew and take off two capscrews (3) and locknuts (4). Take off retaining strap (5).

Soldiers 4. Take off air reservoir (1).
A and B

GO TO FRAME 3

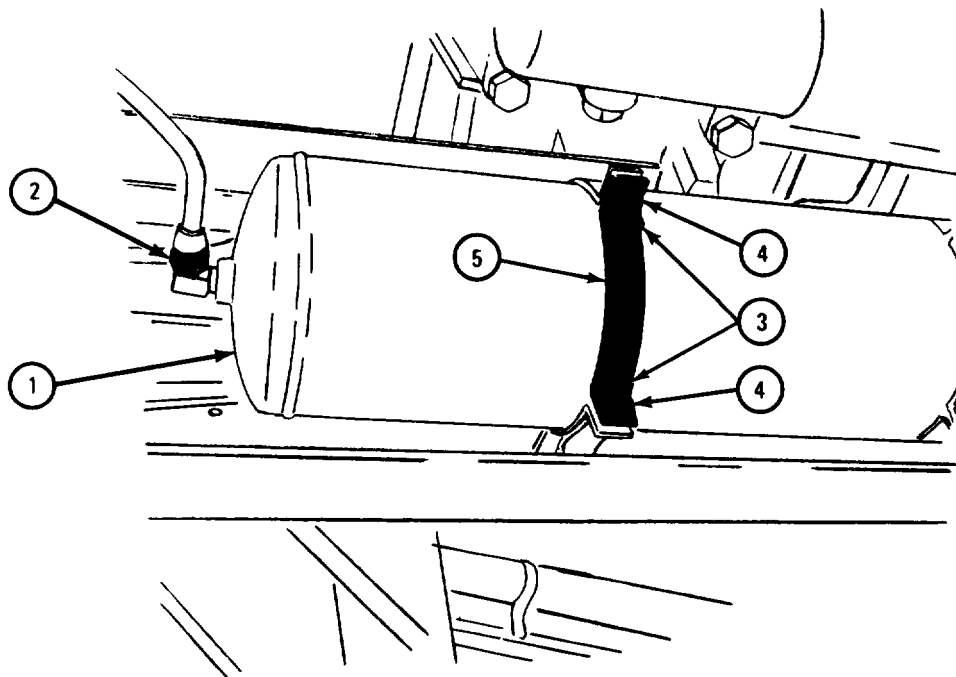

TA 080962

FRAME 3

NOTE

Note positions of fittings before taking them off so that they are put back the same way.

1. Using 3/4-inch wrench, unscrew and take off safety valve (1).
2. Using 7/8-inch wrench, unscrew and take off tee fitting (2). Using 3/4-inch wrench, unscrew and take out elbow fitting (3).
3. Using 11/16-inch wrench, unscrew and take off drain cock (4).
4. Using 3/4-inch wrench, unscrew and take off tee fitting (5).

END OF TASK

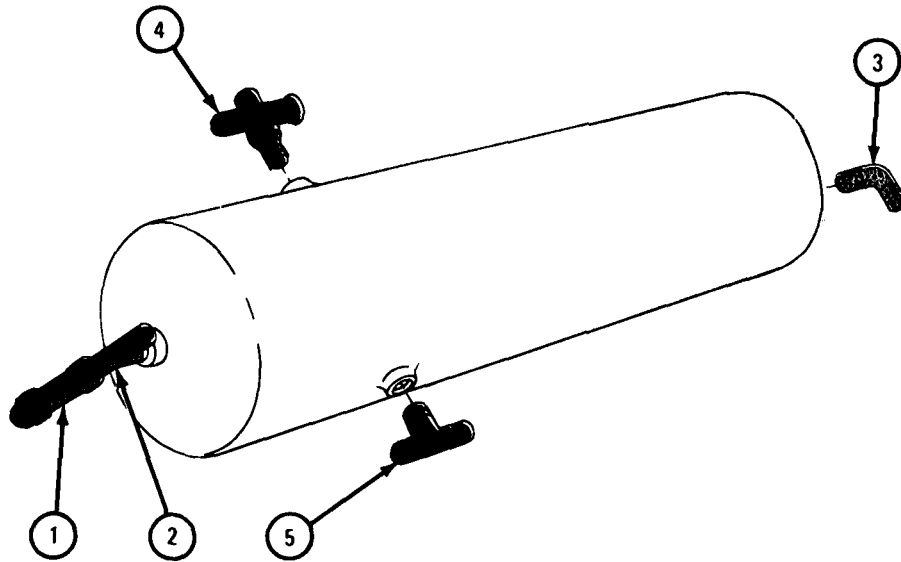

TA 080963

(2) Right side air tank.

FRAME 1

1. Working at front of air reservoir (1) using 13/16-inch wrench, unscrew coupling nut (2).
2. Using 9/16-inch wrenches, unscrew and take off two capscrews (3) and locknuts (4). Take off retaining strap (5).

GO TO FRAME 2

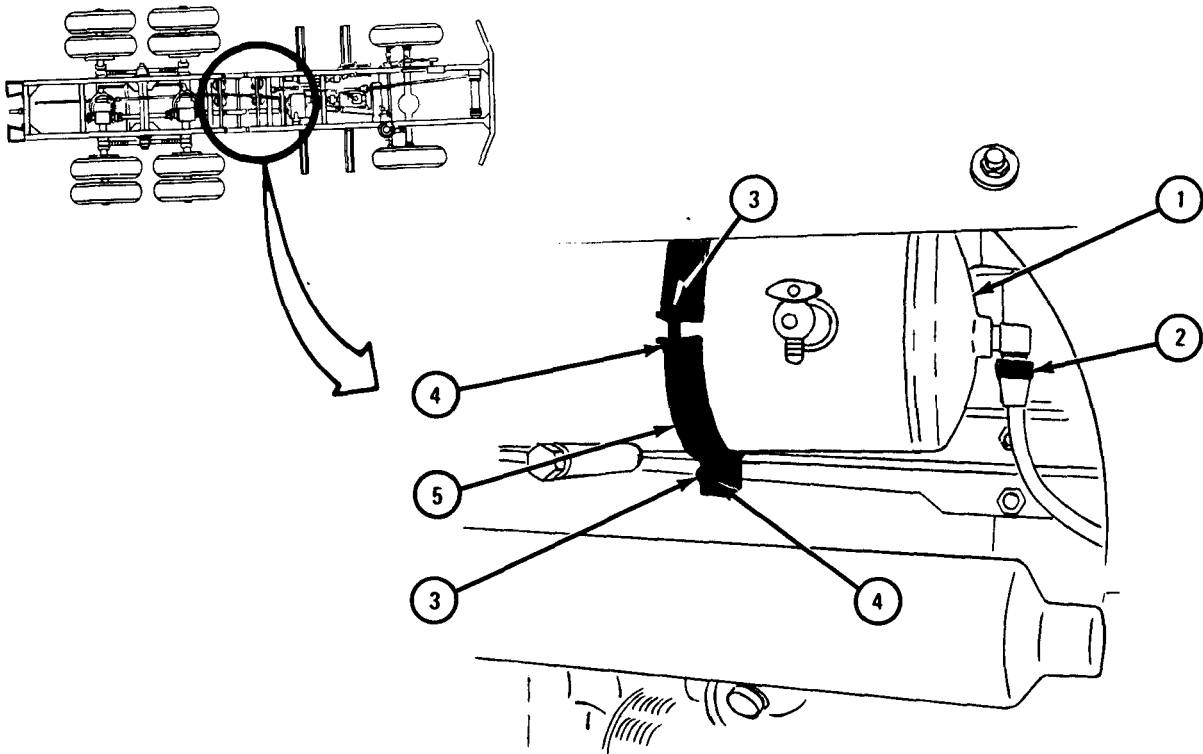

TA 080967

FRAME 2

- Soldier A 1. Working at rear of air reservoir (1) and using 13/16-inch wrench, unscrew and take off coupling nut (2).
- Soldier B 2. Hold air reservoir (1) in place to keep it from falling.
- Soldier A 3. Using 9/16-inch wrenches, unscrew and take off two capscrews (3) and locknuts (4). Take off retaining strap (5).
- Soldiers A and B 4. Take off air reservoir (1).
- GO TO FRAME 3

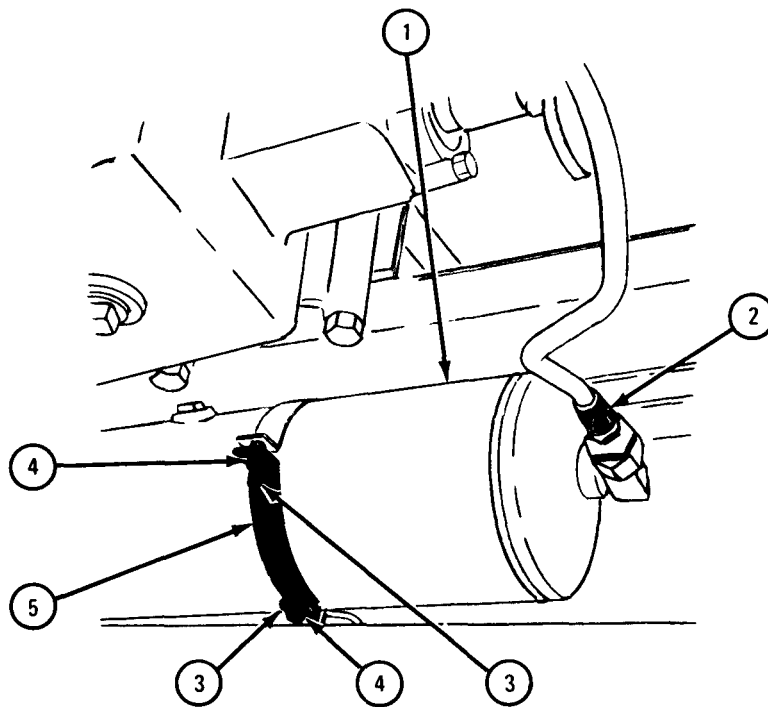

TA 080968

FRAME 3

NOTE

Note positions of fittings before taking them off so they are put back the same way.

1. Using 1 3/8-inch and 13/16-inch wrenches, hold valve (1) and unscrew and take off adapter (2).
2. Using 1 3/8-inch wrench, unscrew and take off valve (1).
3. Using 3/4-inch wrench, unscrew and take off elbow fitting (3).
4. Using 1 1/16-inch wrench, unscrew and take off drain cock (4).
5. Using 1-inch wrench, unscrew and take off elbow fitting (5).

END OF TASK

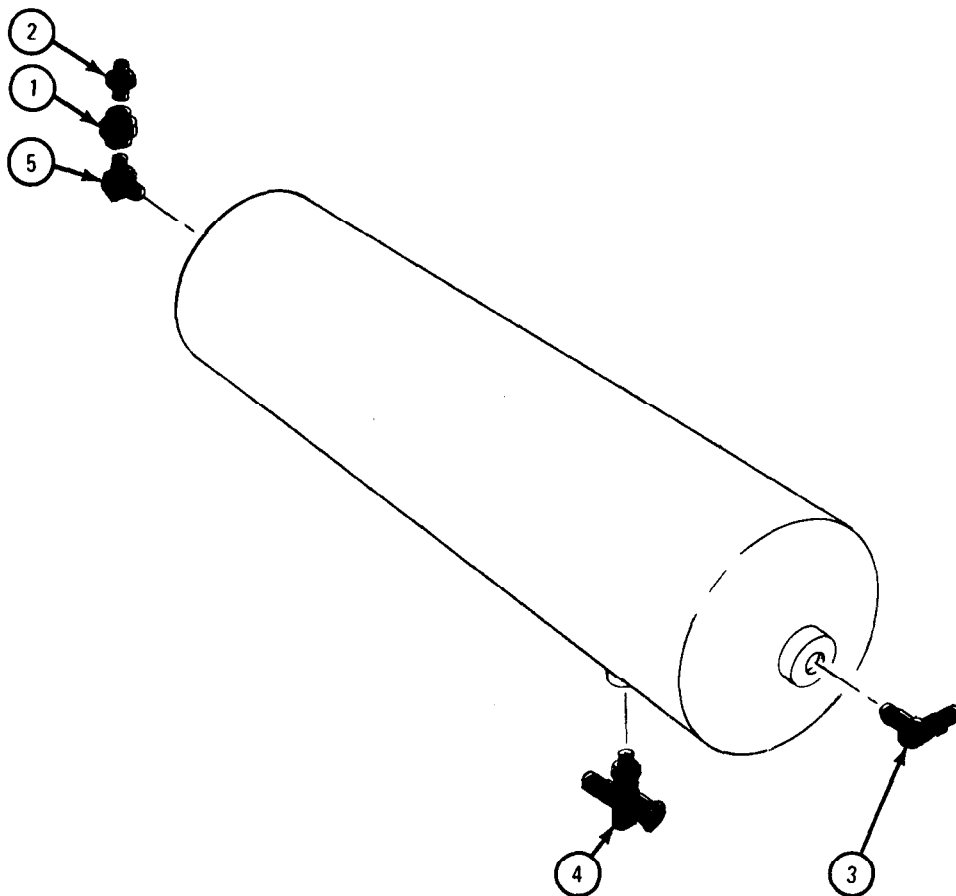

TA 080969

c. Replacement.

(1) Left side air tank.

FRAME 1

1. Using 11/16-inch wrench, screw in and tighten drain cock (1).
2. Using 7/8-inch wrench, screw in and tighten tee fitting (2). Using 3/4-inch wrench, screw in and tighten elbow fitting (3) to positions noted.
3. Using 3/4-inch wrench, screw on and tighten safety valve (4).
4. Using 3/4-inch wrench, screw in and tighten tee fitting (5) to position noted.

GO TO FRAME 2

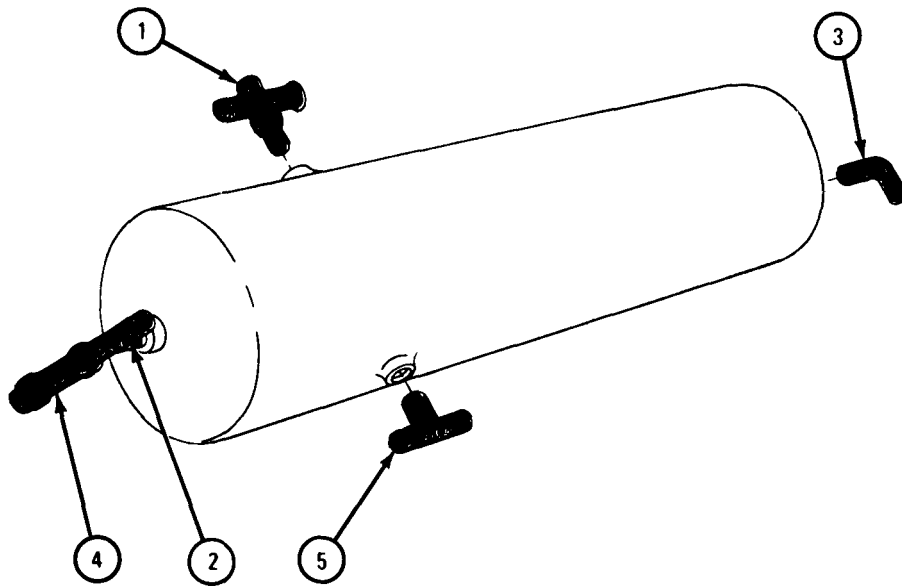

TA 080964

FRAME 2

- Soldiers A and B 1. Working under truck, put air reservoir (1) in place as shown.
- Soldier A 2. Hold air reservoir (1) in place to keep it from falling.
- Soldier B 3. Put on retaining strap (2) and using 9/16-inch wrenches, screw on two capscrews (3) and locknuts (4).

CAUTION

Do not tighten coupling nut (5) too much. Screw on and finger tighten coupling nuts on fitting, then using wrench, tighten nut 1/8 turn.

4. Using 13/16-inch wrench, screw on and tighten coupling nut (5).
5. Working on top of air reservoir (1) and using 5/8-inch wrench, screw on and tighten two coupling nuts (6).

GO TO FRAME 3

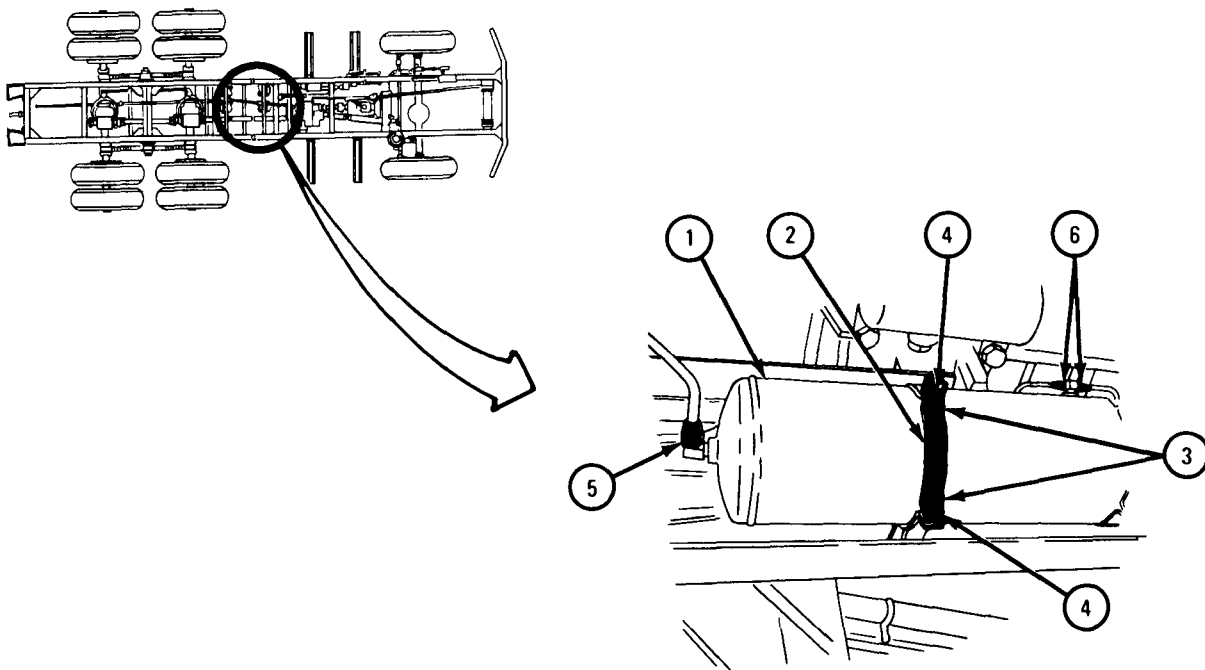

TA 080965

FRAME 3

1. Working at front of air reservoir (1), put on retaining strap (2) as shown.
2. Using 9/16-inch wrenches, screw on and tighten two capscrews (3) and locknuts (4).

CAUTION

Do not tighten coupling nut (5) too much. Screw on and finger tighten coupling nut onto fitting, then using 13/16-inch wrench, tighten nut about 1/8 turn.

3. Using 13/16-inch wrench, screw on and tighten coupling nut (5).

NOTE

Follow-on Maintenance Action Required:

1. Start engine and let air pressure build. Refer to TM 9-2320-209-10.
2. Do air system leak test. Refer to Part 1, para 1-5.
3. Replace spare tire. Refer to TM 9-2320-209-10.

END OF TASK

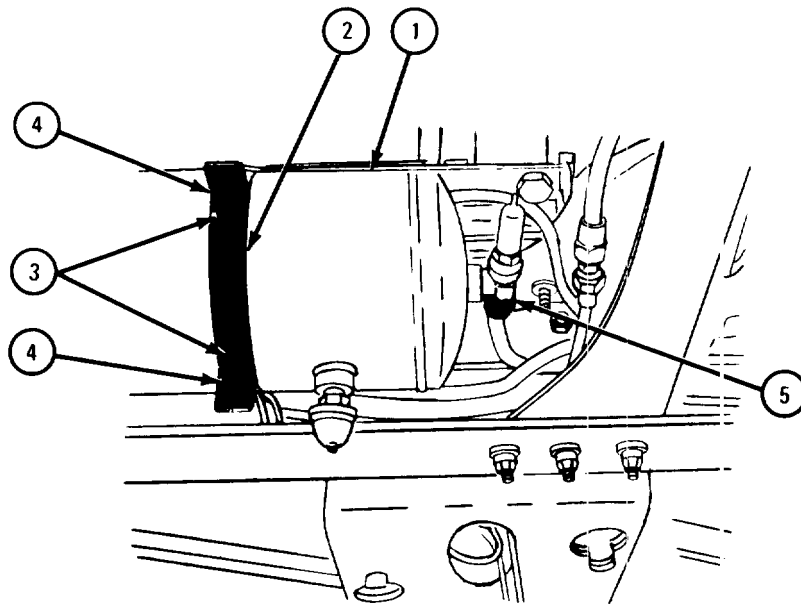

TA. 080966

(2) Right side air tank.

FRAME 1

1. Using 11/16-inch wrench, screw on and tighten drain cock (1).
2. Using 3/4-inch wrench, screw on and tighten two elbow fittings (2) to positions noted.
3. Using 1-inch wrench, screw in and tighten elbow fitting (3).
4. Using 1 3/8-inch wrench, screw on and tighten valve (4).
5. Using 7/8-inch wrench, screw on and tighten adapter (5).

GO TO FRAME 2

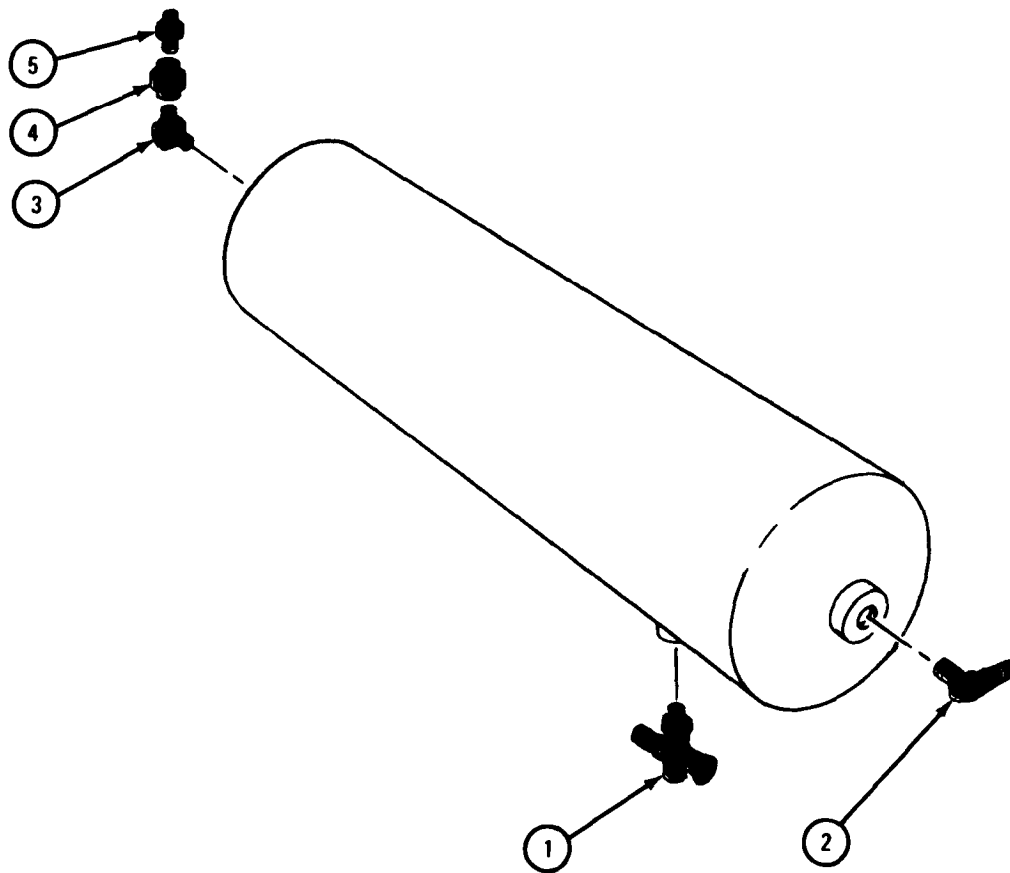

TA 080970

FRAME 2

Soldiers A and B 1. Working under truck, put air reservoir (1) in place as shown.

Soldier A 2. Hold air reservoir (1) in place to keep it from falling.

Soldier B 3. Put on retaining strap (2) and using 9/16-inch wrenches, screw on two capscrews (3) and locknuts (4).

CAUTION

Do not tighten coupling nut (5) too much. Screw on and finger tighten coupling nut onto fitting, then using 13/16-inch wrench, tighten nut 1/8 turn.

4. Using 13/16-inch wrench, screw on and tighten coupling nut (5).

GO TO FRAME 3

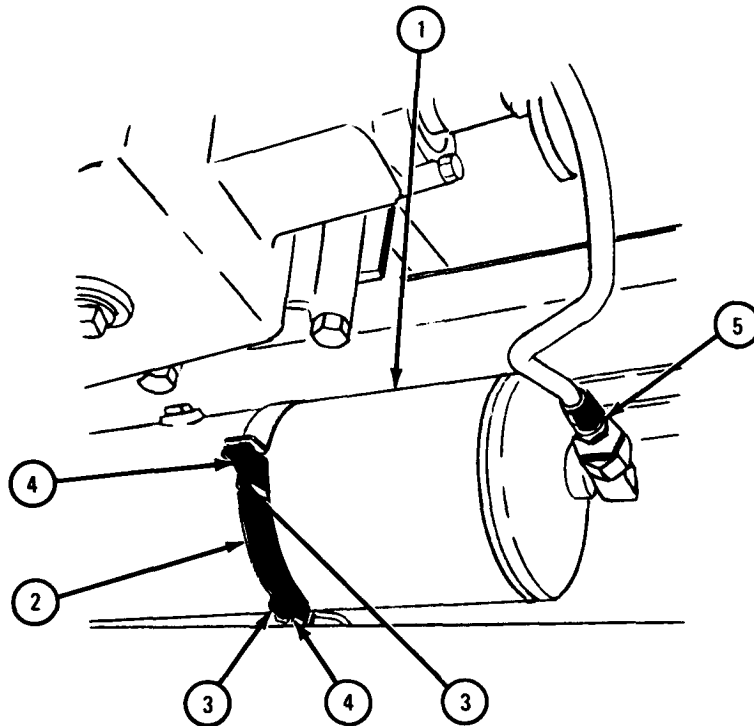

TA 080971

FRAME 3

1. Working at front of air reservoir (1), put on retaining strap (2).
2. Using two 9/16-inch wrenches, screw on and tighten two capscrews (3) and locknuts (4).

CAUTION

Do not tighten coupling nut (5) too much. Screw on and finger tighten coupling nut onto fitting, then using 13/16-inch wrench, tighten nut 1/8 turn.

3. Using 13/16-inch wrench, screw on and tighten coupling nut (5).

NOTE

Follow-on Maintenance Action Required:

1. Start engine and let air pressure build. Refer to TM 9-2320-209-10.
2. Do air system leak test. Refer to Part 1, para 1-5.
3. Replace spare tire. Refer to TM 9-2320-209-10.

END OF TASK

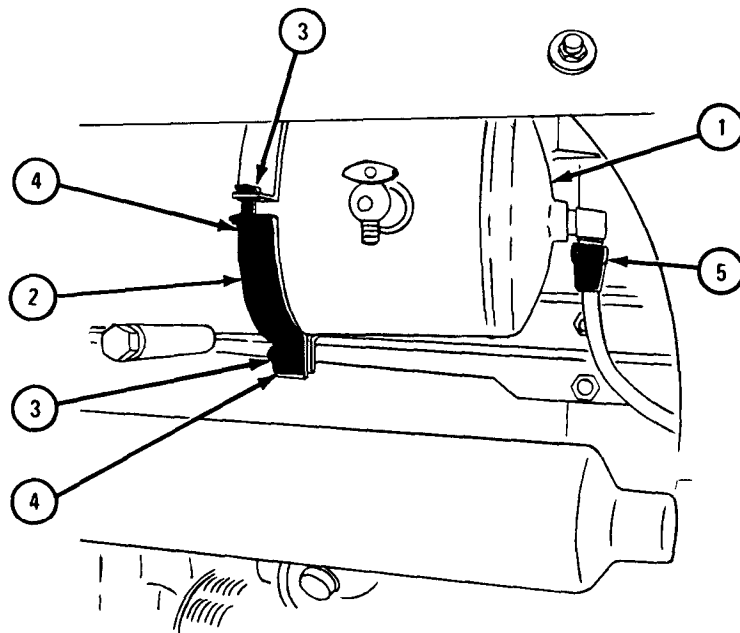

TA 080972

13-30. AIR RESERVOIRS REMOVAL AND REPLACEMENT (TRUCK M35A1).

TOOLS: 13/16-inch wrench
 5/8-inch wrench
 3/4-inch wrench
 Adjustable wrench
 7/8-inch wrench
 7/16-inch socket
 1/2-inch drive ratchet

SUPPLIES: Anit-seize tape, MIL-T-27730A

PERSONNEL: Two

EQUIPMENT CONDITION: Truck parked, engine off, handbrake set.

a. Preliminary Procedures.

- (1) Vent air system pressure. Refer to para 13-20.
- (2) Remove spare wheel. Refer to TM 9-2320-209-10.

b. Removal.

FRAME 1

1. Working at rear of air reservoirs (1) and using 13/16-inch wrench, unscrew coupling nut (2).
 2. Using 13/16-inch wrench, unscrew coupling nut (3). Take off tube (4).
- GO TO FRAME 2

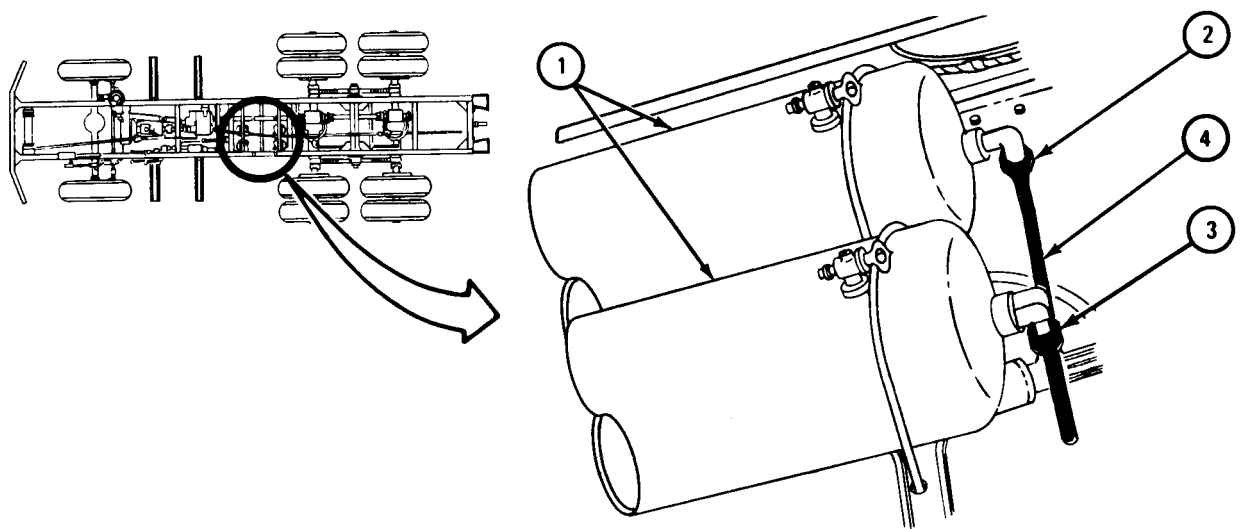

TA 101219

FRAME 2

1. Working at front of air reservoirs (1) and using 13/16-inch wrench, unscrew coupling nut (2).

2. Using 7/8-inch wrench, unscrew coupling nut (3).

GO TO FRAME 3

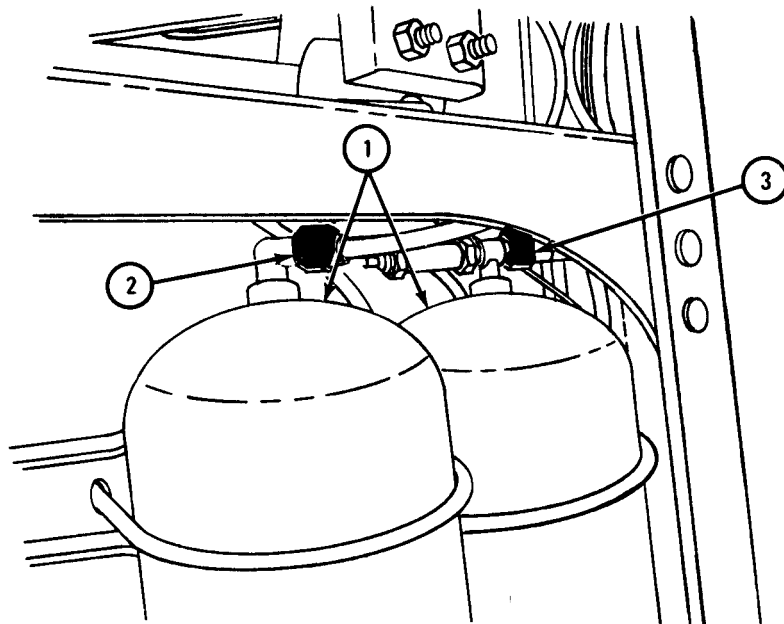

TA 101220

FRAME 3

- Soldier A 1. Hold air reservoir (1) in place. Tell soldier B when ready.
- Soldier B 2. Using 1/2-inch drive ratchet and 7/16-inch socket, unscrew and take off two locknuts (2). Take off U-bolt (3).
3. Working at rear of air reservoir (1), do step 2 again for rear U-bolt (4).
4. Take out air reservoir (1).
- Soldier A 5. Using 5/8-inch wrench, unscrew two coupling nuts (5).
- Soldiers A and B 6. Do steps 1 through 4 again for air reservoir (6).
- GO TO FRAME 4

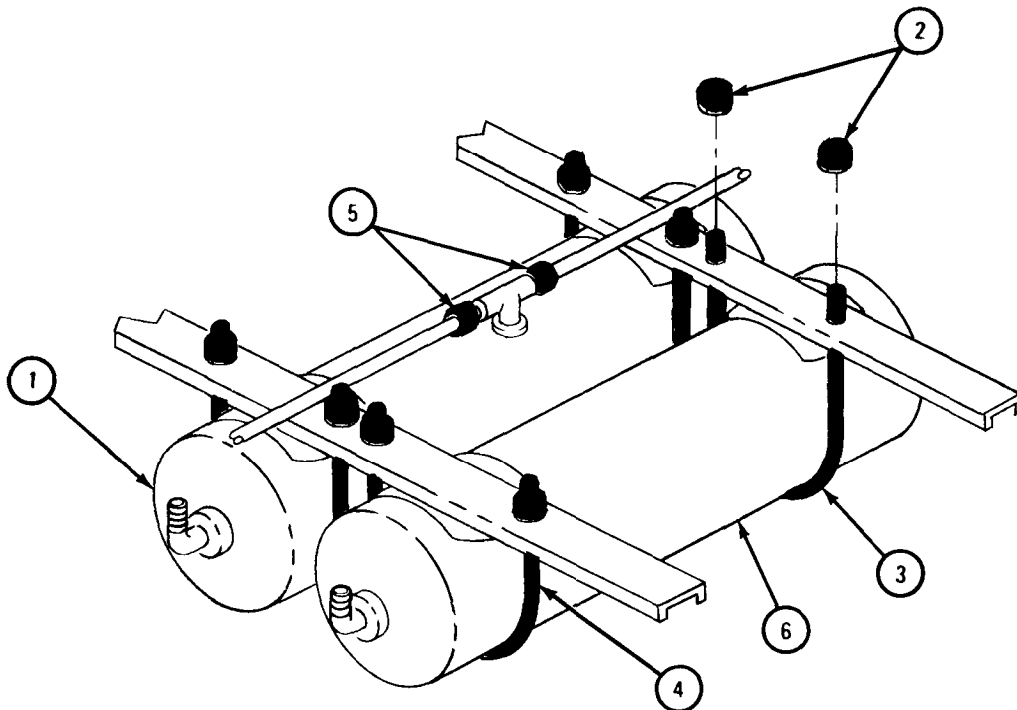

TA 101221

FRAME 4

NOTE

Note position of fittings so that they will be put back in the same place.

1. Using 5/8-inch wrench, unscrew and take off two drain cocks (1).
2. Using 3/4-inch wrench, unscrew and take off safety valve (2). Using adjustable wrench, unscrew and take off two tee fittings (3).
3. Using 5/8-inch wrench, unscrew and take off three elbows (4).

END OF TASK

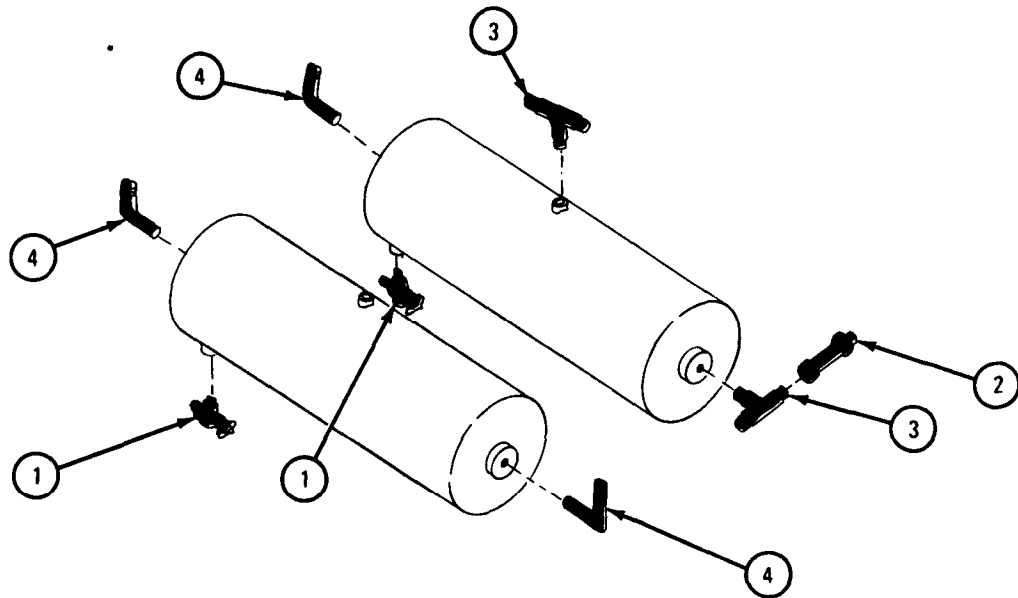

TA 101222

c. Replacement.

FRAME 1

NOTE

Put thread tape on all fittings before putting them back.

1. Using 5/8-inch wrench, screw in and tighten three elbows (1) to position noted.
2. Using adjustable wrench, screw in and tighten two tee fittings (2). Using 3/4-inch wrench, screw in and tighten safety valve (3).
3. Using 5/8-inch wrench, screw in and tighten two drain cocks (4).

GO TO FRAME 2

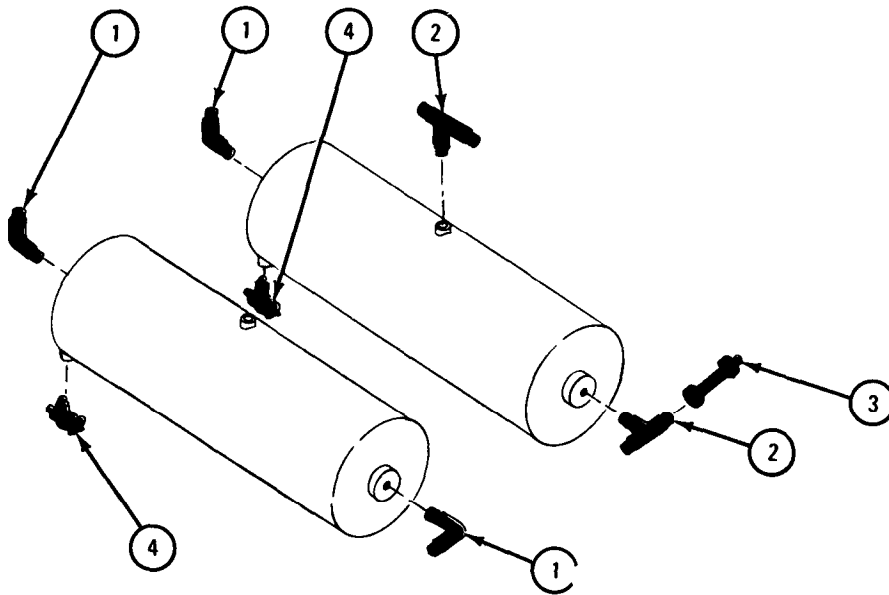

TA 101223

FRAME 2

Soldiers 1. Lift air reservoir (1) into position.
A and B

Soldier A 2. Hold air reservoir (1) in place. Tell soldier B when ready.

Soldier B 3. Working at front of air reservoir (1), put U-bolt (2) in place. Using 1/2-inch drive ratchet and 7/16-inch socket, screw on and tighten two locknuts (3).

4. Working at rear of air reservoir (1), do step 3 again for rear U-bolt (4).

CAUTION

Do not over tighten coupling nuts. Screw on and finger tighten coupling nuts on fittings, then using 5/8-inch wrench, tighten nuts 1/8 turn.

5. Using 5/8-inch wrench, screw on and tighten two coupling nuts (5).

Soldiers 6. Do steps 1 through 4 again for air reservoir (6).
A and B

GO TO FRAME 3

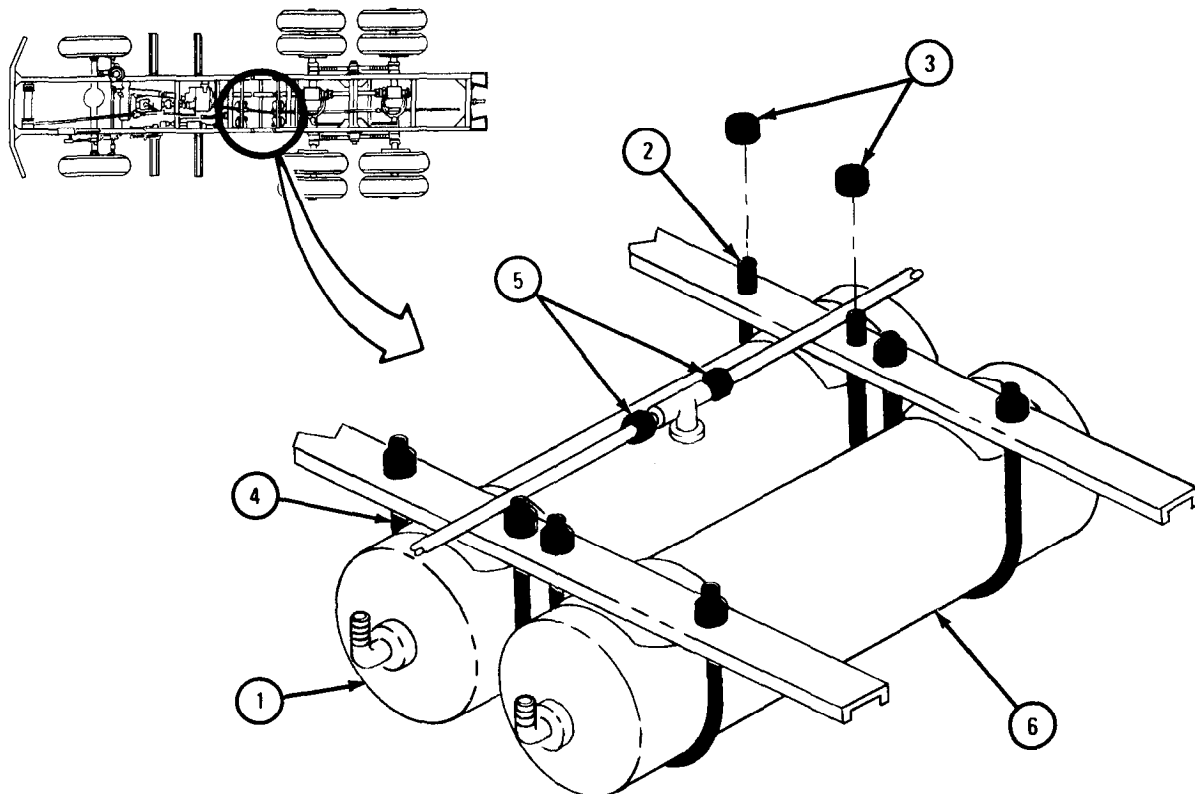

TA 101224

FRAME 3

CAUTION

Do not over tighten coupling nuts. Screw on and finger tighten coupling nuts on fittings, then using wrenches, tighten nuts 1/8 turn.

1. Working at front of air reservoirs (1) and using 13/16-inch wrench, screw on and tighten coupling nut (2).
2. Using 7/8-inch wrench, screw on and tighten coupling nut (3).

GO TO FRAME 4

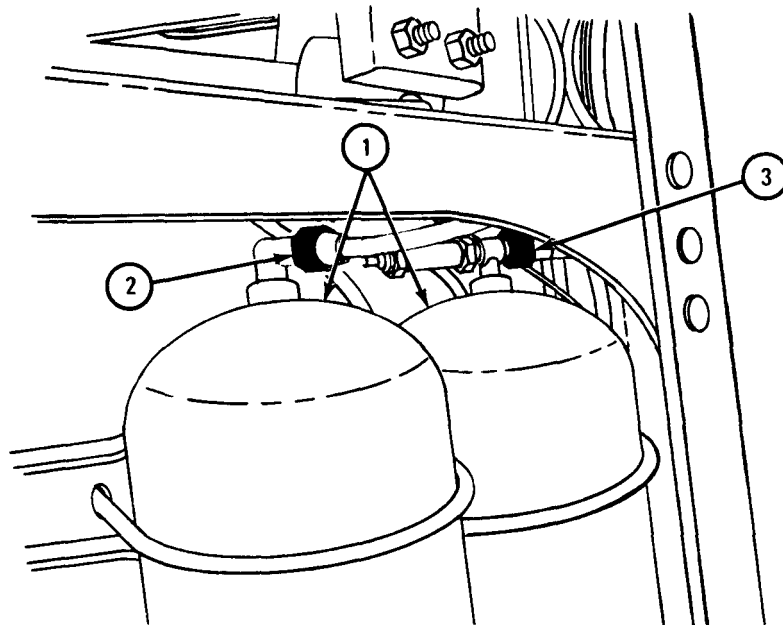

TA 101220

FRAME 4

CAUTION

Do not over tighten coupling nuts. Screw on and finger tighten coupling nuts on fittings, then using 13/16-inch wrench, tighten nuts 1/8 turn.

1. Put tube (1) with coupling nuts (2 and 3) in place. Using 13/16-inch wrench, screw on and tighten coupling nut (2).
2. Using 13/16-inch wrench, screw on and tighten coupling nut (3).

NOTE

Follow-on Maintenance Action Required:

1. Do air system leak test. Refer to Part 1, para 1-5.
2. Replace spare wheel. Refer to TM 9-2320-209-10.

END OF TASK

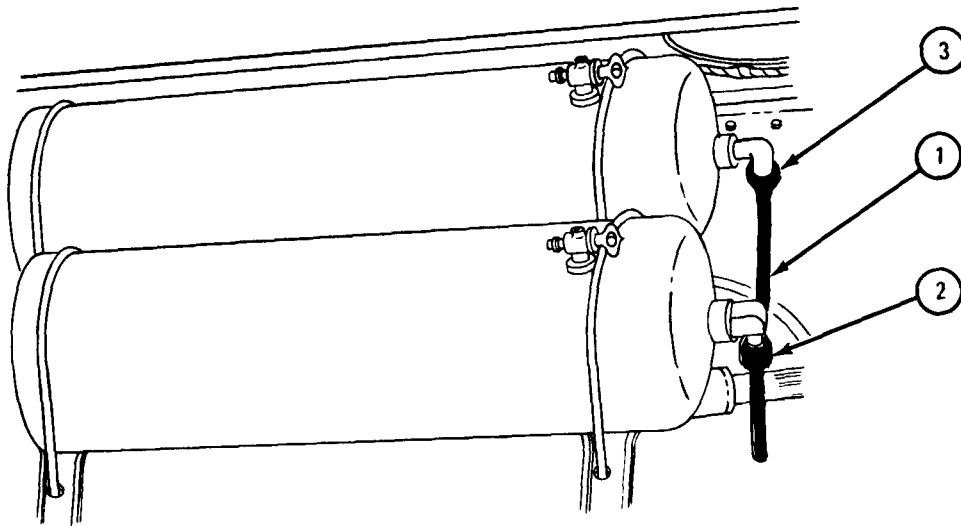

TA 101225

Section VII. COMPRESSED AIR SYSTEM

13-31. AIR COMPRESSOR REMOVAL AND REPLACEMENT.

TOOLS:	7/16-inch wrench	7/8-inch open end box wrench
	1/2-inch wrench	Air compressor pulley adjusting wrench, pn 10935288
	1 1/8-inch socket wrench	Mechanical puller
	11/16-inch wrench	Brass drift punch
	1 13/16-inch wrench	Light hammer
	9/16-inch open end box wrench	

SUPPLIES: Air compressor-to-support gasket
 Discharge housing gasket
 Air intake manifold gasket

PERSONNEL: One

EQUIPMENT CONDITION: Truck parked, engine off and cool, handbrake set.

a. Preliminary Procedures.

- (1) Vent air system pressure. Refer to para 13-20.
- (2) Remove air compressor drive belt. Refer to para 13-34.
- (3) Remove front engine oil filter. Refer to Part 1, para 2-5.

b. Removal.

WARNING

Make sure air compressor has cooled off before working on it. Air compressor gets very hot and may cause serious burns.

FRAME 1

1. Using 7/8-inch open end box wrench, unscrew and take off tube nut (1).
 2. Using 9/16-inch open end box wrench, unscrew and take off tube nut (2).
- GO TO FRAME 2

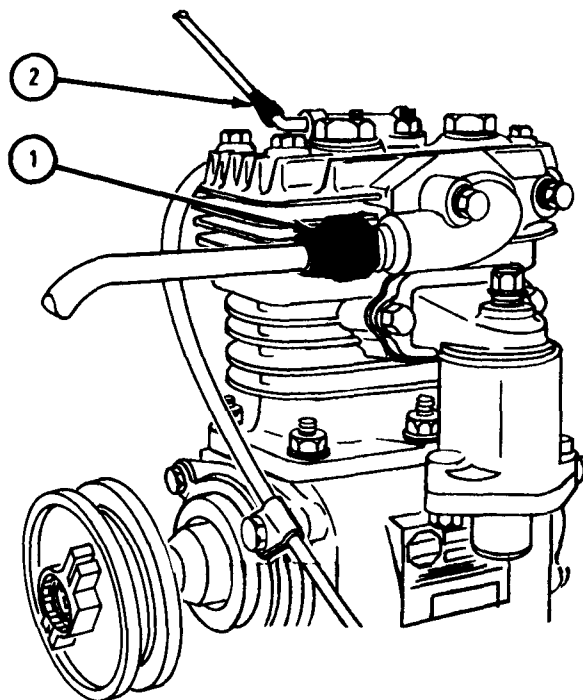
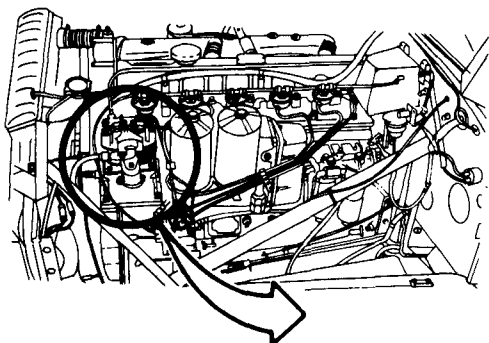

TA 084020

FRAME 2

1. Using 1/2-inch wrench, unscrew and take out capscrew (1). Take tube clamp (2) off air compressor (3) and screw capscrew back into air compressor.

NOTE

Some models may have brace (4). Other models may not.

2. Using 7/16-inch wrench, unscrew and take out capscrew (5). Take brace (4) off air compressor (3).
3. Using 11/16-inch wrench, unscrew and take off four nuts (6) and washers (7).
4. Take off tachometer cable bracket (8).
5. Take air compressor (3) and gasket (9) off air compressor support (10) and out of engine compartment. Throw away gasket.

GO TO FRAME 3

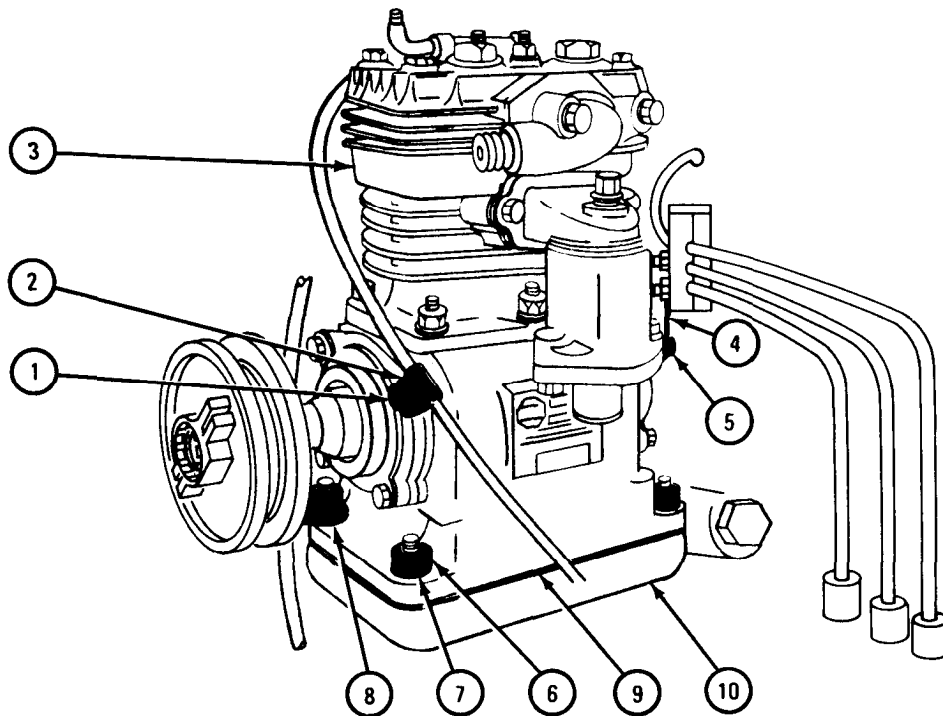

TA 084021

FRAME 3

1. Using 1 13/16-inch wrench, hold pulley (1). Using 1 1/8-inch socket wrench, unscrew and take off nut (2).
2. Using 9/16-inch open end wrench, unscrew and take out two capscrews (3) and lockwashers (4).
3. Using pulley adjusting wrench, unscrew and take off adjustable pulley flange (5).
4. Using mechanical puller, pull off pulley (1).

NOTE

Some models have key (6). Some models do not.

5. Using hammer and brass drift, tap out key (6).

GO TO FRAME 4

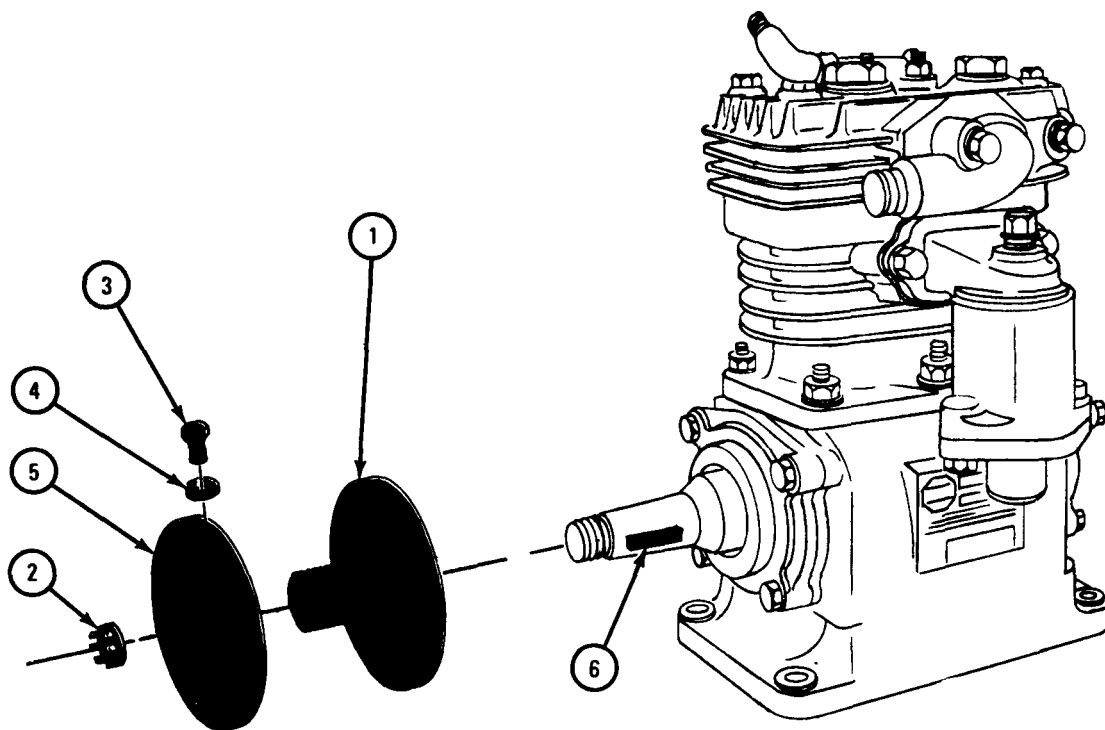

TA 088376

FRAME 4

1. Using 1/2-inch wrench, unscrew and take off two capscrews and washers (1), discharge housing (2), and gasket (3). Throw away gasket.
2. Using 1/2-inch wrench, unscrew and take off two capscrews and washers (4), intake air manifold (5), and gasket (6). Throw away gasket.

END OF TASK

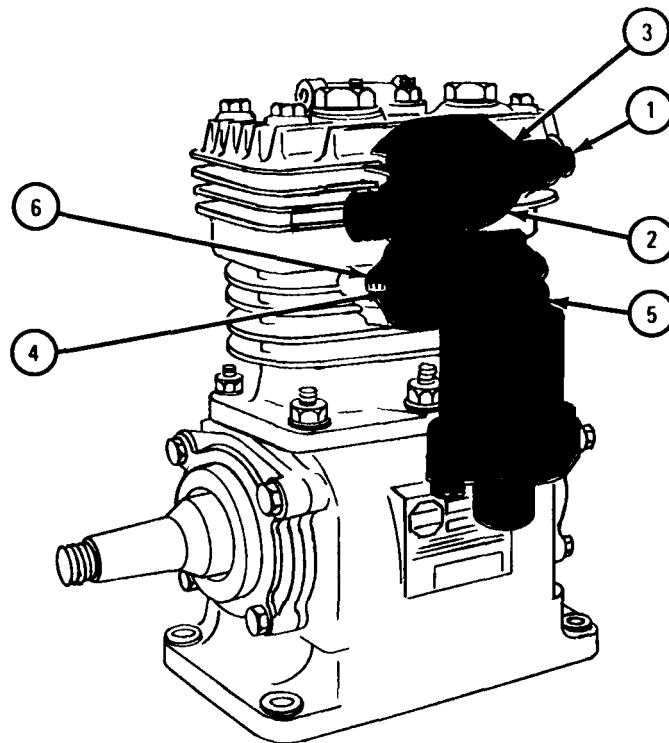

TA 084022

c. Replacement.

NOTE

If putting on the same air compressor that was taken off in para 13-31b, start with frame 2.
If putting on new air compressor, start with frame 1.

FRAME 1

NOTE

All replacement air compressors come with a protective cover, gasket, and slotted nut. Do not use this gasket or nut when putting air compressor on truck.

1. Using screwdriver, pry off four push-on nuts (1). Take off four rivets (2), protective cover (3), and gasket (4).
2. Unscrew and take off slotted nut (5). Throw away parts (1 through 5).

NOTE

Air compressor pulleys (6) come with or without keyways.

3. If pulley (6) does not have a keyway, using hammer and punch, take key (7) out of shaft (8).

GO TO FRAME 2

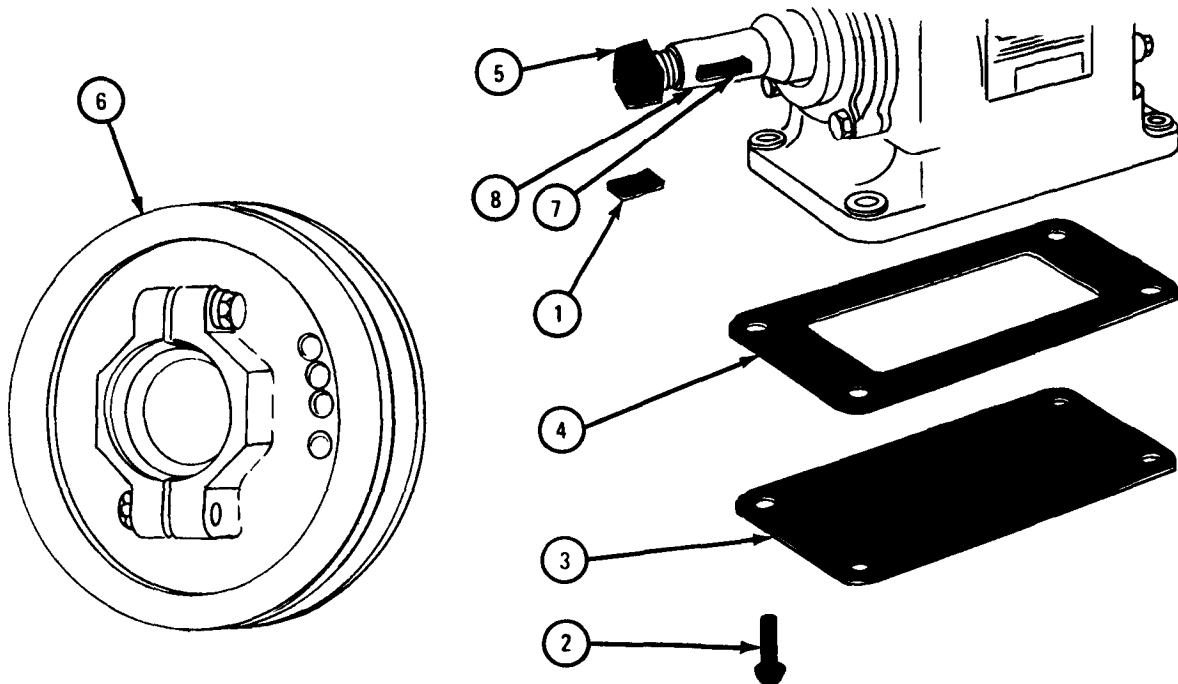

TA 084023

FRAME 2

1. Put intake air manifold (1) with gasket (2) on air compressor (3) as shown. Using 1/2-inch wrench, screw in and tighten two capscrews with washers (4).
2. Put air discharge housing (5) with gasket (6) on air compressor (3) as shown. Using 1/2-inch wrench, screw in and tighten two capscrews with washers (7).

GO TO FRAME 3

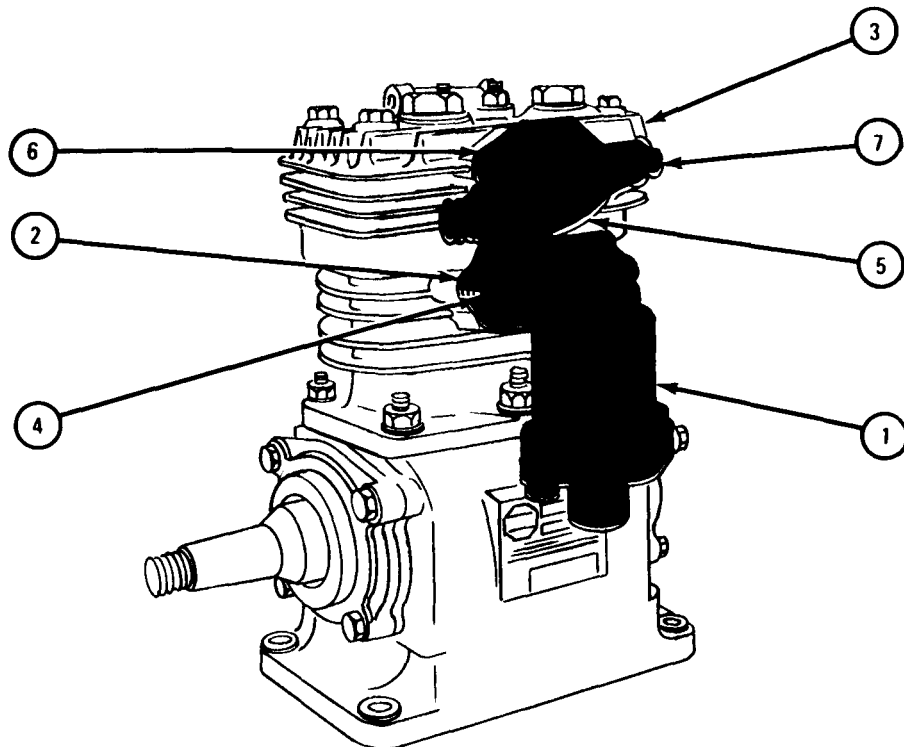

TA 084024

FRAME 3

1. Using hammer and brass drift, tap key (1) into shaft (2).
2. Aline keyway in pulley (3) with key (1) and put pulley on shaft (2).
3. Using 1 13/16-inch wrench, hold pulley (3). Using 1 1/8-inch socket wrench, screw on and tighten nut (4).
4. Using pulley adjusting wrench, screw on adjustable pulley flange (5).
5. Using 9/16-inch open end wrench, screw on and tighten two capscrews (6) with lockwashers (7).

GO TO FRAME 4

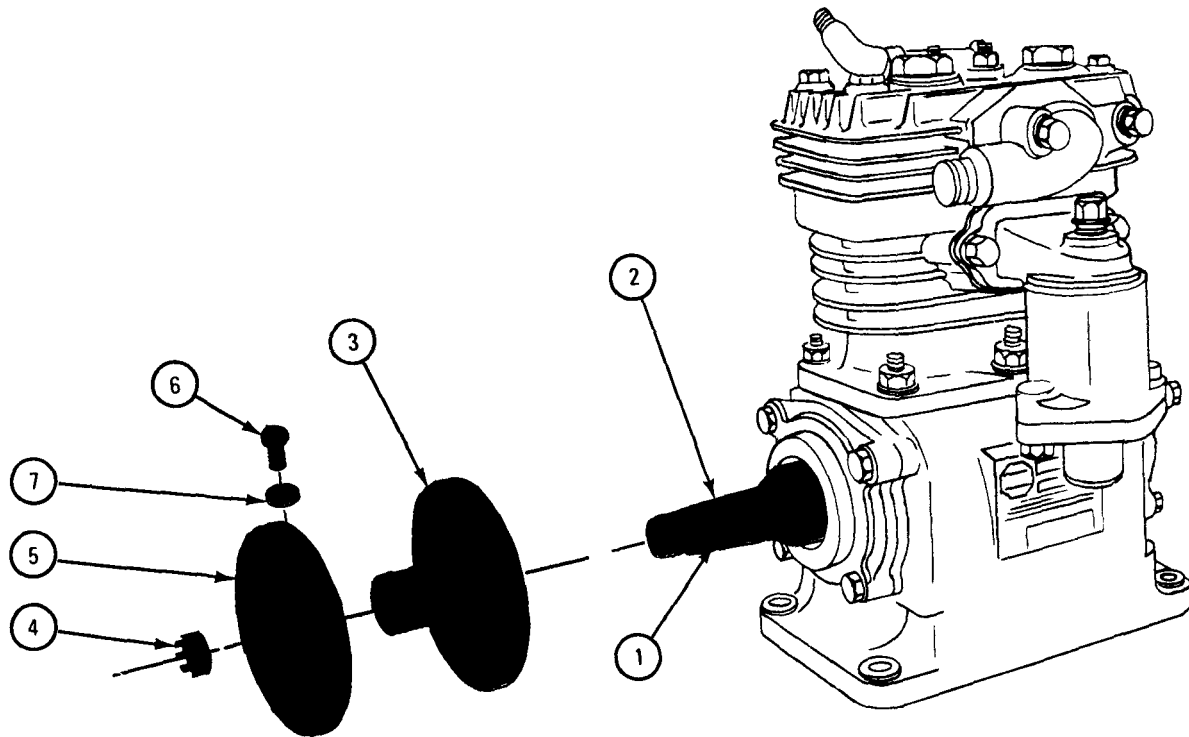

TA 088577

FRAME 4

1. Put gasket (1) and air compressor (2) on four studs in air compressor support (3).
2. Put tachometer cable bracket (4) on stud (5) as shown.
3. Using 11/16-inch wrench, screw on and tighten four washers (6) and nuts (7).
4. Using 7/16-inch wrench, unscrew and take out capscrew (8). Put capscrew through tube clamp (9) and using 7/16-inch wrench, screw in and tighten capscrew.

GO TO FRAME 5

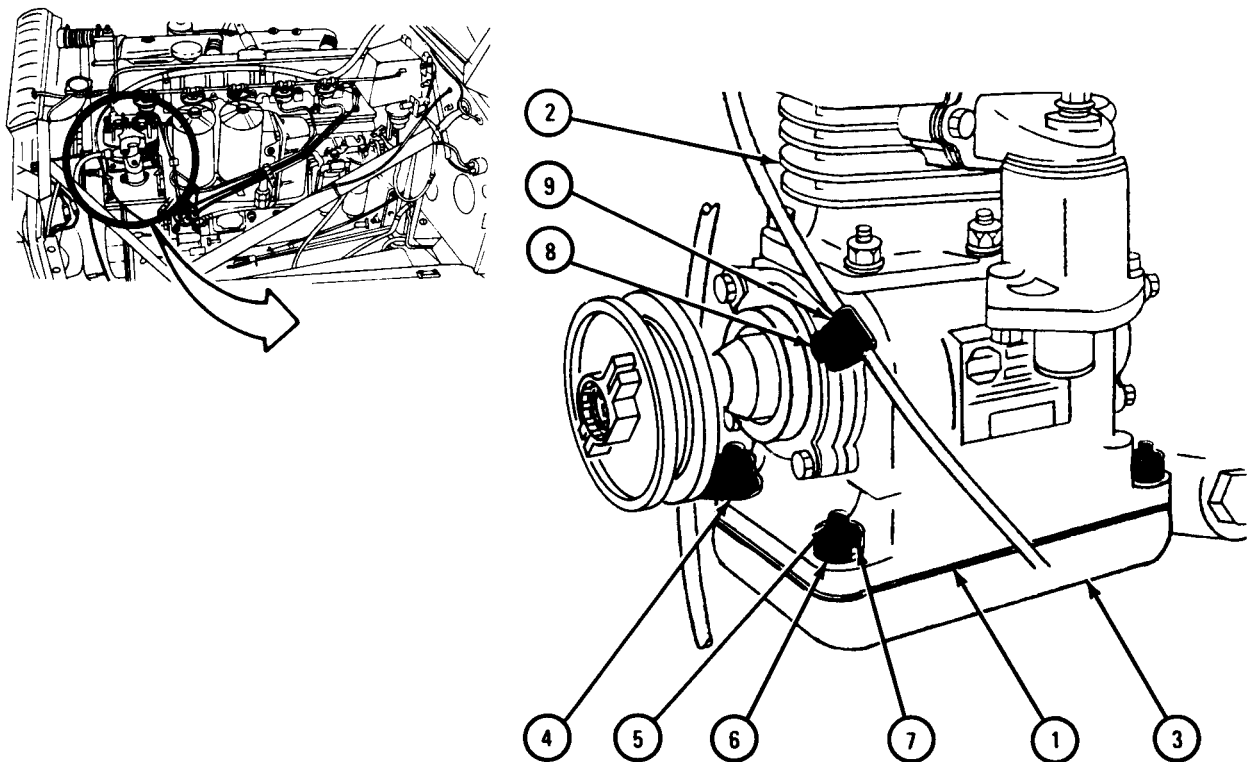

TA 084025

FRAME 5

NOTE

Some models have brace (1). Others do not.

1. Put brace (1) into place and align screw holes.
2. Using 7/16-inch wrench, screw in and tighten capscrew (2).
3. Using 7/8-inch open end box wrench, screw on and tighten tube nut (3).
4. Using 9/16-inch open end box wrench, screw on and tighten tube nut (4).

NOTE

Follow-on Maintenance Action Required:

1. Replace air compressor drive belt. Refer to para 13-34.
2. Do air system leak test. Refer to Part 1, para 1-5.
3. Replace front engine oil filter. Refer to Part 1, para 2-5.

END OF TASK

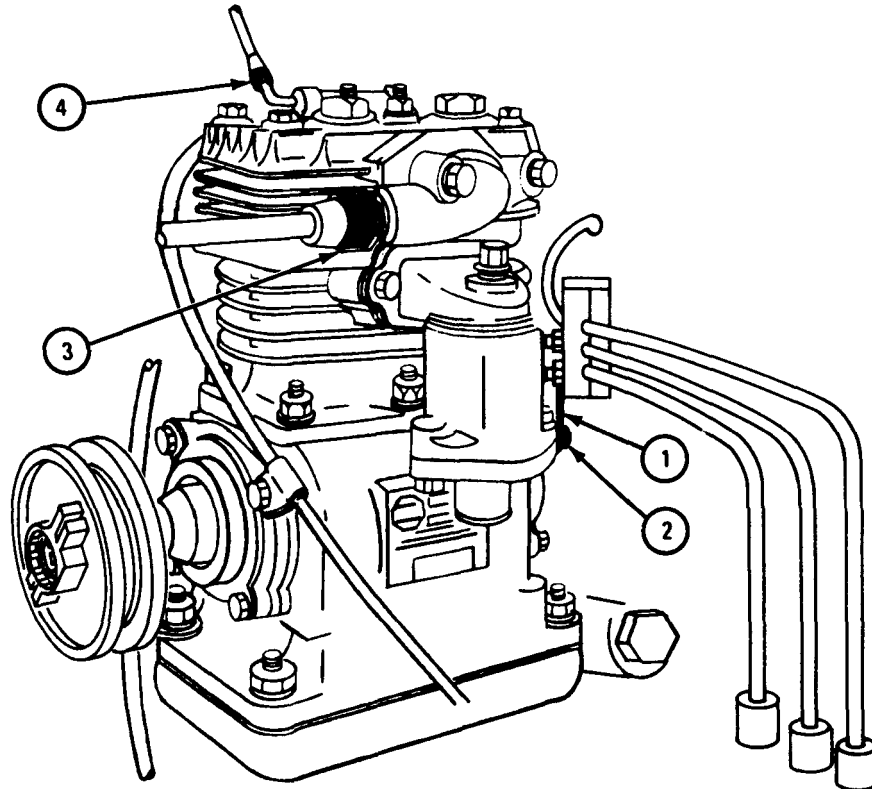

TA 084026

13-32. AIR COMPRESSOR SERVICE.

TOOLS: 1/2-inch wrench
Eye shields

SUPPLIES: Air compressor intake manifold gasket
Solvent, dry cleaning, type II (SD-2), Fed. Spec P-D-680
Compressed air source, 30 psi max

PERSONNEL: One

EQUIPMENT CONDITION: Truck parked, engine off, handbrake set.

a. Preliminary Procedure. Open hood and left side panel. Refer to TM 9-2320-209-10.

b. Removal.

FRAME 1

1. Using wrench, loosen two capscrews (1).
2. Using wrench, unscrew and take out two capscrews (2) and take off manifold (3) and gasket (4). Throw away gasket.

END OF TASK

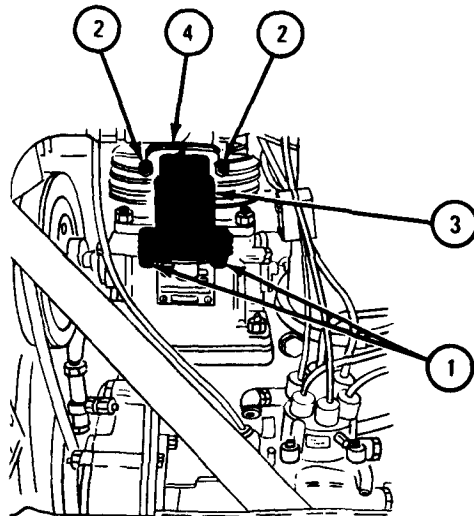
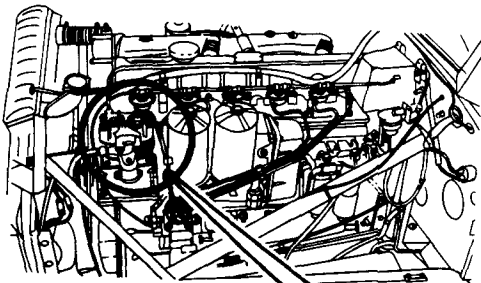

TA 084056

c. Disassembly and Service.

FRAME 1

1. Using wrench, unscrew and take out two capscrews (1).
2. Take off cap (2) and take out spring (3), plate (4), and strainer (5).

WARNING

Dry cleaning solvent is flammable. Do not use near an open flame. Keep a fire extinguisher nearby when solvent is used. Use only in well-ventilated places. Failure to do this may result in injury to personnel and damage to equipment.

Eye shields must be worn when using compressed air. Eye injury can occur if eye shields are not used.

3. Using solvent, wash strainer (5). Blow compressed air through strainer to make sure it is clean.

END OF TASK

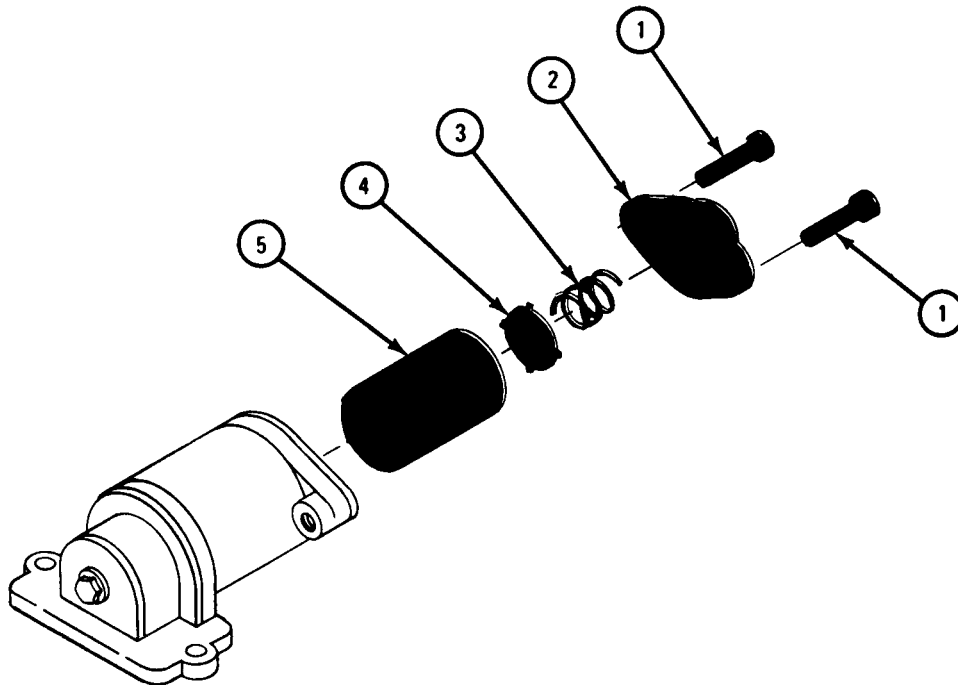

TA 084057

d. Assembly.

FRAME 1

1. Put strainer (1), plate (2), and spring (3) into manifold (4).
2. Put cap (5) onto manifold (4) and align screw holes.
3. Using wrench, screw in two capscrews (6). Final tightening of these capscrews will be done on truck.

END OF TASK

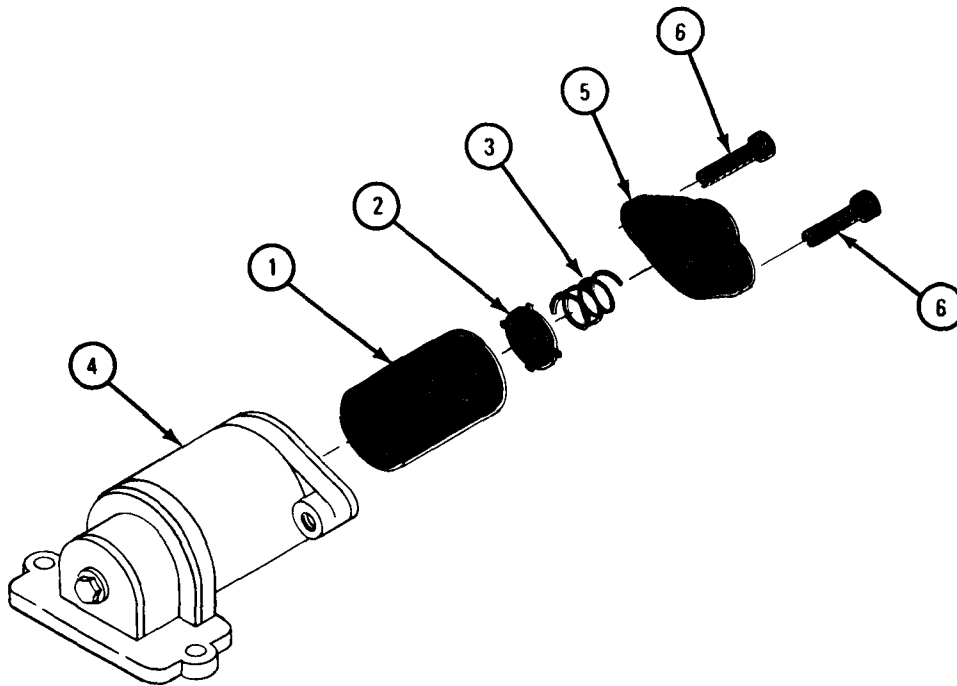

TA 084058

e. Replacement.

FRAME 1

1. Put manifold (1) with gasket (2) in place on compressor (3).
2. Using wrench, screw in and tighten two capscrews (4) and tighten two capscrews (5).

NOTE

Follow-on Maintenance Action Required:

Close hood and left side panel. Refer to TM 9-2320-209-10.

END OF TASK

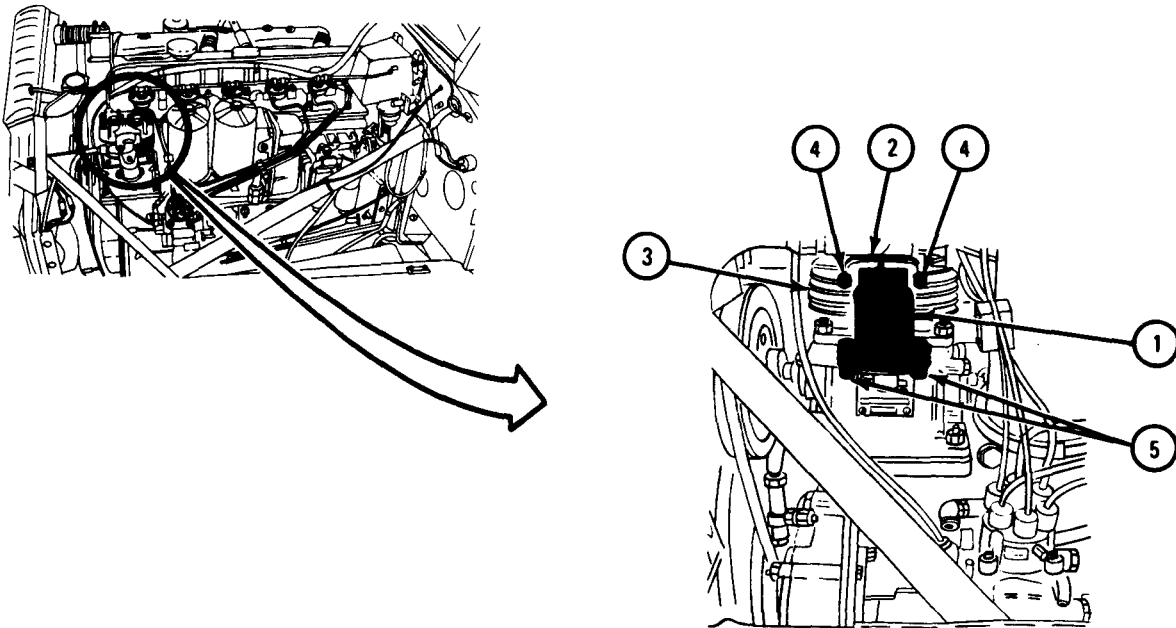

TA 084059

13-33. AIR COMPRESSOR DRIVE BELT AND PULLEY REMOVAL AND REPLACEMENT.

TOOLS: 9/16-inch socket wrench Pulley puller
 1 1/8-inch socket wrench 24-inch straight edge
 Air compressor pulley 6 - inch ruler
 wrench, pn 10935288

SUPPLIES: Masking tape, PPP-T-42C

PERSONNEL: One

EQUIPMENT CONDITION: Truck parked, engine off, handbrake set.

a. Preliminary Procedures.

- (1) Remove brush guard. Refer to Part 1, para 6-4.
- (2) Remove radiator. Refer to Part 1, para 6-3.

b. Removal.

NOTE

Air compressor pn M5407B has a tapered shaft with no key. Air compressor pn M5408D has a straight shaft with a key.

FRAME 1

1. Open hood. Refer to TM 9-2320-209-10.
2. Using air compressor pulley wrench, hold pulley flange (1). Using 1 1/8-inch socket wrench, unscrew nut (2).
3. Using 9/16-inch socket wrench, loosen screws (3 and 4) until lockwashers (5 and 6) do not hold.
4. Using air compressor pulley wrench, unscrew pulley flange (1) until drive belt (7) is loose enough to take off. Take drive belt off pulley (8).
5. Using pulley puller, pull pulley (8) off shaft of compressor (9).

GO TO FRAME 2

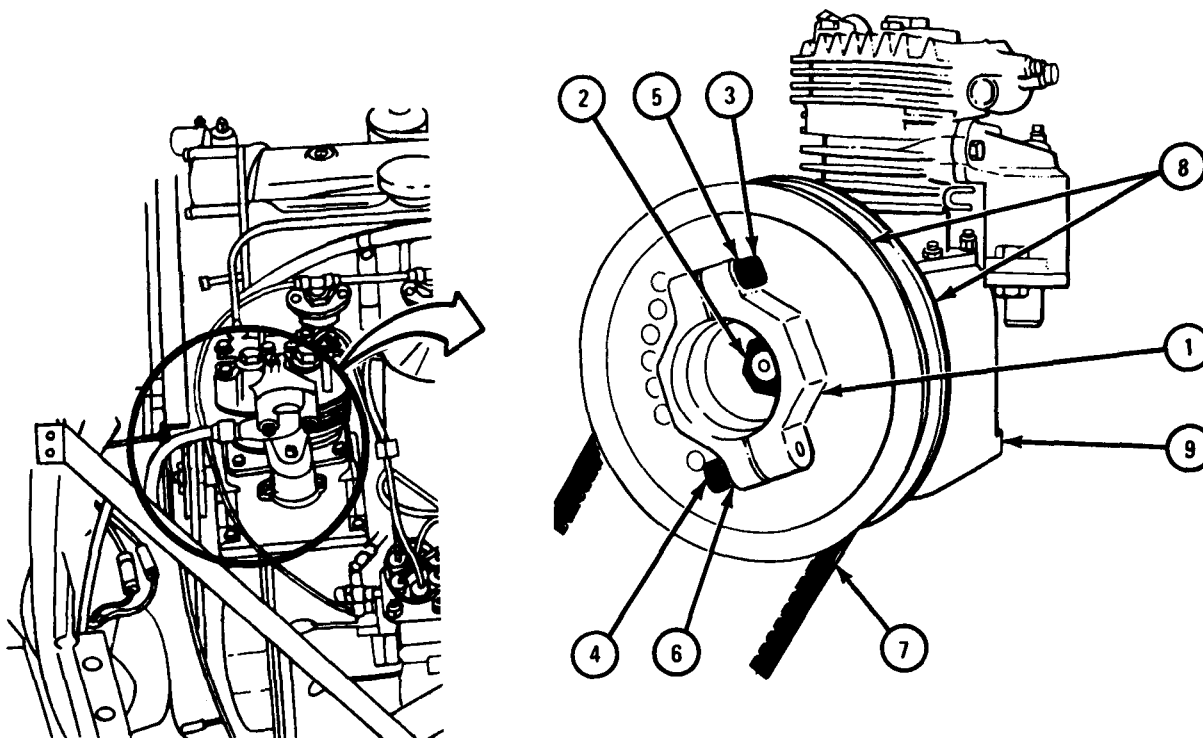

TA 046173

FRAME 2

1. Screw nut (1) onto compressor drive shaft (2).
2. Using tape (3), hold woodruff key (4) onto compressor shaft (2).

END OF TASK

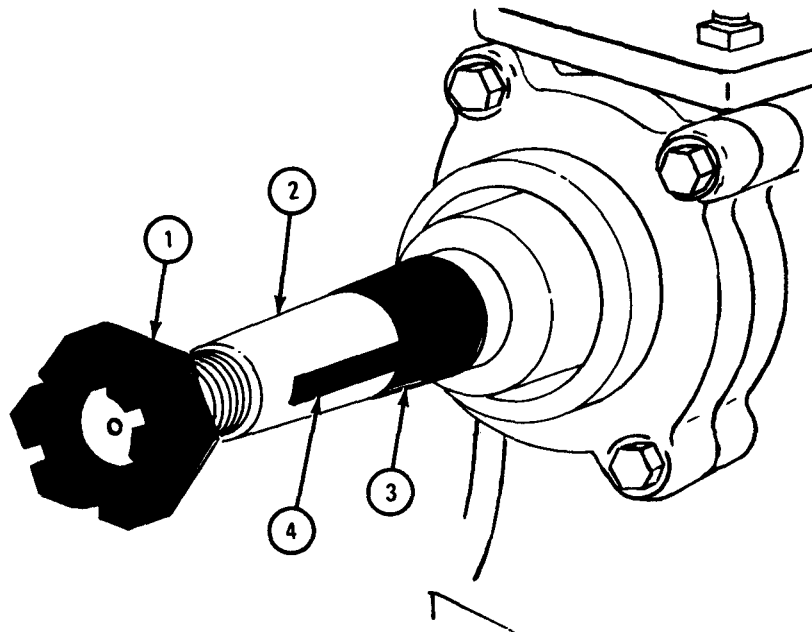

TA 046174

c. Replacement.

FRAME 1

1. Screw pulley flange (1) into pulley flange (2).
 2. Using 9/16-inch wrench, tighten screws (3 and 4).
- GO TO FRAME 2

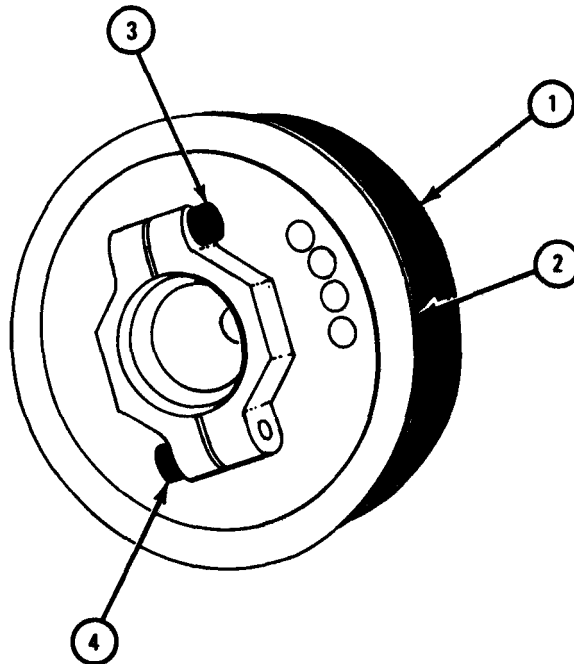

TA 046175

FRAME 2

1. Unscrew nut (1) from compressor drive shaft (2).
2. Take away tape (3) holding woodruff key (4) onto compressor drive shaft (2).

GO TO FRAME 3

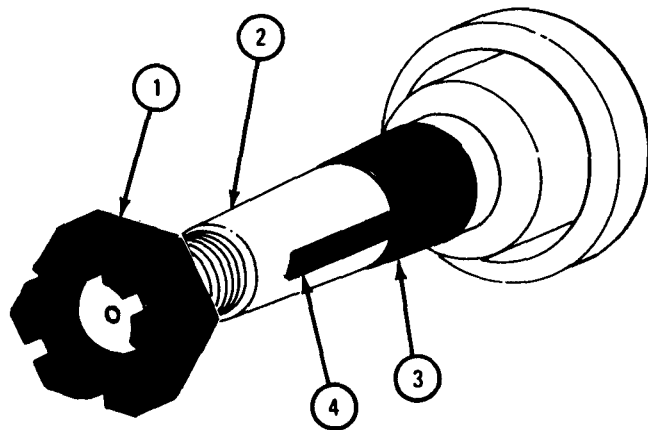
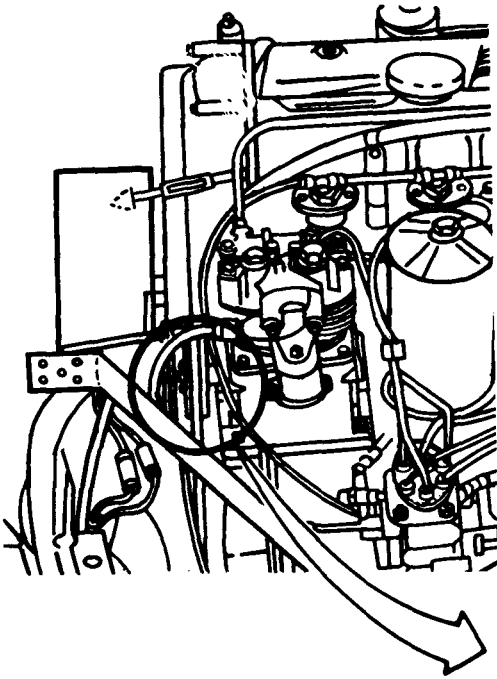

TA 046233

FRAME 3

1. Put pulley (1) onto compressor drive shaft (2) making sure that woodruff key (3) is in pulley keyway.
2. Using air compressor pulley wrench, hold pulley flange (4). Using 1 1/8-inch socket wrench, screw on nut (5).
3. Using 9/16-inch socket wrench, loosen two screws (6) until lockwashers (7) do not hold.
4. Put drive belt (8) on lower pulley (9).
5. Unscrew pulley flange (4) until drive belt (8) can be put on pulley (1).

GO TO FRAME 4

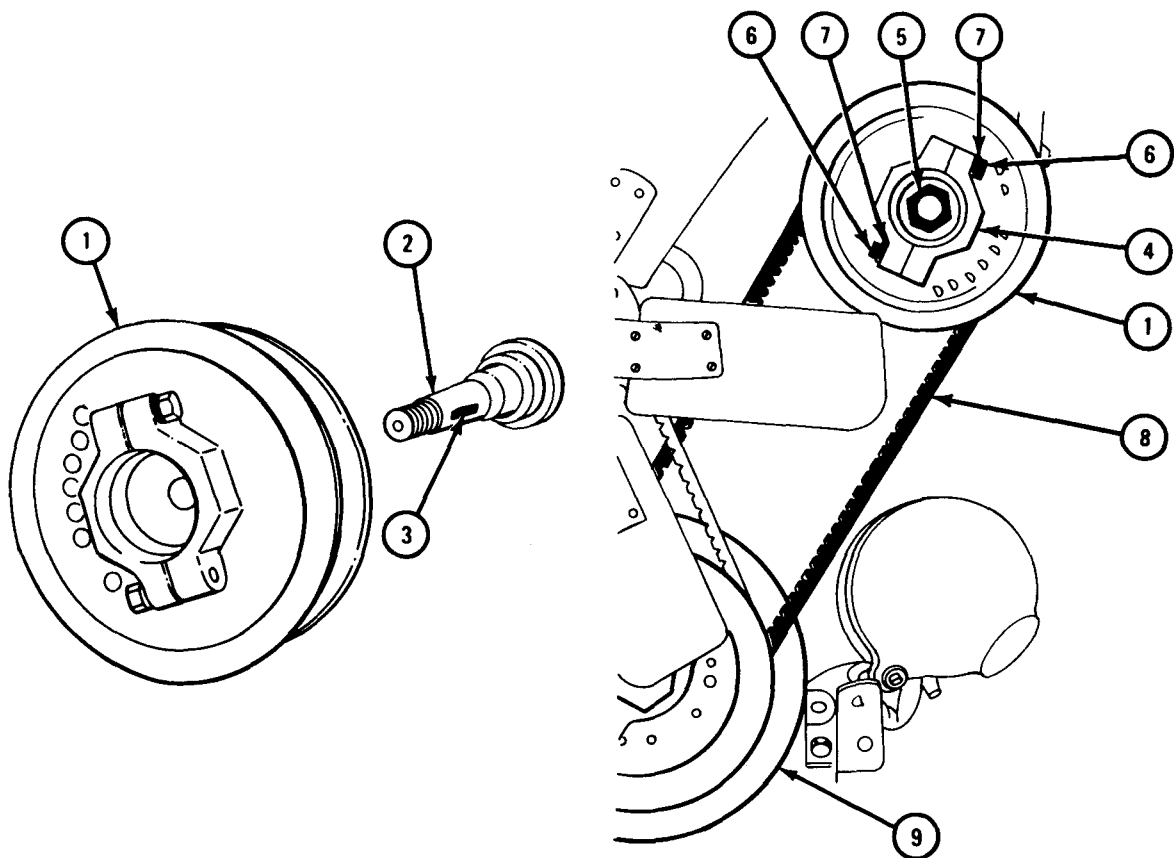

TA 046176

FRAME 4

1. Hold straight edge (1) against drive belt (2). Using finger pressure and 6-inch ruler (3), push against center of drive belt.
2. Using air compressor pulley wrench, screw on pulley flange (4) until 6-inch ruler measures one inch to straight edge.
3. Using 9/16-inch socket wrench, tighten screws (5 and 6).

NOTE

Follow-on Maintenance Action Required:

1. Replace radiator. Refer to Part 1, para 6-3.
2. Replace brush guard. Refer to Part 1, para 6-4.

END OF TASK

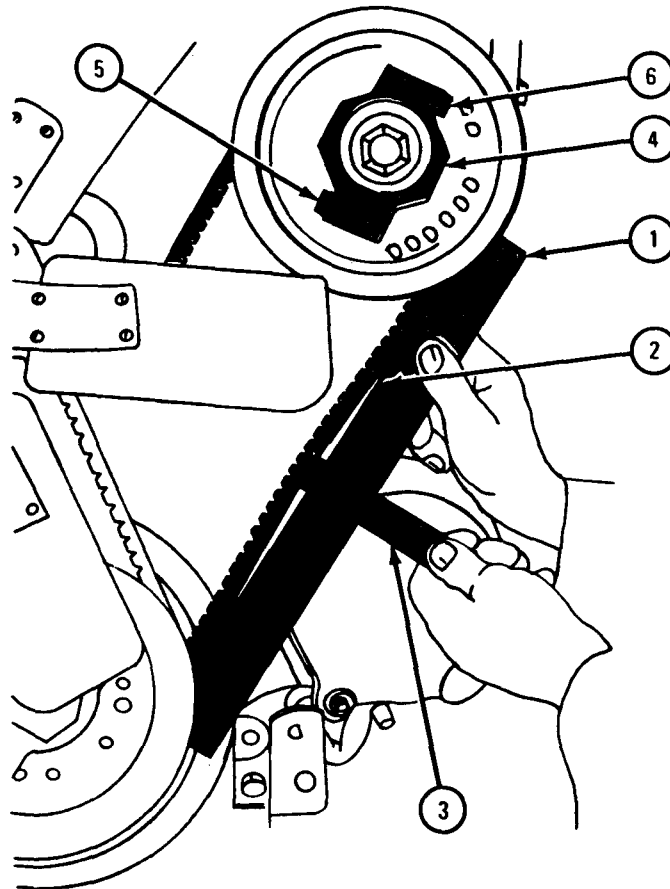

TA 046177

13-34. AIR COMPRESSOR DRIVE BELT REMOVAL, REPLACEMENT, AND ADJUSTMENT.

TOOLS: 9/16-inch socket wrench
10-inch extension
24-inch adjustable
Air compressor pulley adjusting wrench, pn 10935288
Straight edge
Ruler

SUPPLIES: None

PERSONNEL: One

EQUIPMENT CONDITION: Truck parked, engine off, handbrake set.

- a. Preliminary Procedure. Remove fan drive belts. Refer to Part 1, para 6-9.
- b. Removal.

FRAME 1

1. Using socket wrench, unscrew and take out two capscrews (1).
2. Using air compressor pulley adjusting wrench (2), turn adjusting flange (3) to the left.
3. Take off air compressor drive belt (4) from air compressor pulley (5) and crankshaft pulley (6).

END OF TASK

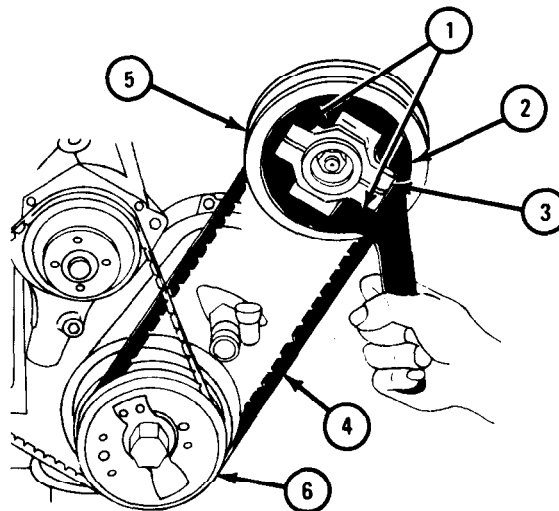
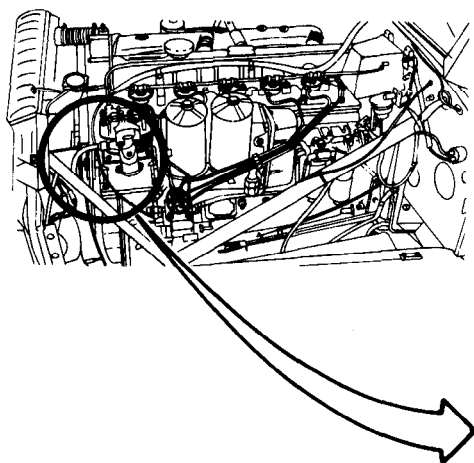

TA 047641

c. Replacement and Adjustment.**FRAME 1**

1. Place air compressor drive belt (1) on air compressor pulley (2) and on inner groove of crankshaft pulley (3).
2. Grasp air compressor drive belt (1) on each side of air compressor pulley (2) and lift air compressor drive belt (1) up.
3. Turn adjusting flange (4) to the right as far as you can. Let go of air compressor drive belt (1).
4. Using adjustable wrench, hold nut behind air compressor pulley (2). Using air compressor pulley adjusting wrench (5), turn adjusting flange (4) to the right until there is no slack in air compressor drive belt (1).
5. Push on air compressor drive belt (1) at point midway between air compressor pulley (2) and crankshaft pulley (3). Air compressor drive belt (1) should give about 1/2 inch at this point.
6. Using air compressor pulley adjusting wrench (5), turn adjusting flange (4) to right or left until air compressor drive belt (1) gives about 1/2 inch.
7. Using 9/16-inch socket wrench with extension, screw in and tighten two screws (6).

NOTE

Follow-on Maintenance Action Required:

Replace fan drive belts. Refer to Part 1, para 6-9.

END OF TASK

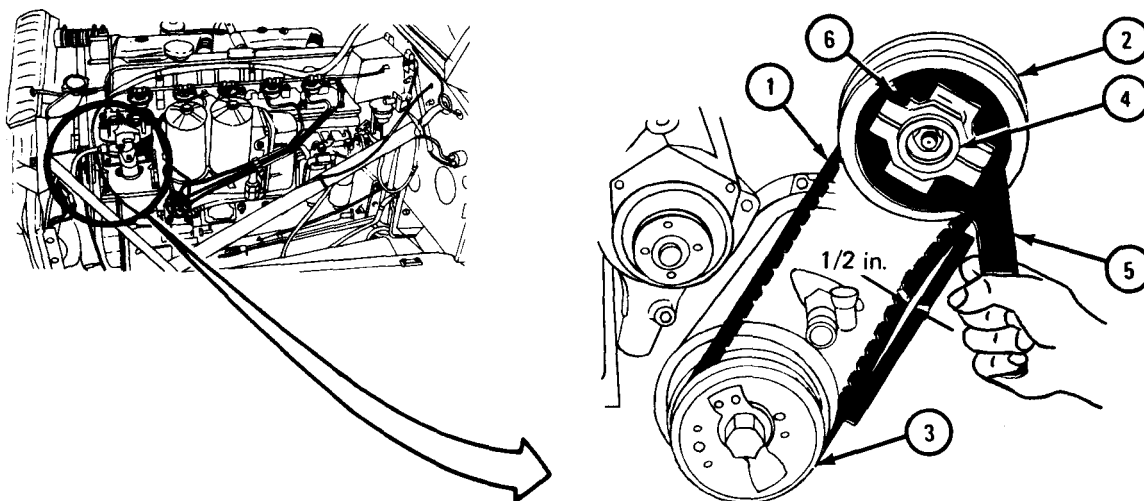

TA 047642

13-35. AIR COMPRESSOR GOVERNOR ASSEMBLY REMOVAL AND REPLACEMENT.

- TOOLS: 7/16-inch wrench
9/16-inch wrench
5/8-inch wrench
1/2-inch socket wrench
5-inch extension
Adjustable wrench
3/16-inch sockethead screw key (Allen wrench or equivalent)

SUPPLIES: None

PERSONNEL: One

EQUIPMENT CONDITION: Truck parked, engine off, handbrake set.

a. Preliminary Procedures.

- (1) Open hood and right side panel. Refer to TM 9-2320-209-10.
- (2) Vent air system. Refer to para 13-20.

b. Removal.

FRAME 1

1. Using 5/8-inch wrench, unscrew and take off two tube nuts (1).
2. Using 9/16-inch wrench, unscrew and take off tube nut (2).
3. Using 1/2-inch socket wrench and 5-inch extension, unscrew and take out two capscrews (3) and lockwashers (4).
4. Take off air compressor governor valve (5).

GO TO FRAME 2

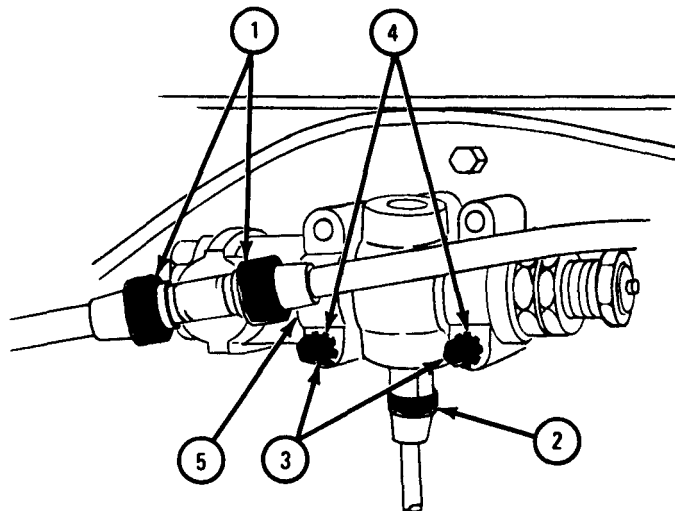
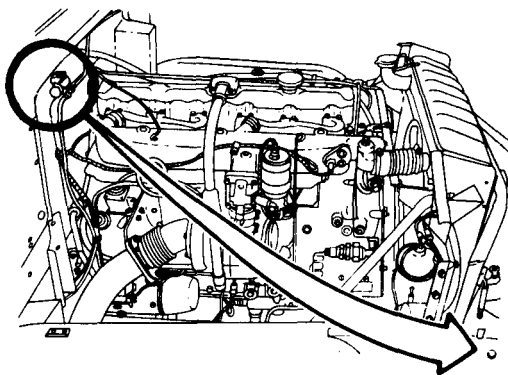

TA 046356

FRAME 2

1. Using adjustable wrench, carefully unscrew and take off tee fitting (1).
2. Using 7/16-inch wrench, unscrew and take off straight fitting (2).
3. Using 3/16-inch allen wrench, unscrew and take out pipe plug (3).

END OF TASK

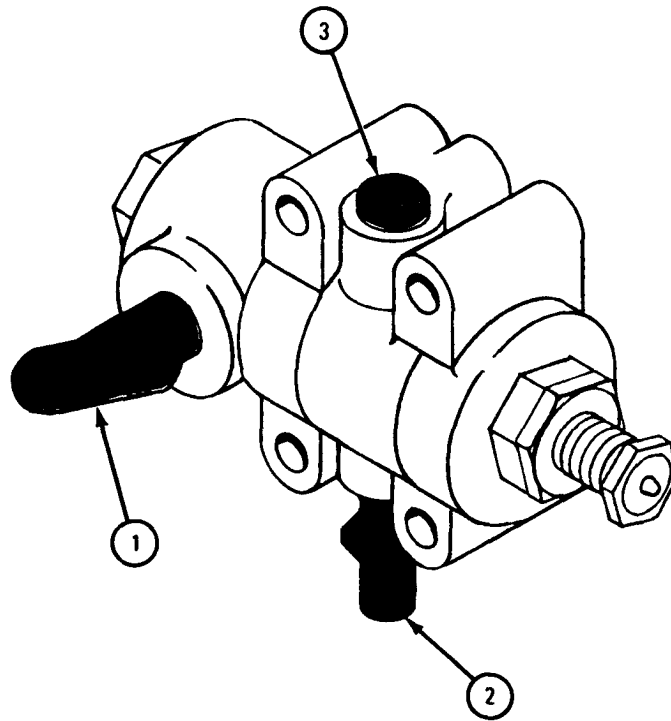

TA 046453

c. Replacement.

FRAME 1

1. Using adjustable wrench, screw in and tighten tee fitting (1).
2. Using 7/16-inch wrench, screw in and tighten straight fitting (2).
3. Using 3/16-inch allen wrench, screw in and tighten pipe plug (3).

GO TO FRAME 2

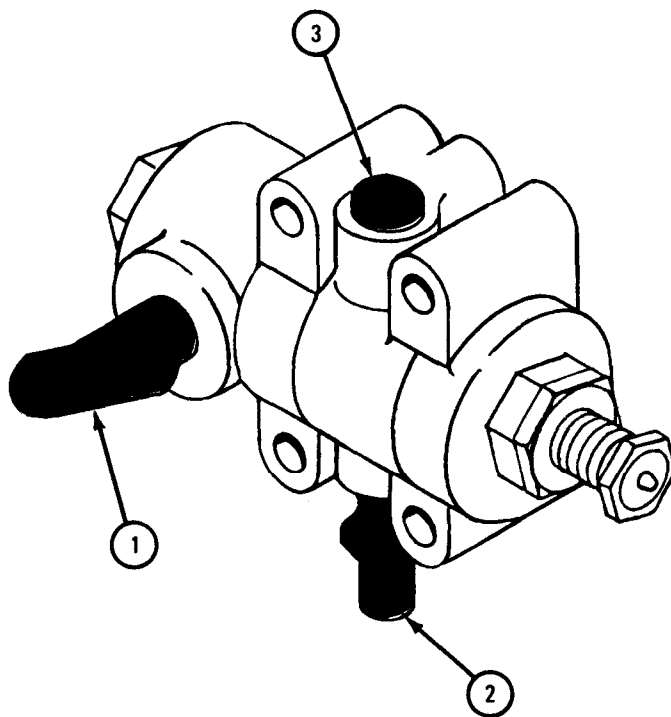

TA 046453

FRAME 2

1. Aline screw holes in air compressor governor assembly (1) with firewall (2).
2. Using 1/2-inch socket wrench and 5-inch extension, screw in and tighten two capscrews (3) and lockwashers (4).
3. Using 5/8-inch wrench, screw on and tighten two tube nuts (5).
4. Using 9/16-inch wrench, screw on and tighten tube nut (6).

NOTE**Follow-on Maintenance Action Required:**

1. Close hood and right side panel. Refer to TM 9-2320-209-10.
2. Adjust air compressor governor. Refer to para 13-36.

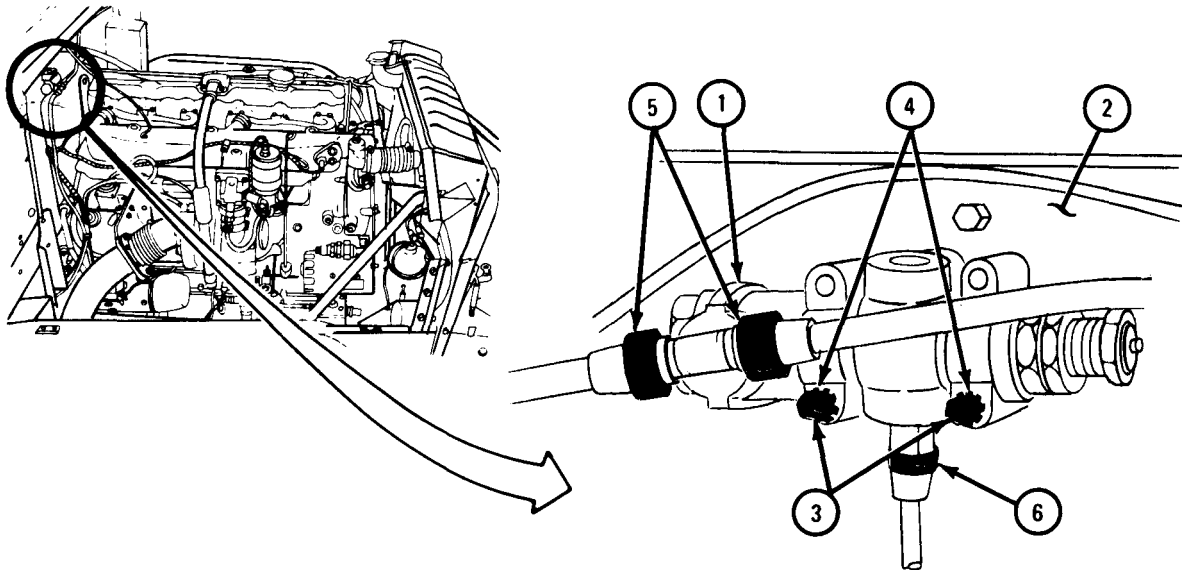
END OF TASK

TA 046358

13-36. AIR COMPRESSOR GOVERNOR PRESSURE CHECK AND ADJUSTMENT.

TOOLS: 1 1/16-inch wrench
13/16-inch wrench

SUPPLIES: None

PERSONNEL: Two

EQUIPMENT CONDITION: Truck parked, engine off, handbrake set.

a. Pressure Check.

FRAME 1

1. Start engine and bring it to normal operating temperature. Refer to TM 9-2320-209-10.
2. Air pressure gage (1) reading should be 100 to 105 psi.
3. If air pressure gage (1) reading is correct, shut off engine. Refer to TM 9-2320-209-10.
4. If air pressure gage (1) is too high, stop engine. Refer to TM 9-2320-209-10. Do adjustment. Refer to para 13-36b.
5. If air pressure gage (1) reading is too low, stop engine. Refer to TM 9-2320-209-10. Do adjustment. Refer to para 13-36c.

END OF TASK

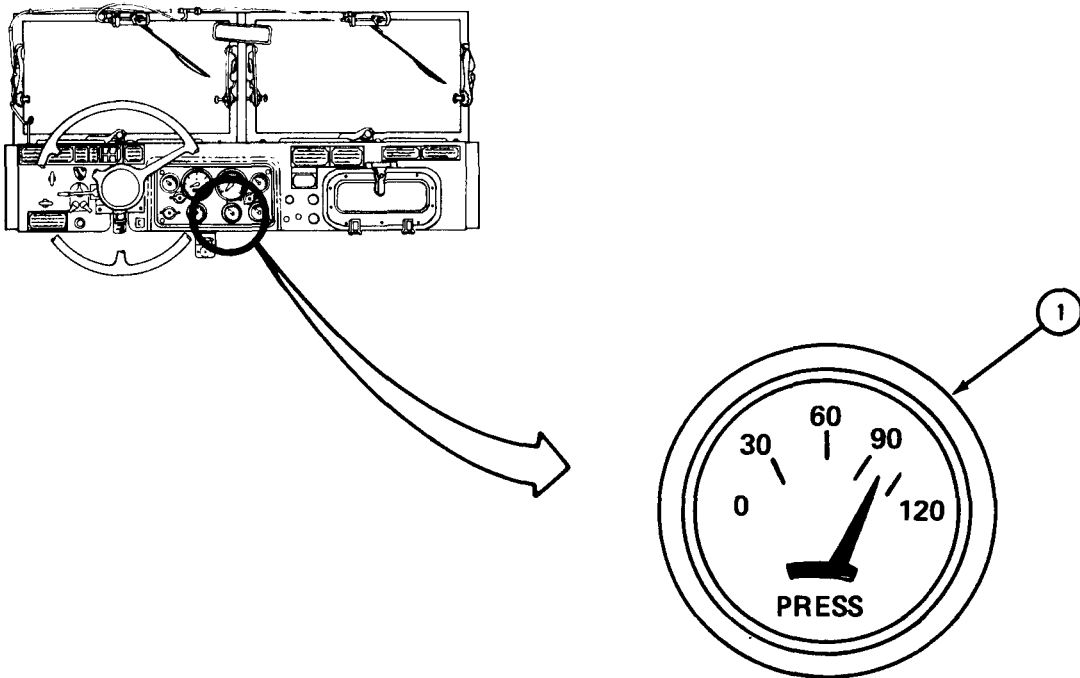

TA 047531

b . Adjustment (Air Pressure More Than 105 psi).

FRAME 1

- Soldier A 1. Open hood. Refer to TM 9-2320-209-10.
- Soldier B 2. Unscrew and take cap (1) off air valve (2). Watching air pressure gage (3), turn valve to left and bleed air pressure down below 100 psi. Turn valve to right. Tell soldier A when ready.
- Soldier A 3. Using 1 1/16-inch wrench, loosen jamnut (4).
4. Using 13/16-inch wrench, turn adjusting nut (5) 1/4 turn to left to lower air pressure. Tell soldier B when ready.
- Soldier B 5. Start engine and run until air pressure gage (3) stops going up and read gage. Refer to TM 9-2320-209-10.
6. If gage reads more than 105 psi, stop engine and do step 4 again.
7. If air pressure gage (3) reads between 100 and 105 psi, stop engine. Refer to TM 9-2320-209-10. Screw cap (1) on air valve (2).
- Soldier A 8. Using 1 1/16-inch wrench, tighten jamnut (4). Make sure that nut (5) does not turn.
9. Close hood. Refer to TM 9-2320-209-10.

END OF TASK

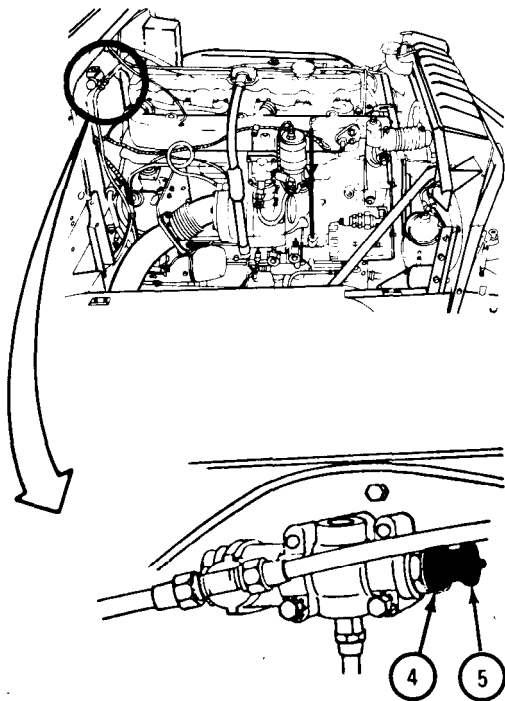

SOLDIER A

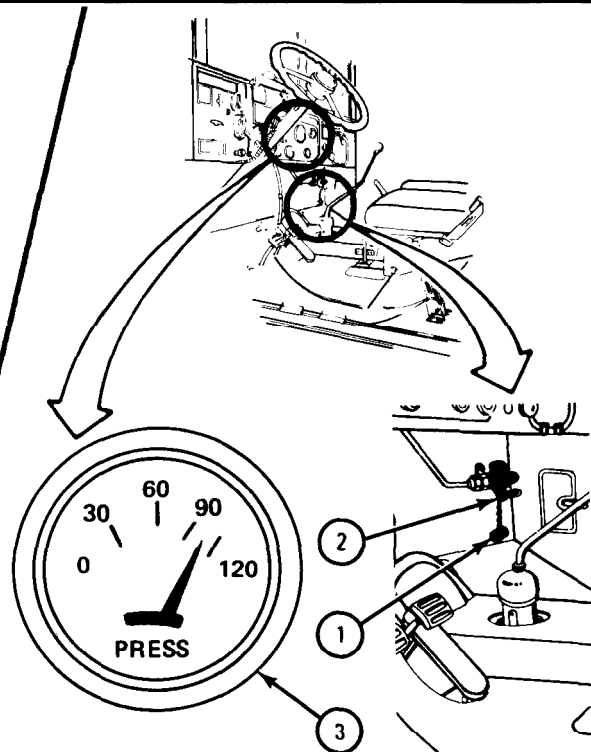

SOLDIER B

TA 046359

c. Adjustment (Air Pressure Less Than 105 psi).

FRAME 1

- Soldier A
1. Open hood. Refer to TM 9-2320-209-10.
 2. Using 1 1/16-inch wrench, loosen jamnut (1).
 3. Using 13/16-inch wrench, turn adjusting nut (2) 1/4 turn to right to raise air pressure. Tell soldier B when ready.
- Soldier B
4. Start engine and run until air pressure gage (3) stops going up and read gage. Refer to TM 9-2320-209-10.
 5. If gage reads less than 100 psi, stop engine and do step 3 again. Refer to TM 9-2320-209-10.
 6. If air pressure gage (3) reads between 100 and 105 psi, stop engine. Refer to TM 9-2320-209-10.
- Soldier A
7. Using 1 1/16-inch wrench, tighten jamnut (1). Make sure that adjusting nut (2) does not turn.
 8. Close hood. Refer to TM 9-2320-209-10.

END OF TASK

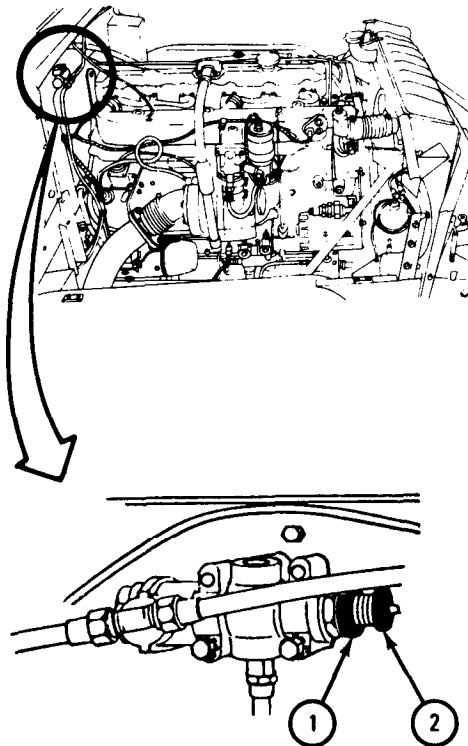

SOLDIER A

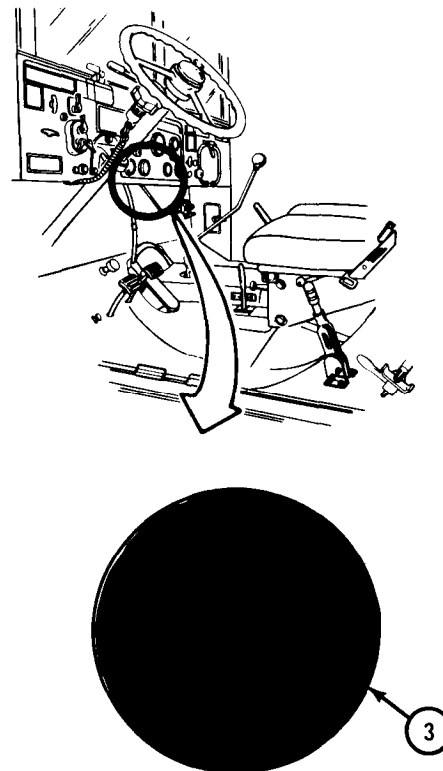

SOLDIER B

TA 080958

Section VIII. TRAILER BRAKE CONNECTIONS

13-37. QUICK-DISCONNECT COUPLING HALF REMOVAL AND REPLACEMENT.

TOOLS: 15-inch adjustable wrench (2)
 Cross-tip screwdriver (Phillips type)

SUPPLIES: None

PERSONNEL: One

EQUIPMENT CONDITION: Truck parked, engine off, handbrake set.

a. Preliminary Procedures.

(1) Vent air system. Refer to para 13-20.

(2) Remove dummy coupling. Refer to TM 9-2320-209-10.

b. Removal.

FRAME 1

1. Using screwdriver, unscrew and take out two screws (1). Take off cover (2).
2. Using adjustable wrenches, hold nut (3) and unscrew and take off quick-disconnect coupling (4).

END OF TASK

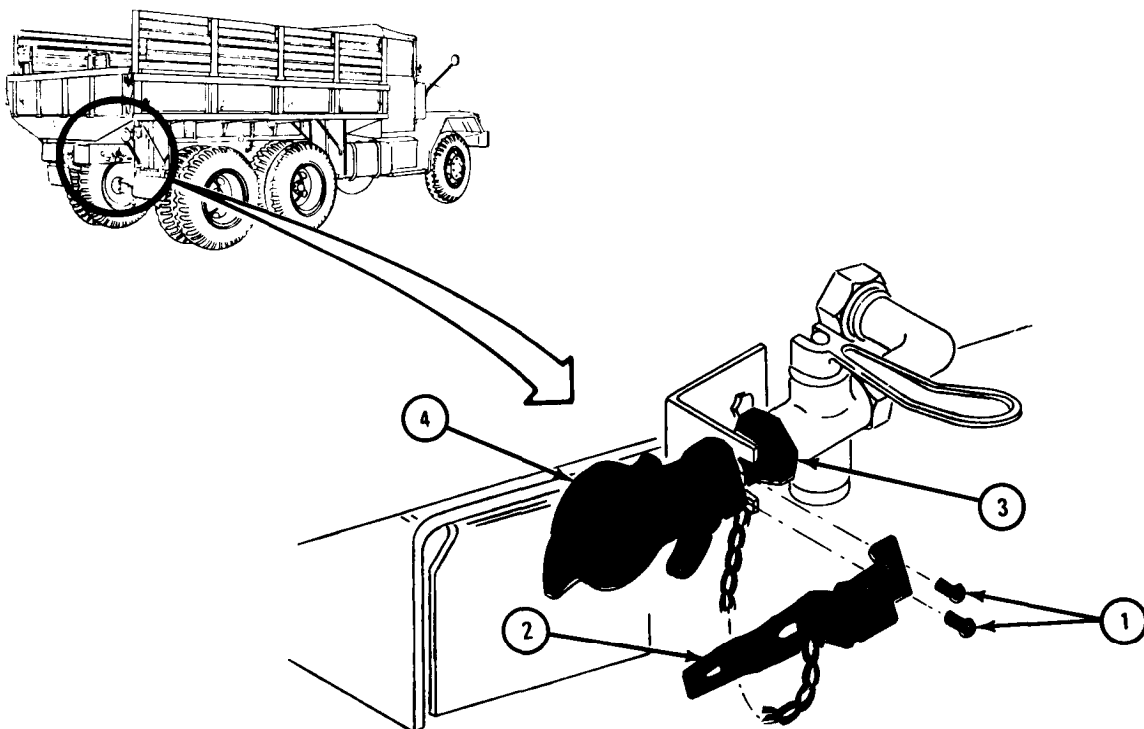

TA 046370

c. Replacement.

FRAME 1

1. Put quick-disconnect coupling (1) in place.
2. Using adjustable wrenches, hold nut (2) and screw in and tighten quick-disconnect coupling (1).
3. Put cover (3) in place.
4. Using screwdriver, screw in and tighten two screws (4).

NOTE

Follow-on Maintenance Action Required:

1. Close air system drain valves. Refer to para 13-20.
2. Put on dummy coupling. Refer to TM 9-2320-209-10.

END OF TASK

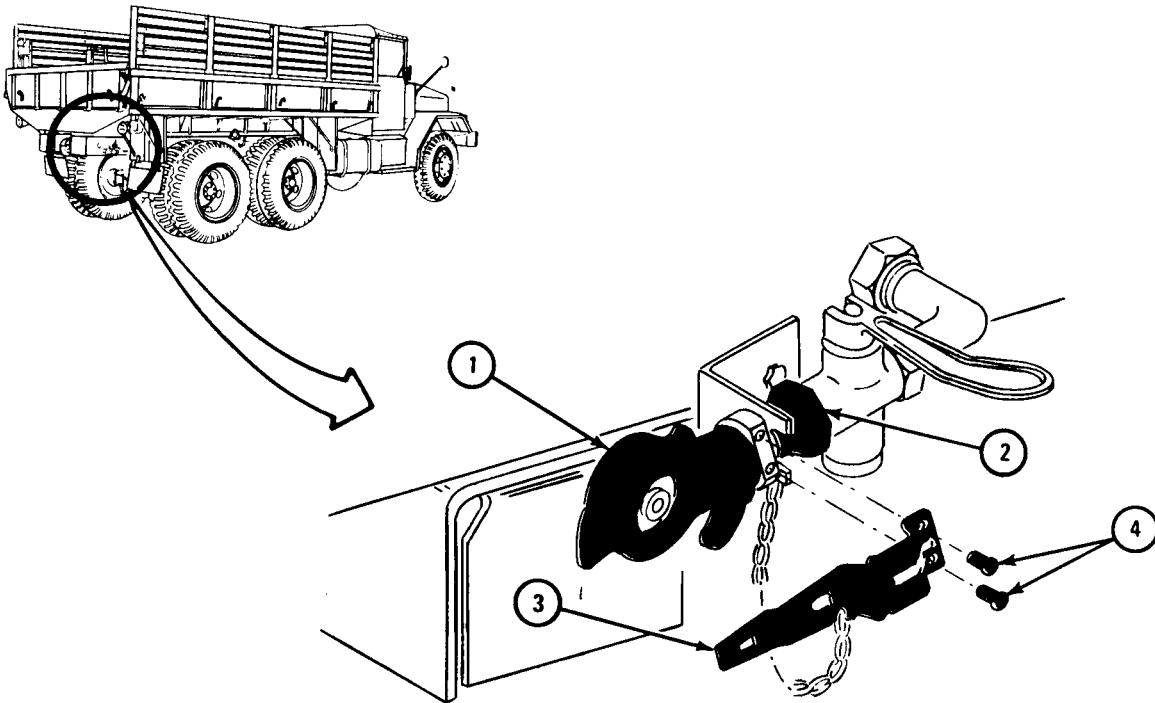

TA 101533

13-38. QUICK-DISCONNECT COUPLING HALF REPAIR.

NOTE

Repair of quick-disconnect coupling half is limited to replacement of seal. It is not necessary to remove quick-disconnect coupling half from truck or hose to replace seal.

TOOLS: Flat-tip screwdriver

SUPPLIES: Seal

PERSONNEL: One

EQUIPMENT CONDITION: Truck parked, engine off, handbrake set.

FRAME 1

WARNING

Be careful when taking out seal (1), not to cut hands with screwdriver.

1. Using screwdriver, pry seal (1) on outer edge of coupling half (2). Be careful not to break seal. If seal breaks, make sure to get all of the pieces out.
2. Throw away damaged seal (1).
3. Put new seal (1) into place.

END OF TASK

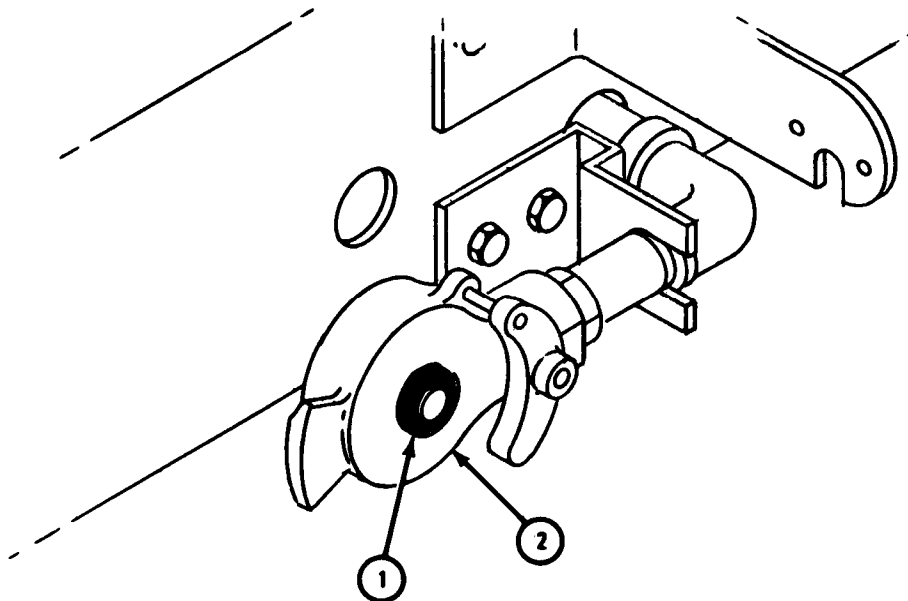

TA 046222

13-39. AIR BRAKE CUTOFF COCKS AND COUPLINGS REMOVAL AND REPLACEMENT
(ALL TRUCKS EXCEPT M764).

TOOLS: 9/16-inch wrench
1 1/4-inch wrench (2)
5/8-inch wrench
1 3/8-inch wrench
1 1/8-inch wrench
10-inch pipe wrench
1 1/2-inch wrench

SUPPLIES: Anti-seize tape, MIL-T-27730A

PERSONNEL: One

EQUIPMENT CONDITION: Truck parked, engine off, handbrake set.

a. Preliminary Procedures.

- (1) Vent air system. Refer to para 13-20.
- (2) Remove quick-disconnect coupling half. Refer to para 13-37.

b. Removal.

FRAME 1

1. Working on inside of frame and using 5/8-inch wrench, unscrew tube nut (1). Take off tube (2).
2. Using 9/16-inch wrench, unscrew and take off elbow (3).
3. Using 1 1/4-inch wrench, reach around to outside of frame and hold nut on nipple (4). Using 1 1/2-inch wrench, unscrew and take off nut (5).

GO TO FRAME 2

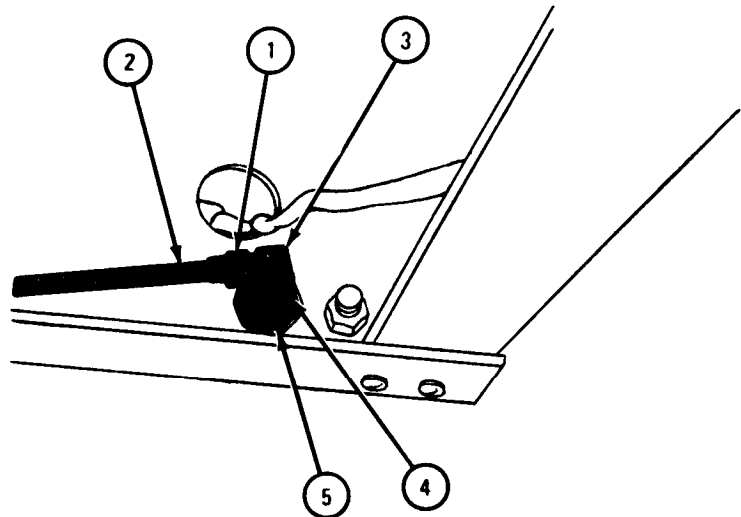
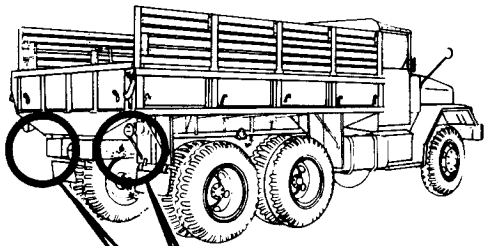

TA 089402

FRAME 2

NOTE

Some trucks will have bracket (1) and male elbow (2).
Other trucks will not have bracket and will have female elbow.

Note position of elbow (2) so that it is put back the same way.

1. Pull out valve assembly (3).
2. Using 1 3/8-inch wrench, hold valve (3). Using pipe wrench, unscrew and take out elbow (2).
3. Using 1 3/8-inch wrench, hold valve (3). Using 1 1/4-inch wrench, unscrew and take off nipple (4).

END OF TASK

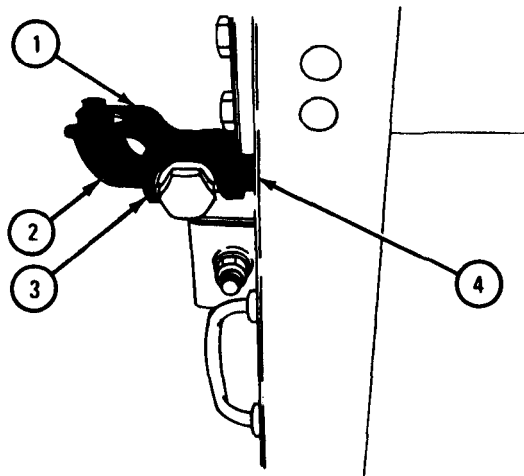

TA 089401

c. Replacement.

FRAME 1

NOTE

Some trucks will have bracket (1) and male elbow (2).
Other trucks will not have bracket and will have female
elbow.

1. Using 1 1/4-inch wrench, hold nipple (3). Using 1 3/8-inch wrench, screw on and tighten valve (4).
2. Using 1 3/8-inch wrench, hold valve (4). Using pipe wrench, screw on and tighten elbow (2) as noted.
3. Put valve assembly (4) in place as shown.

GO TO FRAME 2

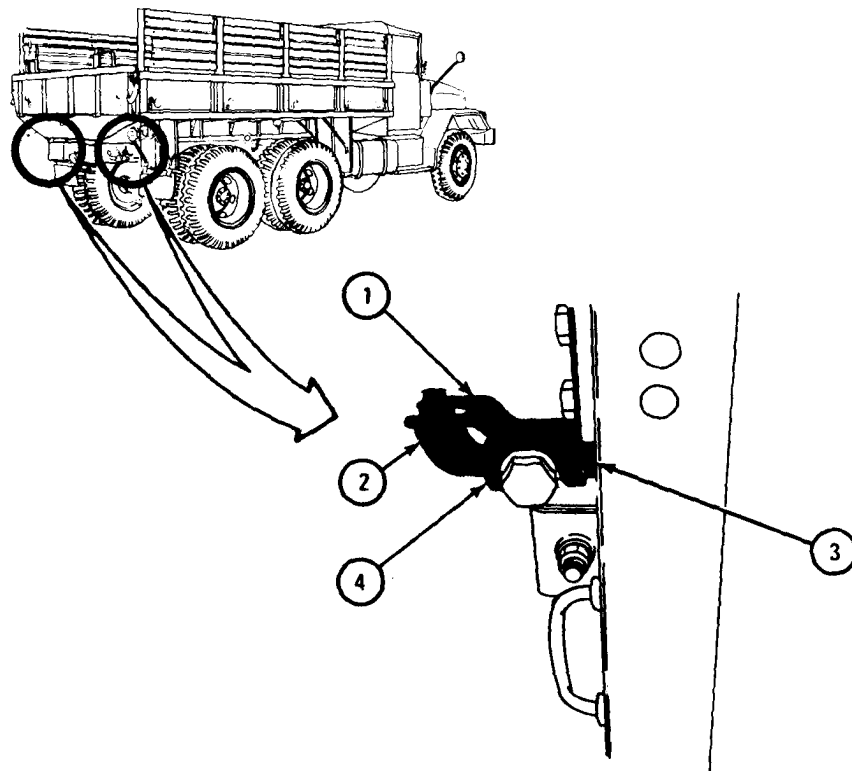

TA 089404

FRAME 2

1. Working from inside of frame and using 1 1/4-inch wrench, reach around to outside of frame and hold nut on nipple (1). Using 1 1/2-inch wrench, screw on and tighten nut (2) on nipple (1) as shown.
2. Using 1 1/4-inch wrench, hold nut (2). Using 9/16-inch wrench, screw on and tighten elbow (3).
3. Put tube (4) in place as shown. Using 5/8-inch wrench, screw on and tighten tube nut (5).

NOTE

Follow-on Maintenance Action Required:

1. Replace quick-disconnect coupling half. Refer to para 13-37.
2. Do air leak test. Refer to Part 1, para 1-5.

END OF TASK

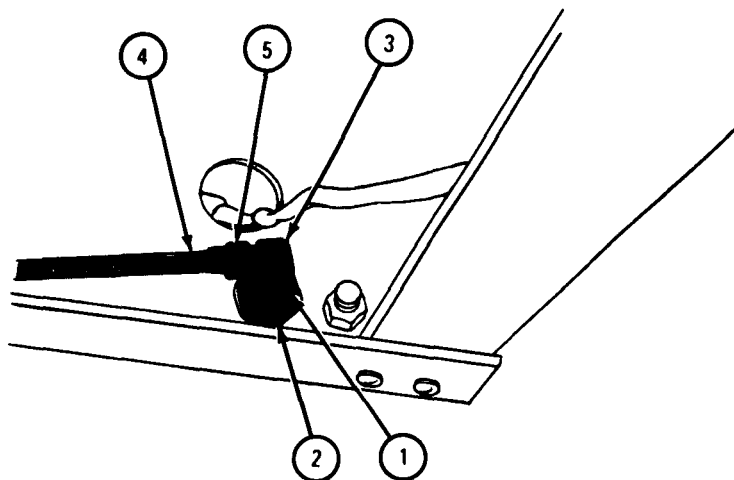

TA 089403

13-40. AIR BRAKE CUTOFF COCKS AND COUPLINGS REMOVAL AND REPLACEMENT
(TRUCK M764).

TOOLS: 1 3/8-inch wrench
3/4-inch wrench
5/8-inch wrench
1 1/4-inch wrench
10-inch pipe wrench
9/16-inch wrench (2)
1 1/2-inch wrench
Vise

SUPPLIES: None

PERSONNEL: One

EQUIPMENT CONDITION: Truck parked, engine off, handbrake set.

a. Preliminary Procedures.

(1) Vent air system pressure. Refer to para 13-20.

(2) Remove quick-disconnect coupling half. Refer to para 13-37.

b. Removal.

FRAME 1

1. Using 5/8-inch wrench, unscrew and take off tube nut (1). Take off tube (2).
2. Using 1 3/8-inch wrench, hold valve (3). Using 3/4-inch wrench, unscrew and take off elbow (4).
3. Using 9/16-inch wrenches, unscrew and take off two screws (5) and two nuts (6). Take off bracket (7).
4. Using 10-inch pipe wrench, unscrew and take off elbow (8).
5. Using 1 1/4-inch wrench, hold nut on nipple (9). Using 1 1/2-inch wrench, unscrew and take off nut with washer (10). Take off valve (3) with nipple.
6. Put valve (3) in vise. Using 1 1/4-inch wrench, unscrew and take off nipple (9).

END OF TASK

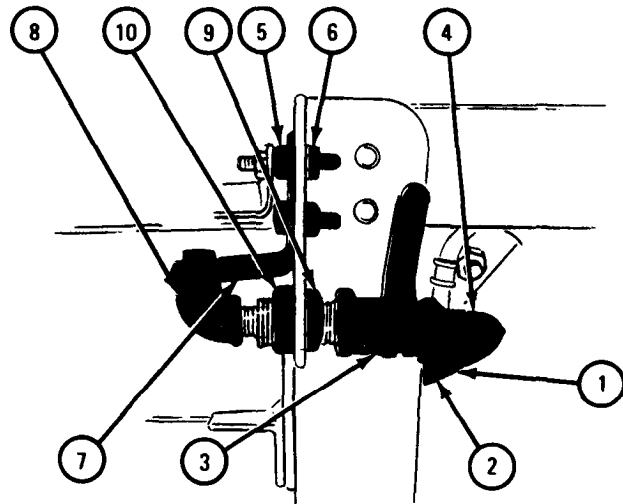
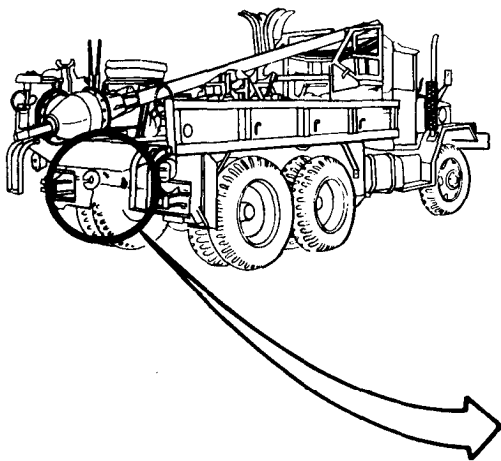

TA 089405

c. Replacement.

FRAME 1

1. Put valve (1) in vise. Using 1 1/4-inch wrench, screw in and tighten nipple (2). Put valve with nipple in place as shown.
2. Using 1 1/4-inch wrench, hold nut on nipple (2). Using 1 1/2-inch wrench, screw on and tighten nut with washer (3).
3. Using 1 1/4-inch wrench, hold nut (3). Using 10-inch pipe wrench, screw on and tighten elbow (4).
4. Using 3/4-inch wrench, screw on elbow (5).
5. Put tube (6) in place. Using 5/8-inch wrench, screw on and tighten tube nut (7).
6. Put bracket (8) in place. Using 9/16-inch wrenches, screw in and tighten two screws (9) and two nuts (10).

NOTE

Follow-on Maintenance Action Required:

1. Replace quick-disconnect coupling half. Refer to para 13-37.
2. Do air system leak test. Refer to Part 1, para 1-5

END OF TASK

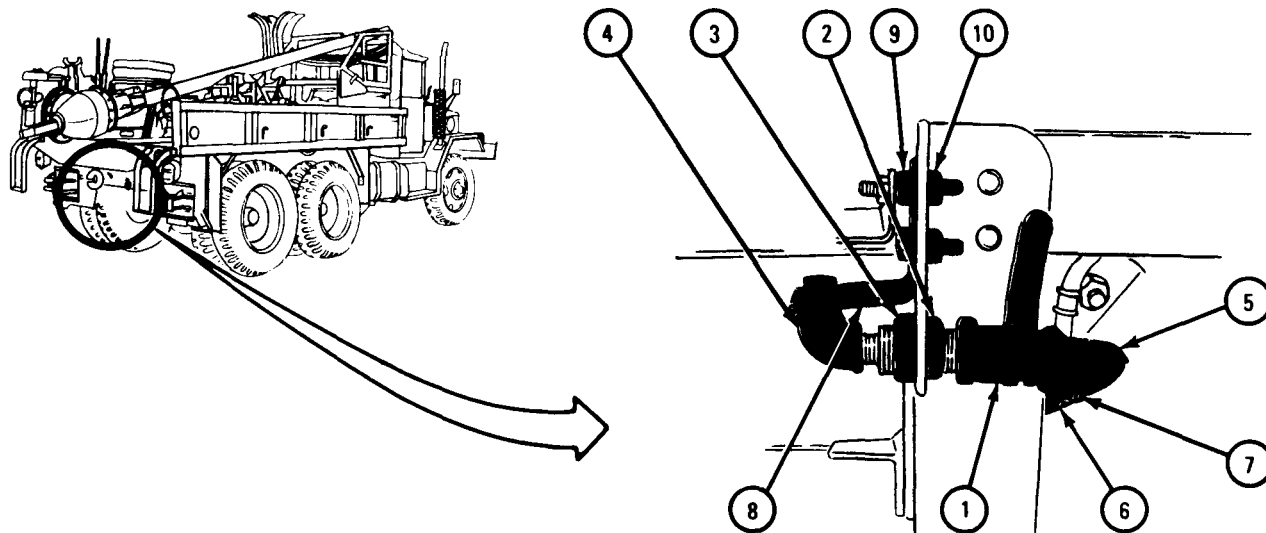

TA 089406

13-41. AIR BRAKE HOSE REMOVAL AND REPLACEMENT.

TOOLS: 1-inch wrench
1 1/16-inch wrench
12-inch adjustable wrench
15-inch adjustable wrench

SUPPLIES: None

PERSONNEL: One

EQUIPMENT CONDITION: Truck parked, engine off, handbrake set.

- a. Preliminary Procedure. Vent air system pressure. Refer to para 13-20.
- b. Removal.

FRAME 1

1. Turn valve handle (1) to the on (down) position.
2. Using adjustable wrench, hold valve (2). Using 1-inch wrench, unscrew coupling nut (3). Take off coupling nut and hose (4).

GO TO FRAME 2

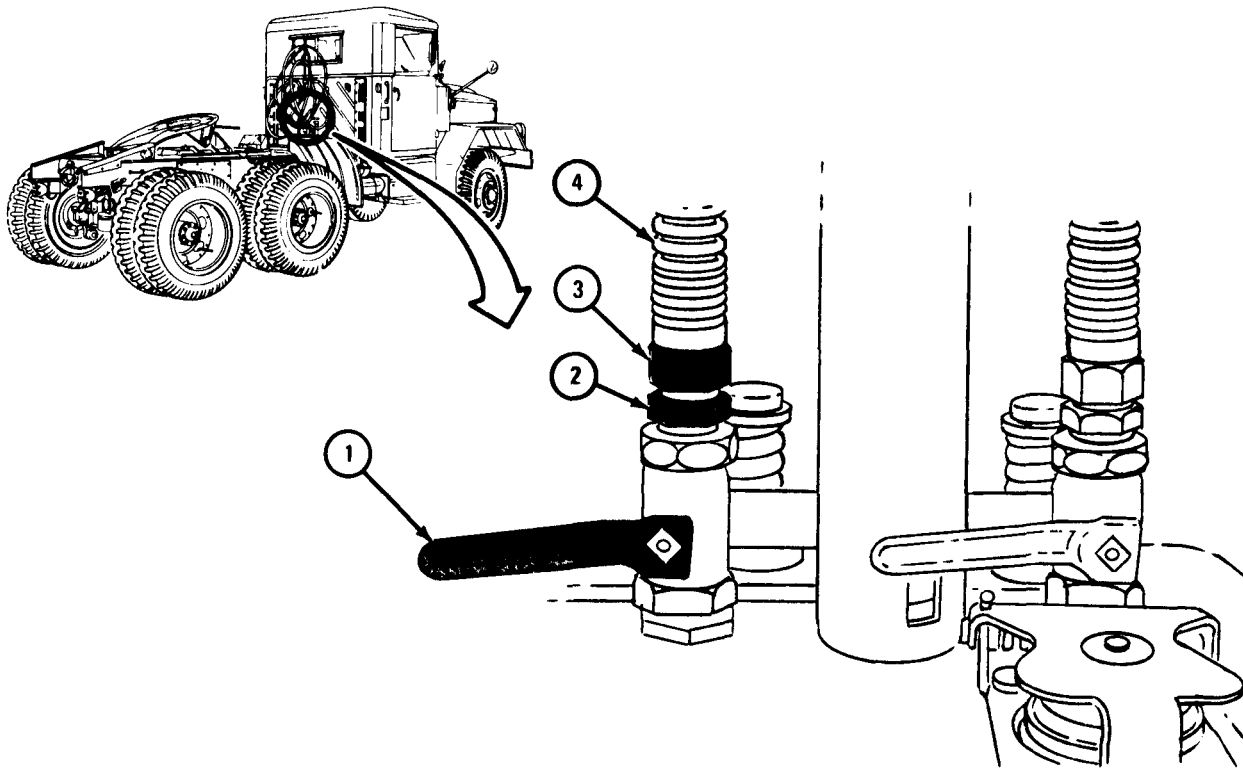

TA 046366

FRAME 2

1. Start hose (1) and nut (2) into valve (3), and using 1-inch wrench, tighten nut (2).
2. Turn valve handle (4) to the off (up) position.

GO TO FRAME 3

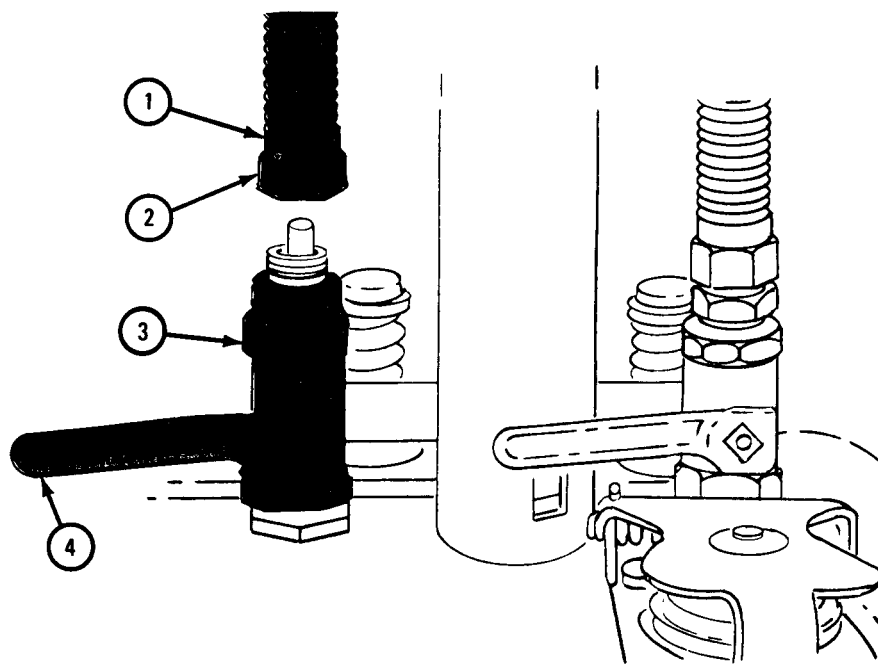

TA 046371

FRAME 3

1. Find end of hose that has quick-disconnect coupling (1) on it.
2. Using adjustable wrench (2), hold quick-disconnect coupling (1). Using 1-inch wrench, unscrew and take off coupling (3).

END OF TASK

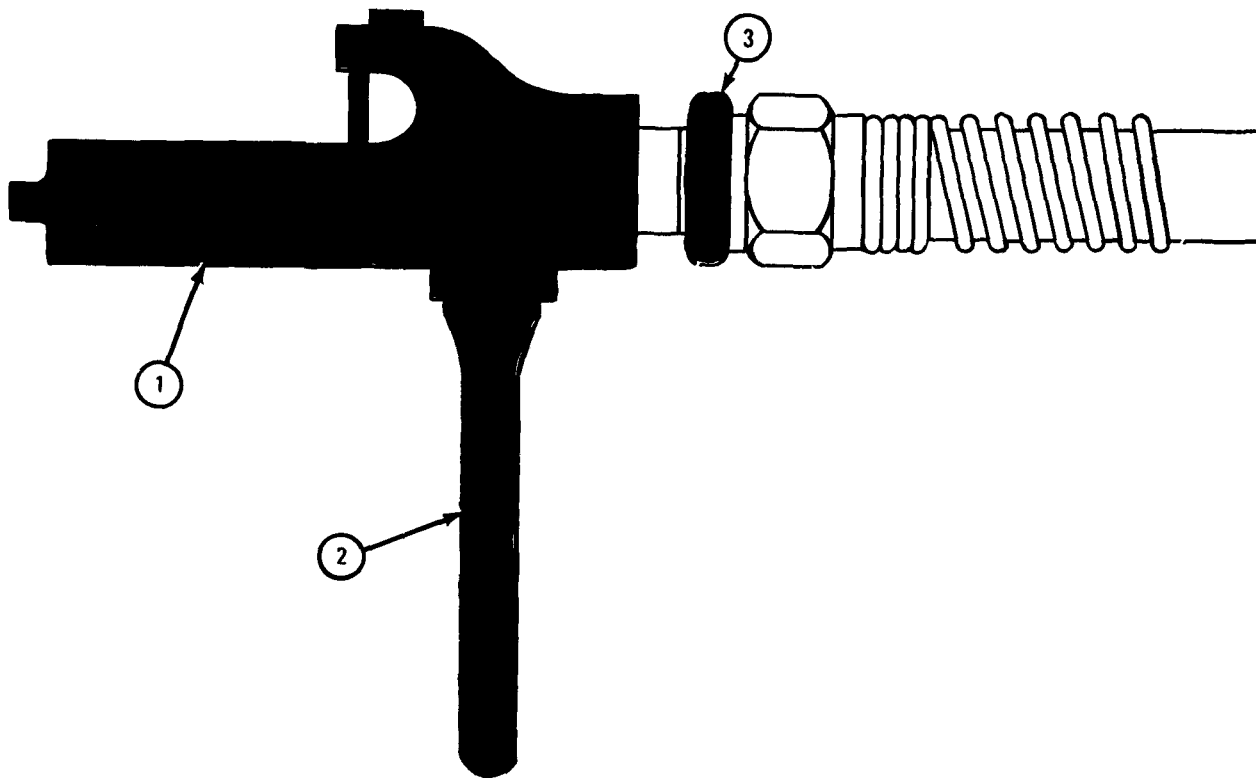

TA 046372

c. Replacement.**FRAME 1**

1. Using adjustable wrench (1), hold quick-disconnect coupling (2). Using 1-inch wrench, screw in coupling nut (3) and hose nut (4).

GO TO FRAME 2

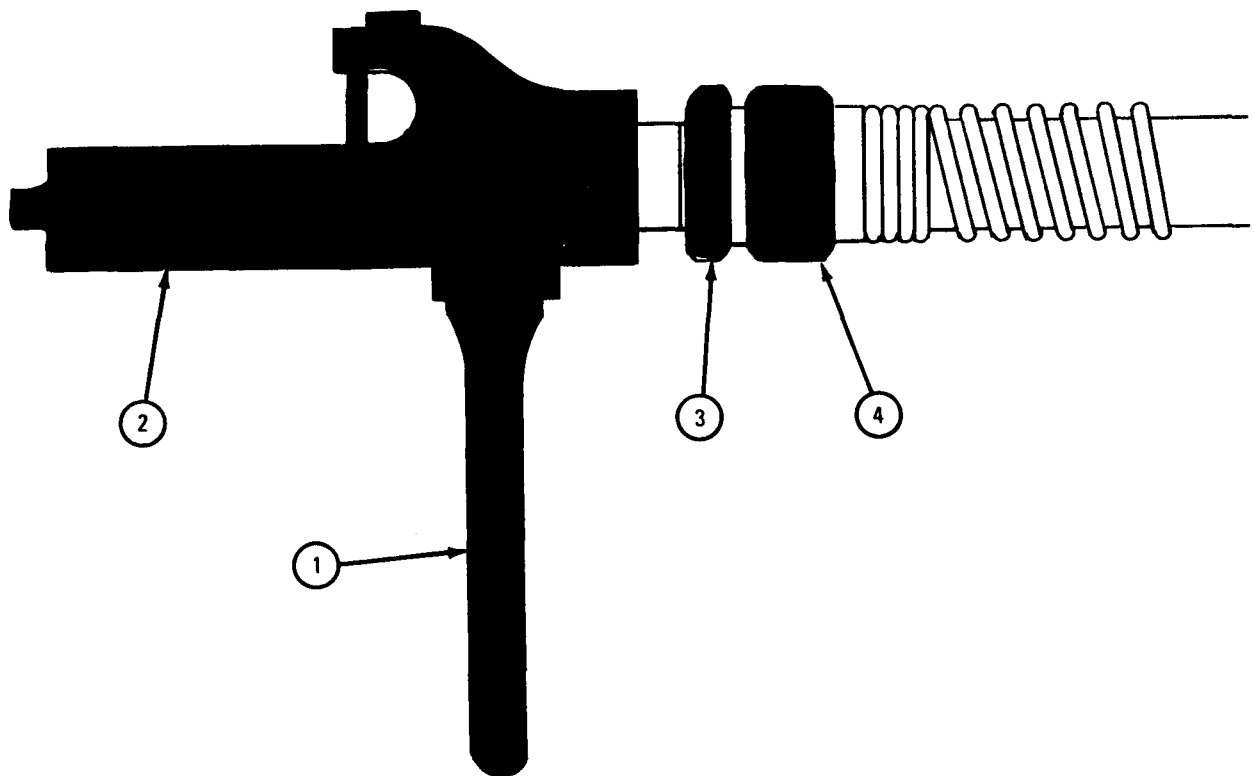

TA 046373

FRAME 2

1. Using adjustable wrench, hold valve (1). Using 1 1/16-inch wrench, screw in coupling (2).

2. Turn valve handle (3) to the off (up) position.

END OF TASK

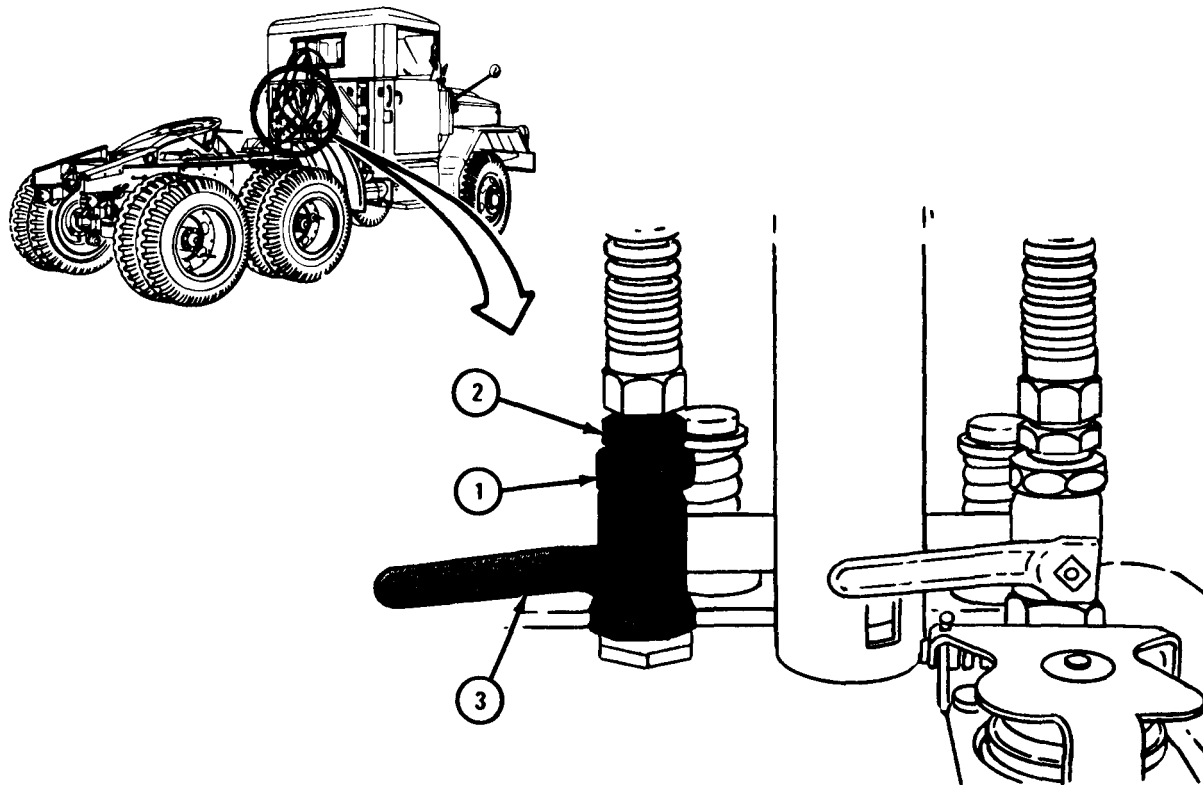

TA 046374

13-42. AIR BRAKE HOSE REPAIR.

TOOLS: 1 1/16-inch wrench
1-inch wrench
Hacksaw
6-inch steel ruler

SUPPLIES: Compressed air source, 30 psi max

PERSONNEL: One

EQUIPMENT CONDITION: Truck parked, engine off, handbrake set.

a. Preliminary Procedure. Remove air brake hose from truck. Refer to para 13-41.

b. Repair.

NOTE

Repair of air brake hose is limited to replacement of adapters and pipe to hose.

FRAME 1

1. Slide coupling nut (1) with spring (2) back on hose (3) so sleeve (4) is uncovered.
2. Using hacksaw, saw off end of hose (3) just behind sleeve (4). Throw away sleeve with piece of hose.
3. Take coupling nut (1) with spring (2) off of hose (3) and throw away nut and spring.

GO TO FRAME 2

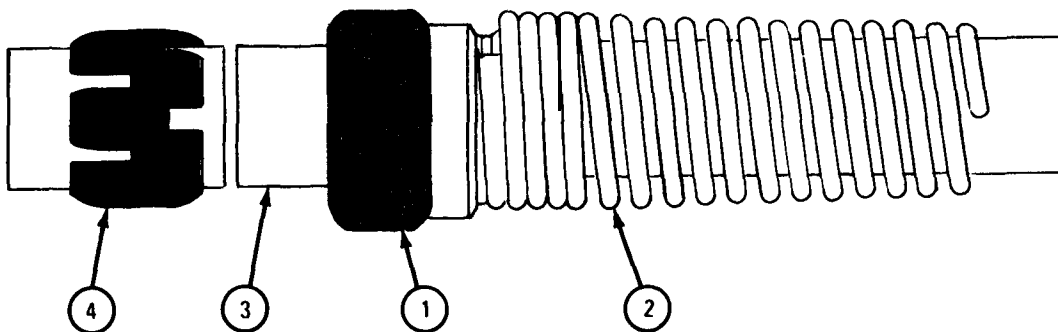

TA 046375

FRAME 2

1. Screw spring (1) onto couplkng nut (2). Put spring and coupling nut onto hose (3) with coupling nut to end of hose being worked on.
2. Check sleeve (4). One end has longer slots on outside. Find the end with longer slots.
3. Hold sleeve (4) so that end with longer slots is to end of hose (3) being worked on.
4. Screw sleeve (4) onto hose (3) so hose is 5/16 inch up from end of hose. Measure with ruler.

GO TO FRAME 3

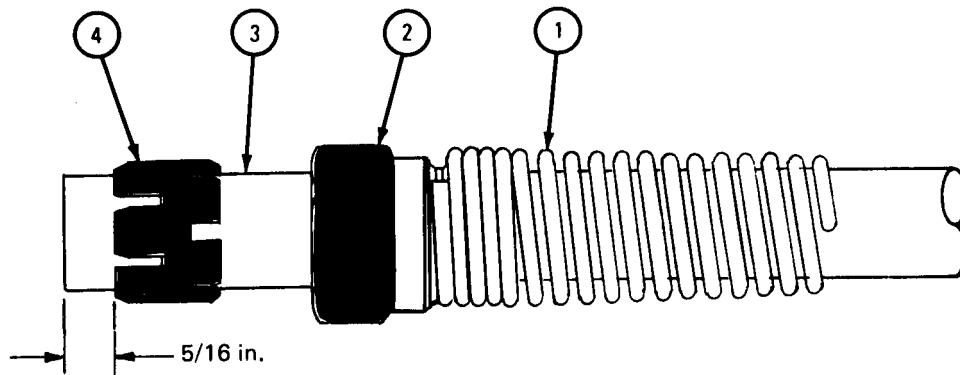

TA 046376

FRAME 3

1. Put hose (1) onto adapter (2). Make sure that hose goes all the way into adapter.
2. Push coupling nut (3) with spring (4) down to adapter (2). Make sure hose (1) has not worked back out of adapter.
3. Using 1-inch wrench, hold adapter (2). Using 1 1/16-inch wrench, screw on coupling nut (3).

GO TO FRAME 4

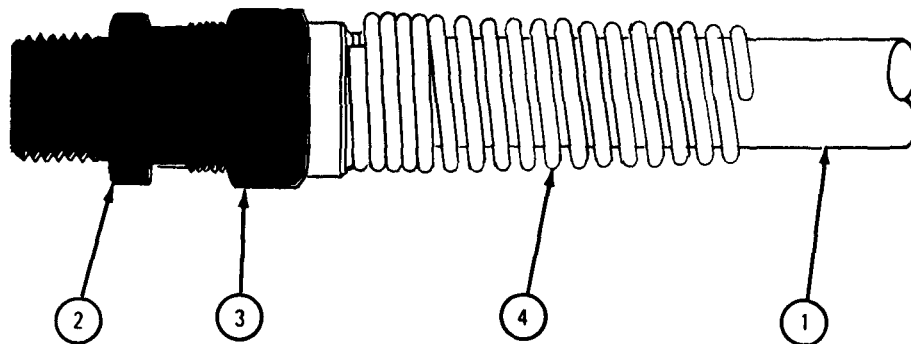

TA 046377

FRAME 4

1. Using 1-inch wrench, hold adapter (1). Using 1 1/16-inch wrench, screw coupling nut (2). Take away and save adapter.
2. Slide coupling nut (2) with spring (3) back on hose (4) so sleeve (5) can be seen. Sleeve must be tight on hose and hose must be out past sleeve.
3. Go to other end of hose and do frames 1, 2, and 3 again. Do steps 1 and 2 of this frame again. Then go to step 4.

WARNING

Eye shields must be worn when using compressed air.
Eye injury can occur if eye shields are not used.

4. Using compressed air, blow through hose (4) to clean out any chips or dirt.

NOTE

Follow-on Maintenance Action Required:

Replace adapter and hose in truck. Refer to para 13-41.

END OF TASK

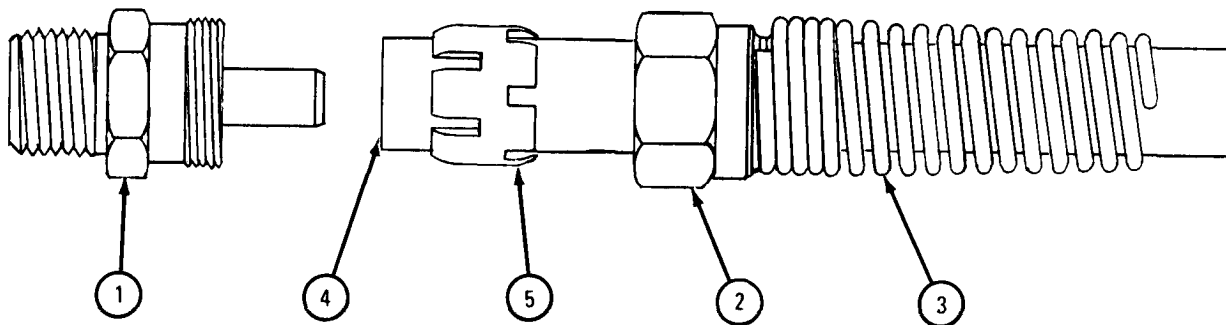

TA 046378

CHAPTER 14

WHEEL SYSTEM GROUP MAINTENANCE

Section I. SCOPE

14-1. EQUIPMENT ITEMS COVERED. This chapter gives equipment maintenance for the front wheel assembly, rear wheel assembly, and tires for which there are authorized corrective maintenance tasks at the organizational maintenance level.

14-2. EQUIPMENT ITEMS NOT COVERED. All equipment items for which corrective maintenance is authorized at the organizational maintenance level are covered in this chapter.

Section II. FRONT WHEEL ASSEMBLY

14-3. FRONT WHEEL AND BRAKE DRUM ASSEMBLY REMOVAL AND REPLACEMENT.

TOOLS: Wheel bearing nut wrench, Torque wrench, 150 pound-feet
 pn 7076869 capacity
 3/4-inch wrench Portable bearing lubricator
 3/4-inch socket wrench Wheel lift truck
 Hand grease gun

SUPPLIES: Drive flange gasket
 Artillery and automotive grease, type GAA, MIL-G-10924

PERSONNEL: One

EQUIPMENT CONDITION: Truck parked on level ground, engine off, handbrake set.

a. Preliminary Procedure. Jack up and support front axle housing. Refer to Part 1, para 11-3.

b. Removal.

FRAME 1

1. Using 3/4-inch wrench, unscrew and take off eight capscrews and eight lockwashers (1), flange (2), and gasket (3). Throw away gasket.

GO TO FRAME 2

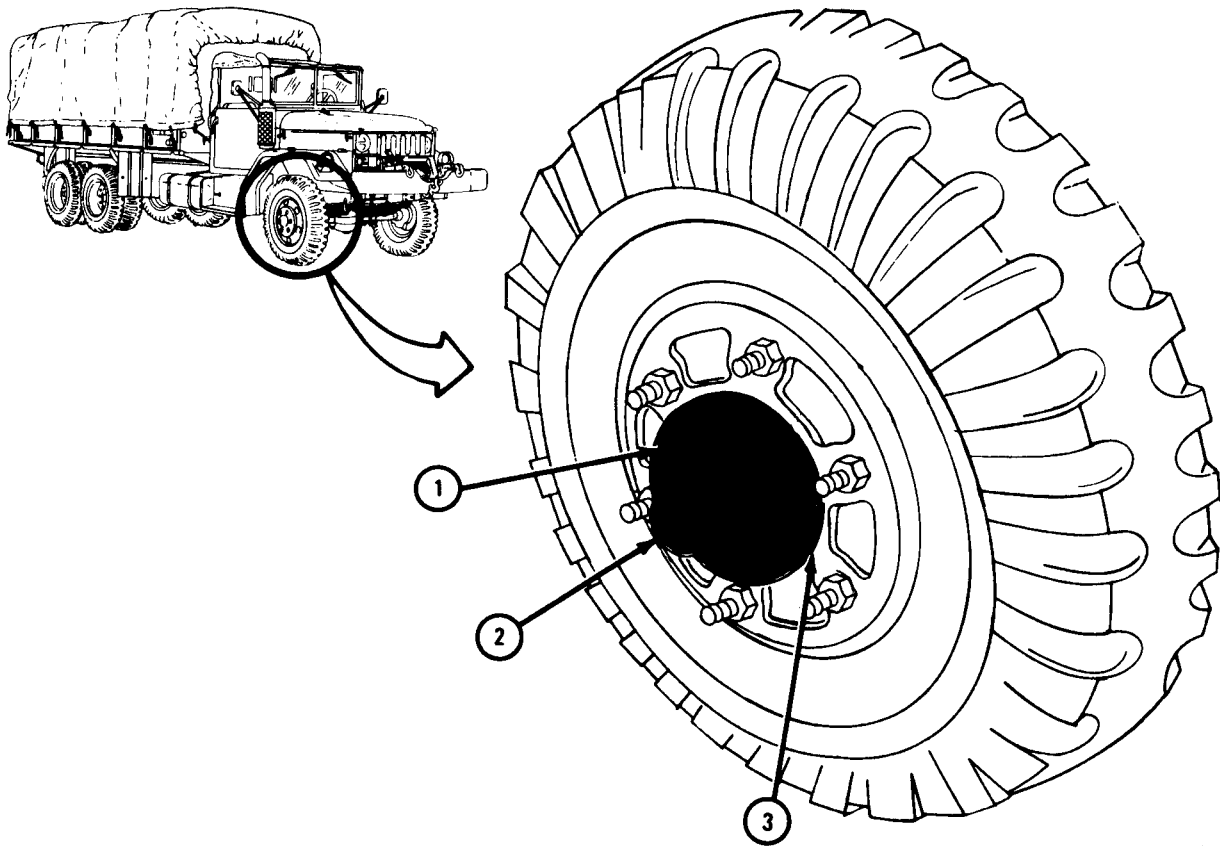

TA 080999

FRAME 2

1. Using hammer and punch, bend up tabs on adjusting nut lockwasher (1) so locknut (2) can be turned.
2. Using wheel bearing nut wrench and socket handle, unscrew and take off locknut (2). Take off adjusting nut lockwasher (1).

GO TO FRAME 3

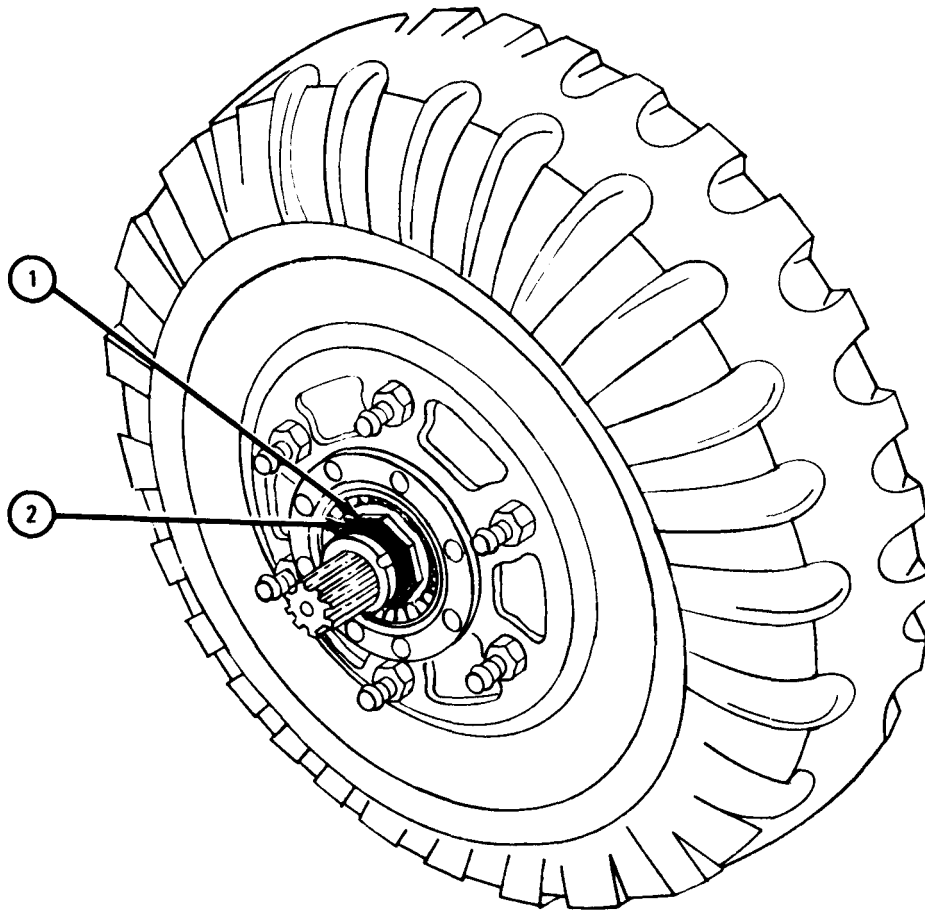

TA 083241

FRAME 3

1. Using wheel bearing nut wrench and socket handle, unscrew and takeoff adjusting nut (1).

GO TO FRAME 4

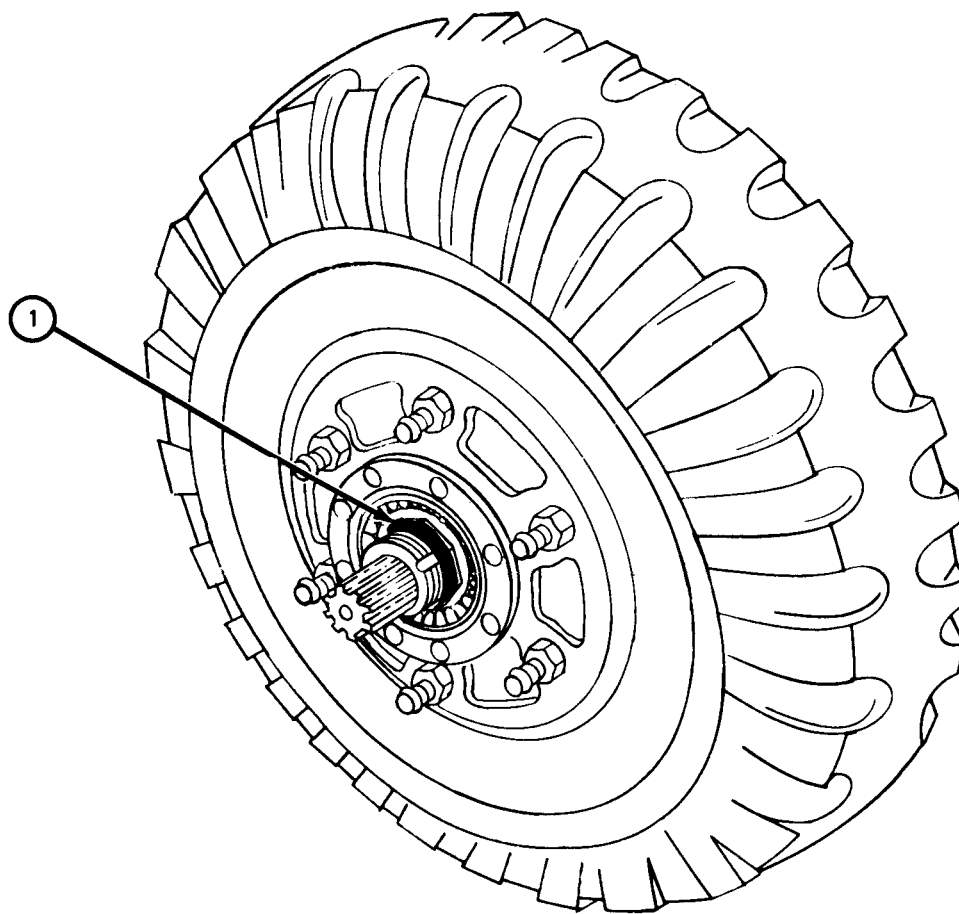

TA 083242

FRAME 4

1. Put wheel lift truck under front tire (1) as shown.
2. Jack up wheel lift truck until lift arms just touch tire (1).
3. Shake top of tire (1) until outer wheel bearing cone (2), moves out of hub (3). Take off outer wheel bearing cone.
4. Level lift arms on wheel lift truck until wheel and drum assembly (4) can be pulled straight off spindle (5).
5. Pull wheel lift truck and wheel and drum assembly (4) away from truck.

END OF TASK

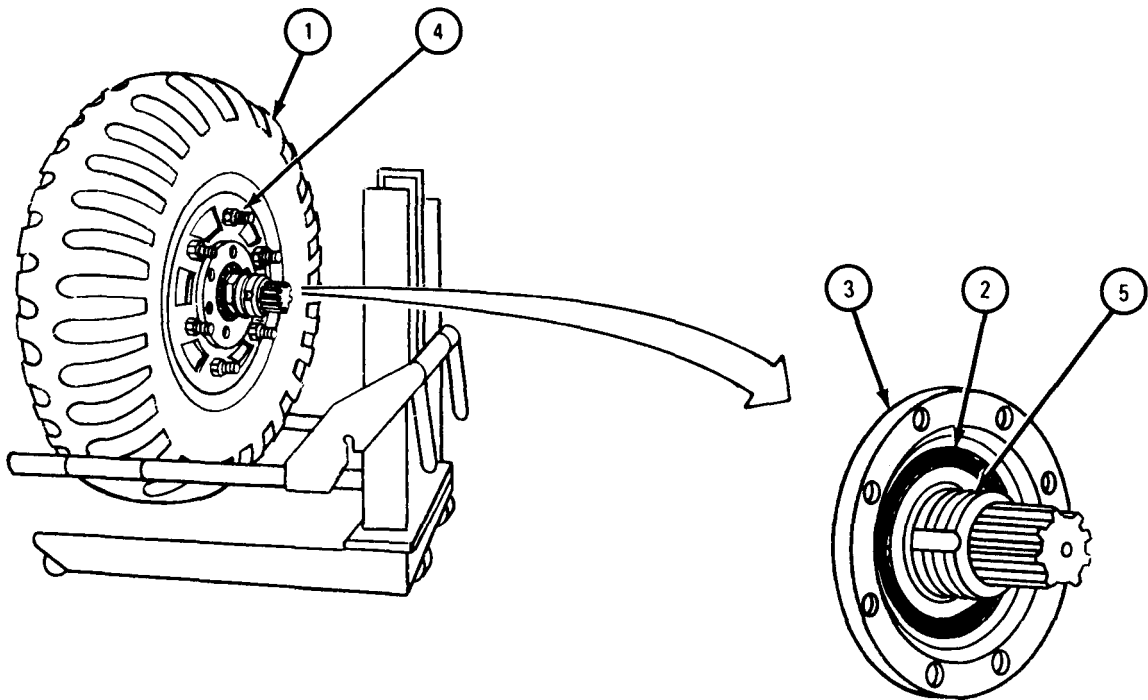

TA 083243

c. Replacement.

CAUTION

Do not let lip of seal drag over threaded end of spindle. Seal can be damaged.

FRAME 1

1. Push wheel lift truck and wheel and drum assembly (1) toward truck so hub (2) goes on spindle (3) as shown.

GO TO FRAME 2

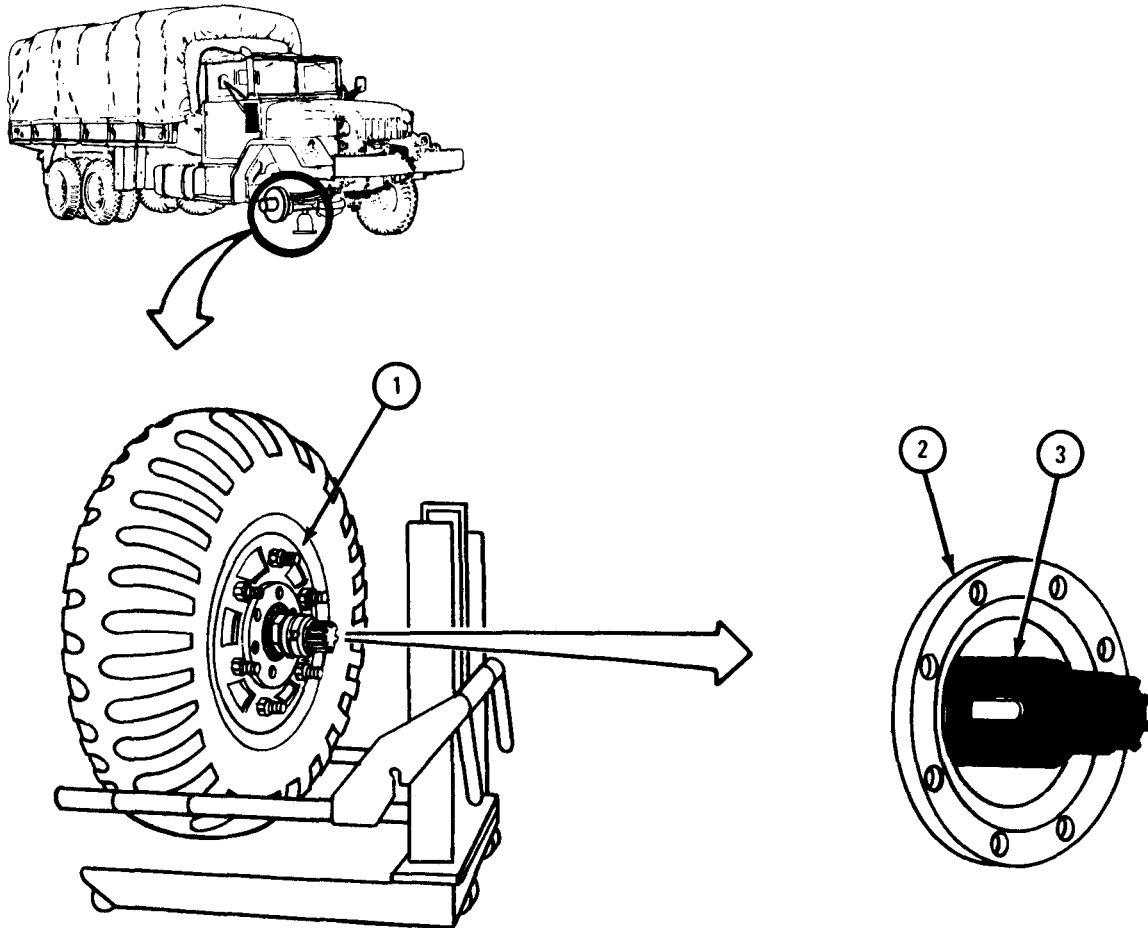

TA 083244

FRAME 2

1. Using portable bearing lubricator and hand grease gun, grease outer wheel bearing cone (1).
2. Put outer wheel bearing cone (1) in hub (2) as shown.
3. Using wheel bearing nut wrench and socket handle, screw on adjusting nut (3).
4. Lower wheel lift truck and take it away from truck.

GO TO FRAME 3

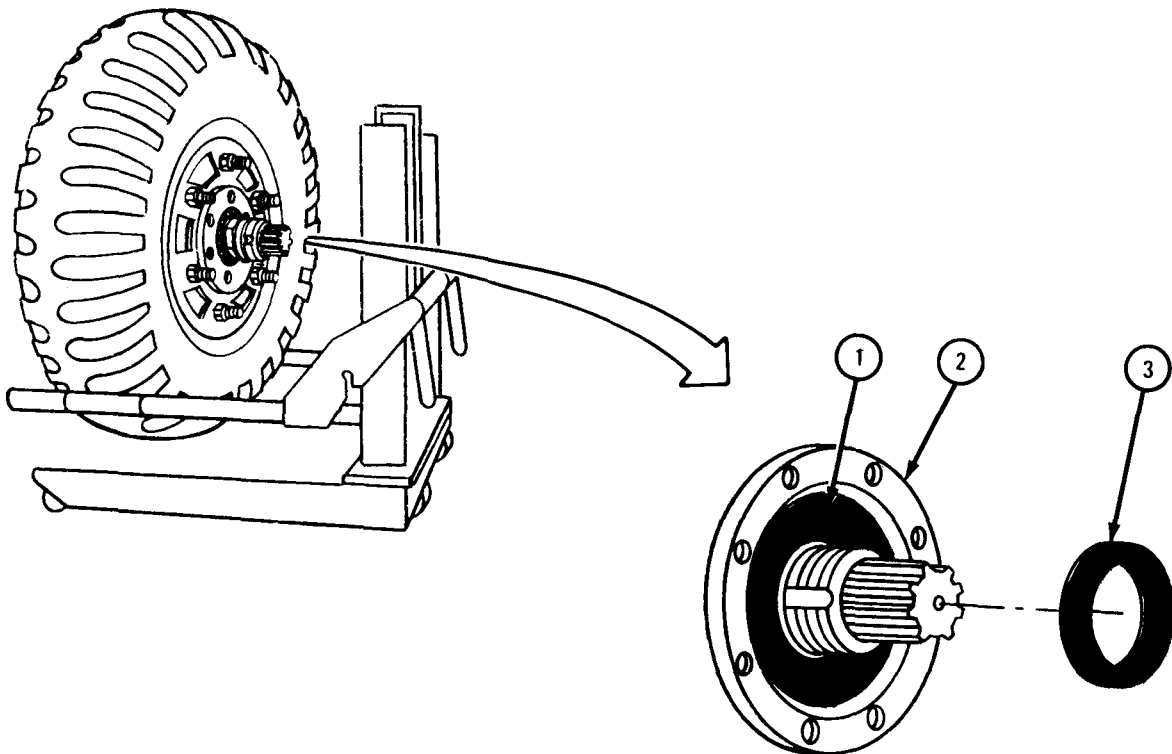

TA 083245

FRAME 3

1. Check brake adjustment. Refer to para 13-9.
2. While turning wheel (1), using wheel bearing nut wrench with socket handle, tighten adjusting nut (2) until wheel binds. Then back off adjusting nut $1/8$ turn.
3. Put one hand on bottom and one hand on top of wheel (1). Push with one hand and pull with the other hand. If wheel bearing cone (3) adjustment is correct, there will be very little wobble.

GO TO FRAME 4

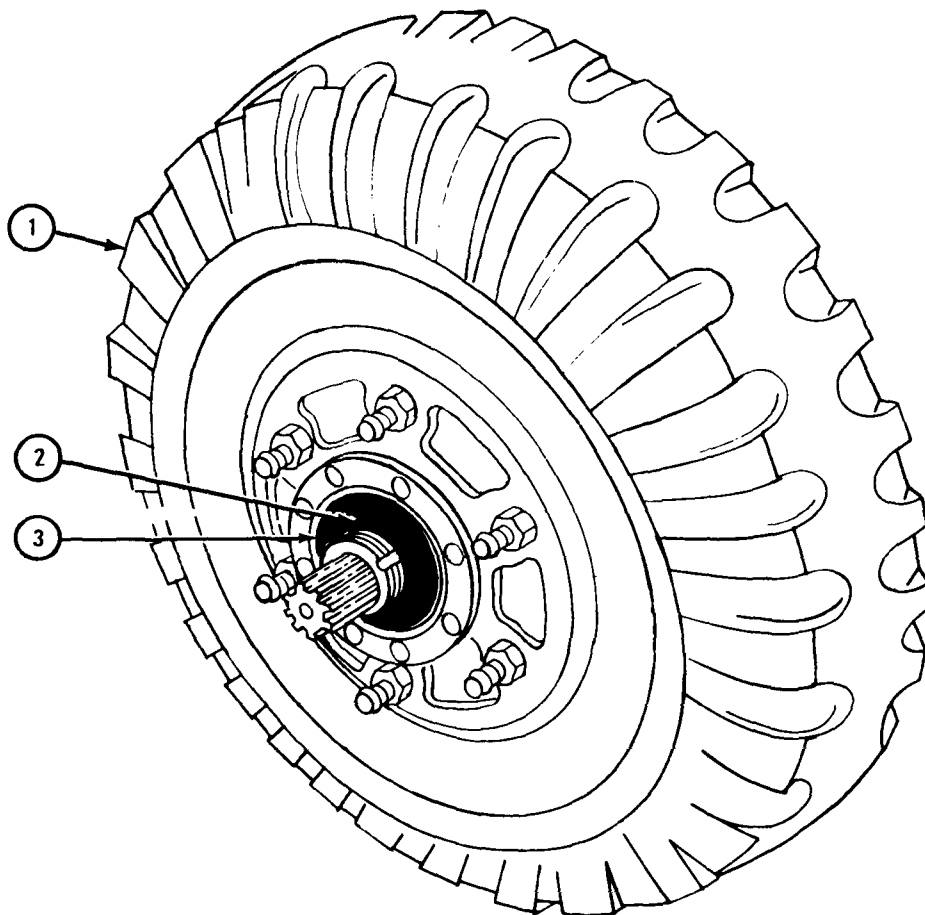

TA 101742

FRAME 4

1. Put on adjusting nut lockwasher (1).
2. Using wheel bearing nut wrench and socket handle, screw on locknut (2).
Using torque wrench, tighten locknut to 100 to 150 pound-feet.
3. Using hammer and punch, bend tabs of adjusting nut lockwasher (1) over both adjusting nut (3) and locknut (2).

GO TO FRAME 5

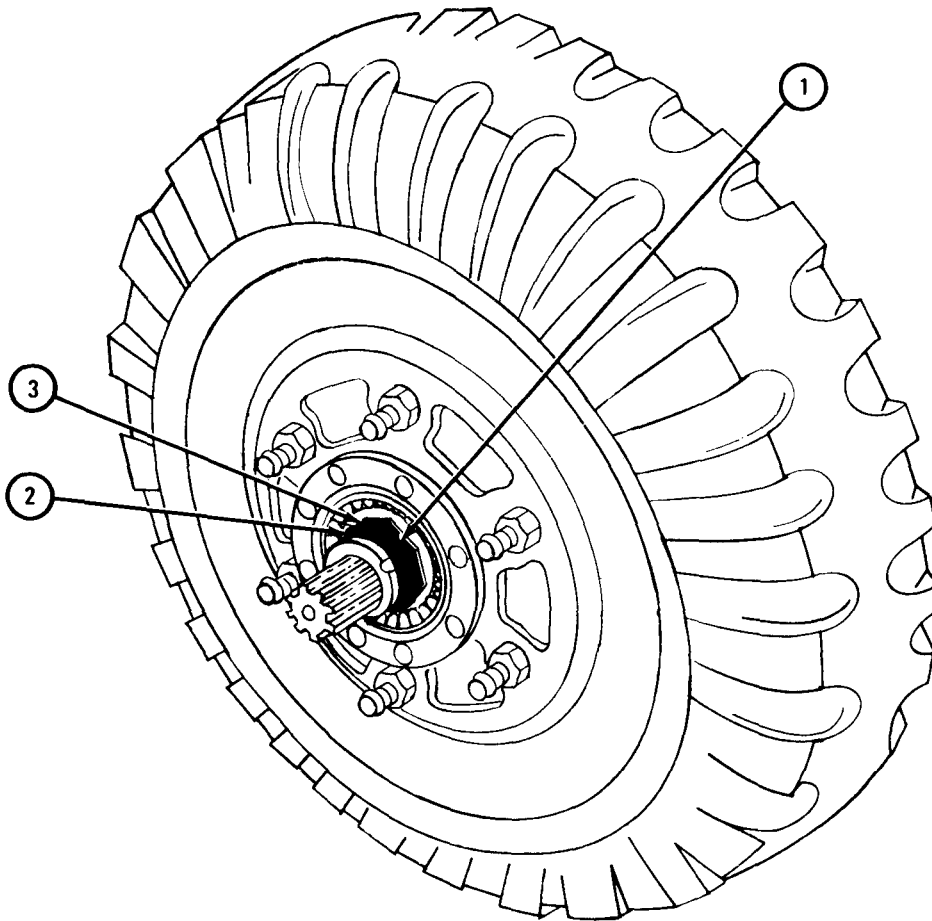

TA 047622

FRAME 5

1. Aline screw holes in flange (1), flange gasket (2), and hub (3).
2. Using 3/4-inch wrench, screw in eight capscrews and eight lockwashers (4).
3. Jack up front axle housing. Take out support stands. Lower wheels to ground and take away jack.
4. Using torque wrench and 3/4-inch socket wrench, tighten eight capscrews (4) evenly to 85 to 95 pound-feet.

END OF TASK

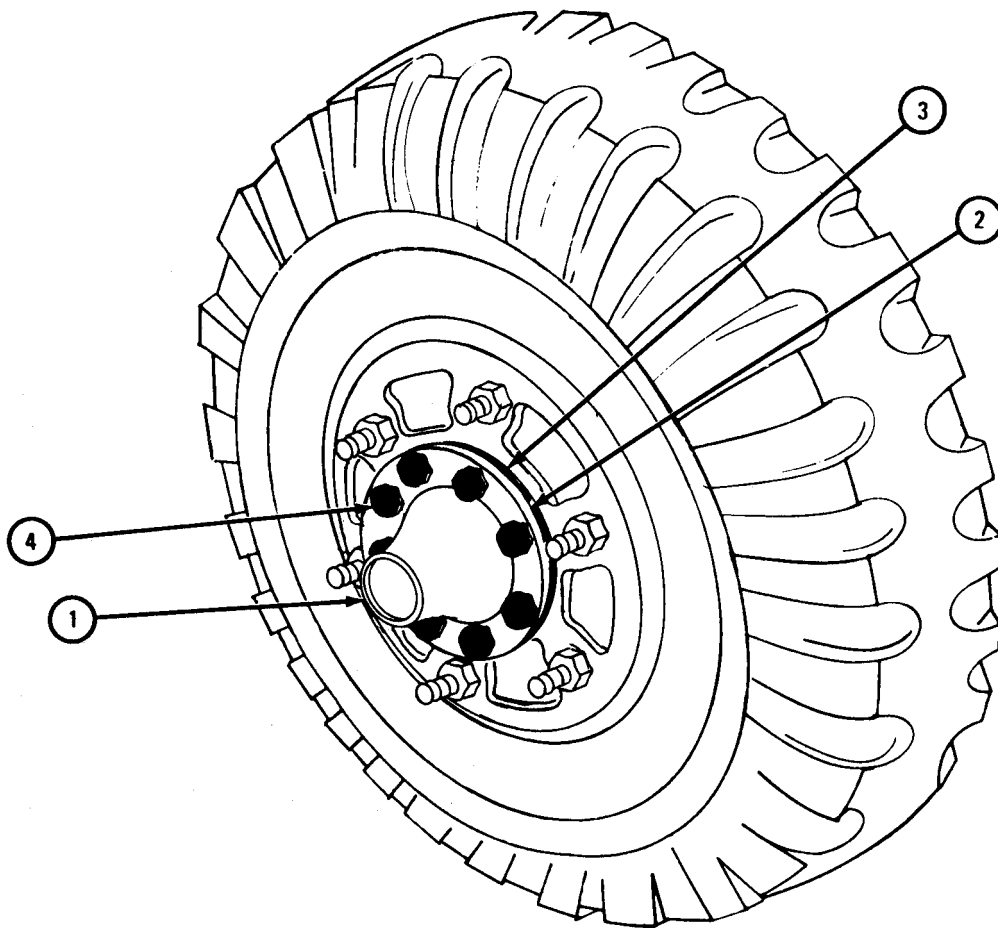

TA 101745

14-4. FRONT HUB AND BRAKE DRUM ASSEMBLY REMOVAL AND REPLACEMENT.

- TOOLS: 3/4-inch socket wrench
 8-ounce ballpeen hammer
 1/4-inch drive pin punch
 Portable bearing lubricator
 Grease gun
 3/4-inch wrench
 Wheel bearing nut wrench, pn 7076869
 Torque wrench, 150 pound-feet capacity
 10-inch socket handle

- SUPPLIES: Drive flange gasket
 Artillery and automotive grease, type GAA, MIL-G-10924

PERSONNEL: Two

EQUIPMENT CONDITION: Truck parked on level ground, engine off, handbrake set.

a. Preliminary Procedure. Jack up and remove front wheel. Refer to TM 9-2320-209-10.

b. Removal.

FRAME 1

1. Using 3/4-inch wrench, unscrew and take off eight capscrews and eight lock-washers (1), flange (2), and gasket (3). Throw away gasket.

GO TO FRAME 2

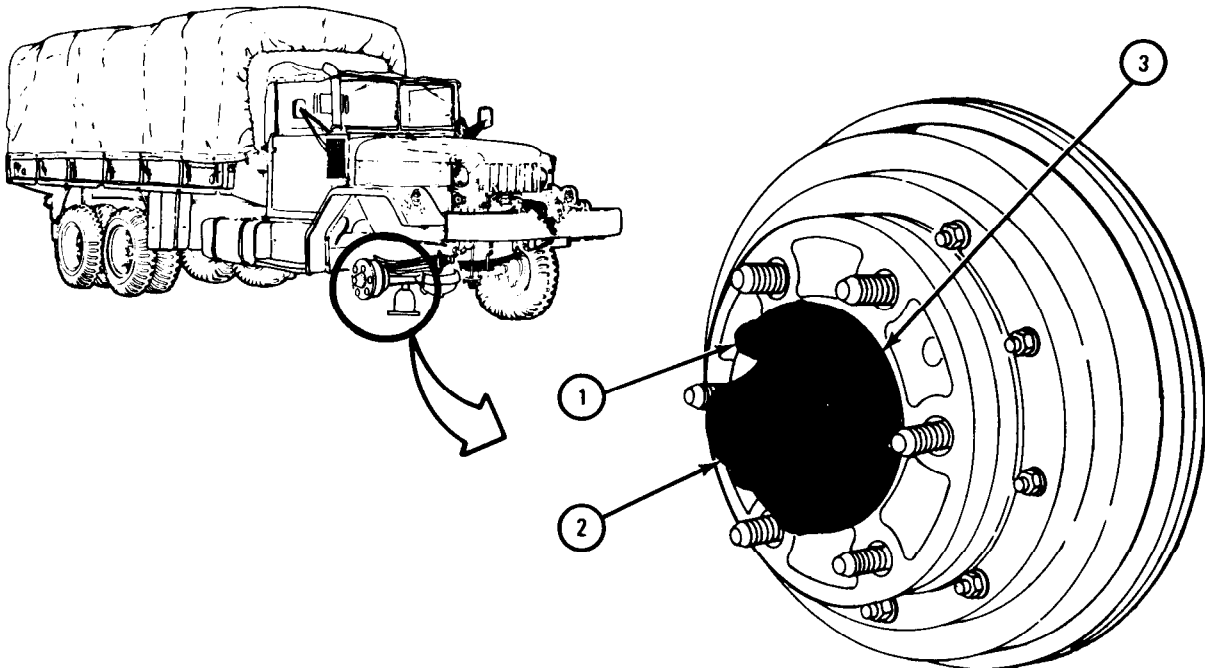

TA 047614

FRAME 2

1. Using hammer and punch, bend tabs on adjusting nut lockwasher (1) so locknut (2) can be turned.
2. Using wheel bearing nut wrench and socket handle, unscrew and take off locknut (2). Take off adjusting nut lockwasher (1).

GO TO FRAME 3

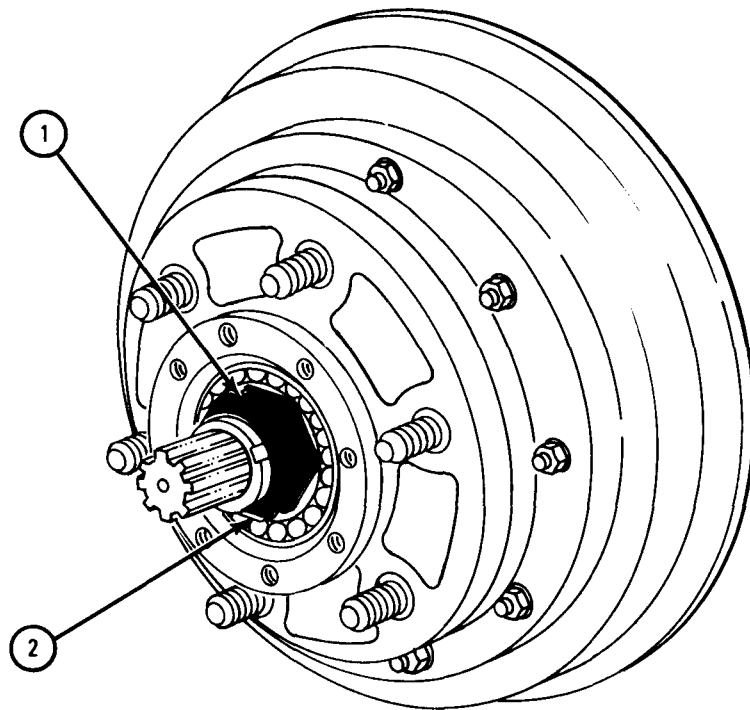

TA 047615

FRAME 3

1. Using wheel bearing nut wrench and socket handle, unscrew and take off adjusting nut (1).

GO TO FRAME 4

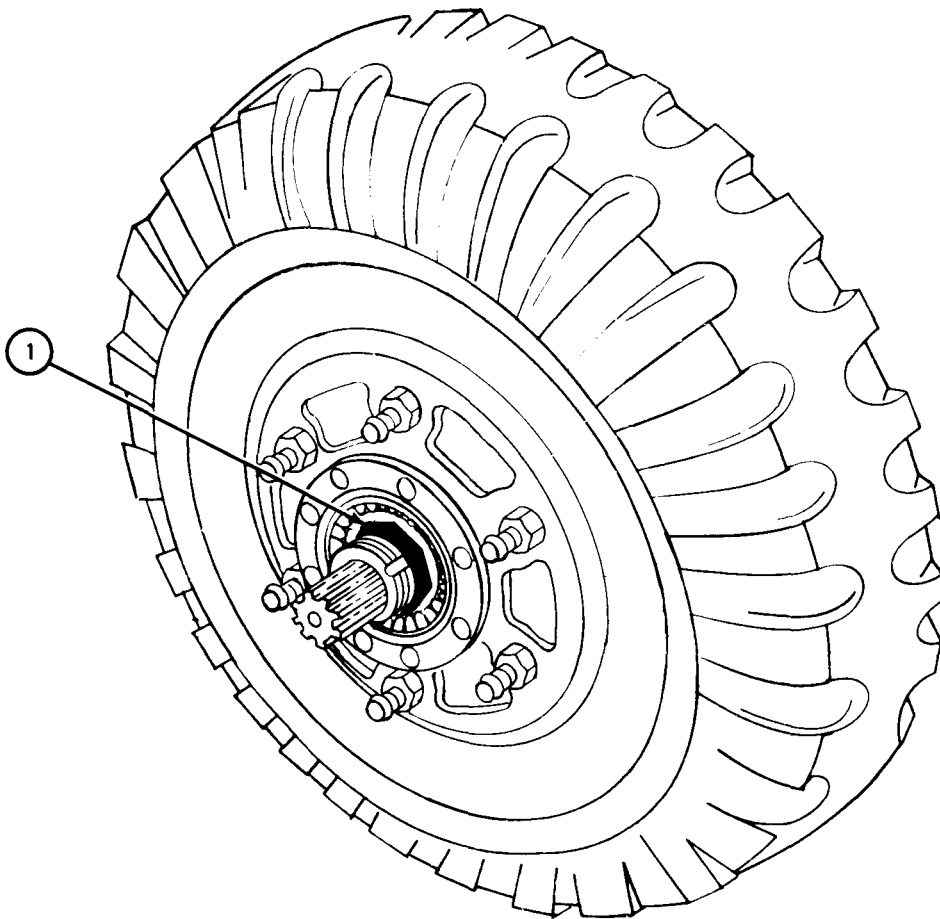

TA 047353

FRAME 4

1. Pull bearing cone (1) and hub and drum assembly (2) out about 1 inch. Push hub and drum assembly back and take off bearing cone.

Soldiers 2. Take off hub and drum assembly (2).

A and B

END OF TASK

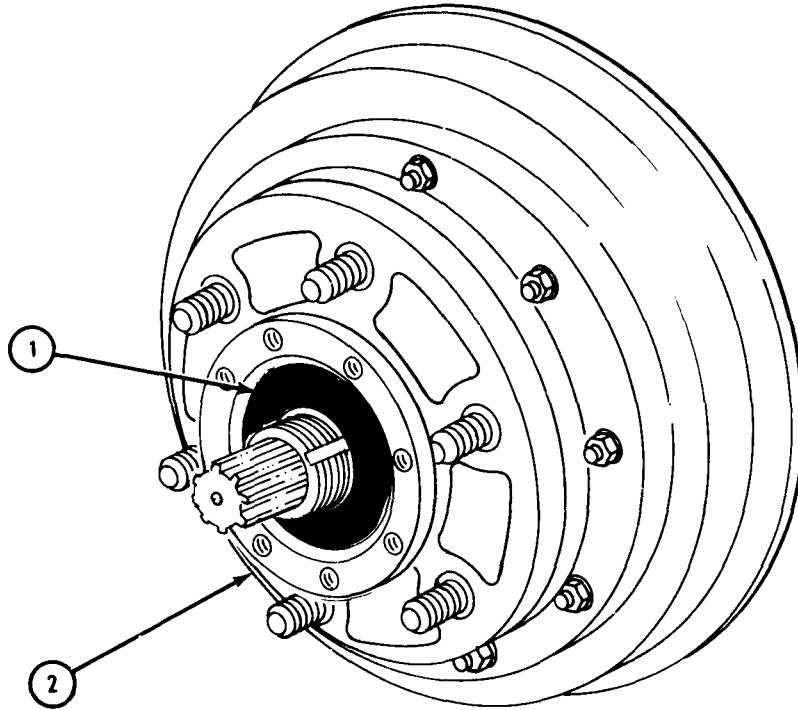

TA 047356

c. Replacement.

FRAME 1

CAUTION

Do not slide seal lip over threaded end of spindle to prevent damage to seal.

Soldiers 1. Put hub and drum assembly (1) on spindle (2).

A and B

GO TO FRAME 2

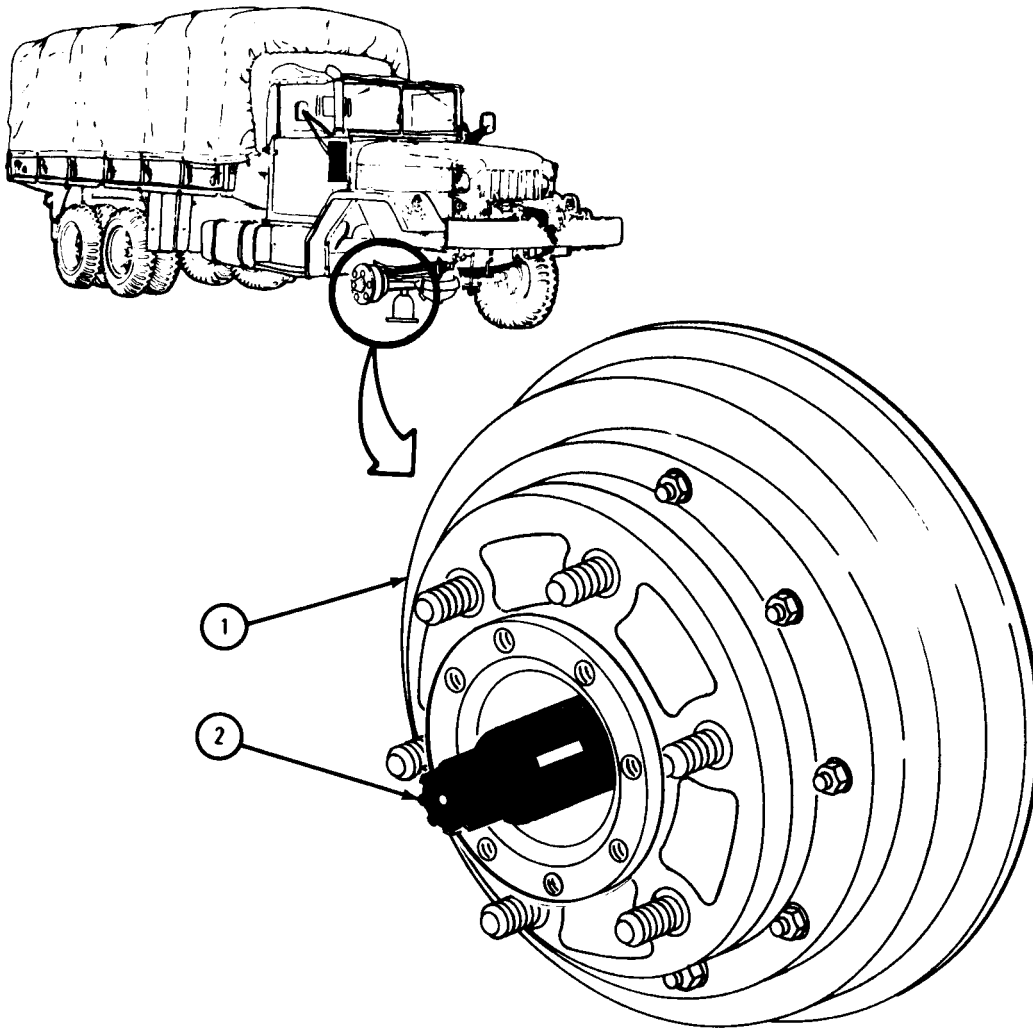

TA 047620

FRAME 2

1. Clean, inspect, and lubricate wheel bearing cone (1). Refer to para 14-6.
2. Put outer wheel bearing cone (1) in hub and drum assembly (2).
3. Using wheel bearing nut wrench, screw on adjusting nut (3).

GO TO FRAME 3

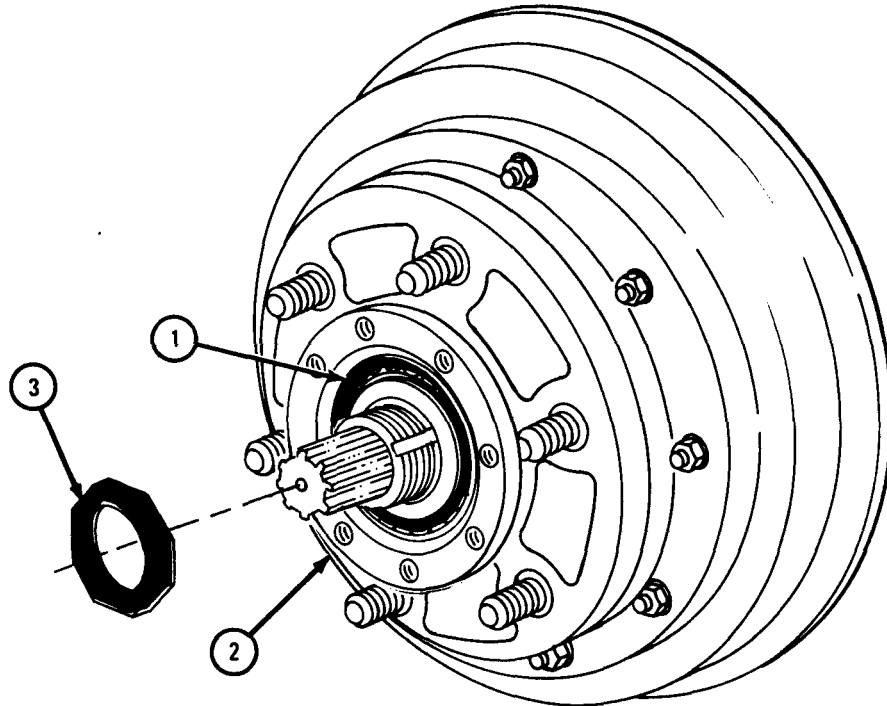

TA 047617

FRAME 3

1. Check brake adjustment. Refer to para 13-9.
2. Replace front wheel. Refer to TM 9-2320-209-10.
3. While turning wheel (1) and using wheel bearing nut wrench, tighten adjusting nut (2) until wheel binds.
4. Using wheel bearing nut wrench, back off adjusting nut (2) 1/8 turn.
5. Put one hand on bottom and one hand on top of wheel (1). Push with one hand and pull with the other hand. If wheel bearing (3) is adjusted correctly, wheel should have very little wobble.

GO TO FRAME 4

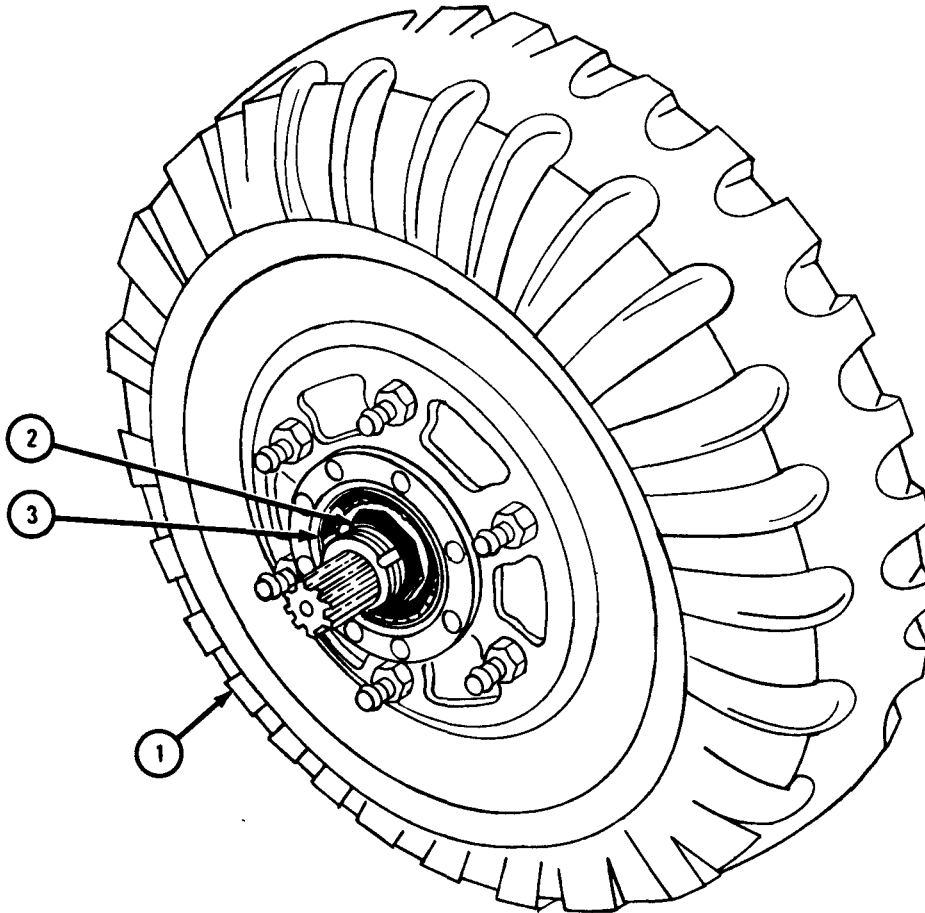

TA 047616

FRAME 4

1. Put on adjusting nut lockwasher (1).
2. Using wheel bearing nut wrench and socket handle, screw on locknut (2).
Using torque wrench, tighten locknut to 100 to 150 pound-feet.
3. Using hammer and punch, bend tabs on adjusting nut lockwasher (1) over
adjusting nut (3) and locknut (2).
4. Jack down wheel. Refer to TM 9-2320-209-10.

GO TO FRAME 5

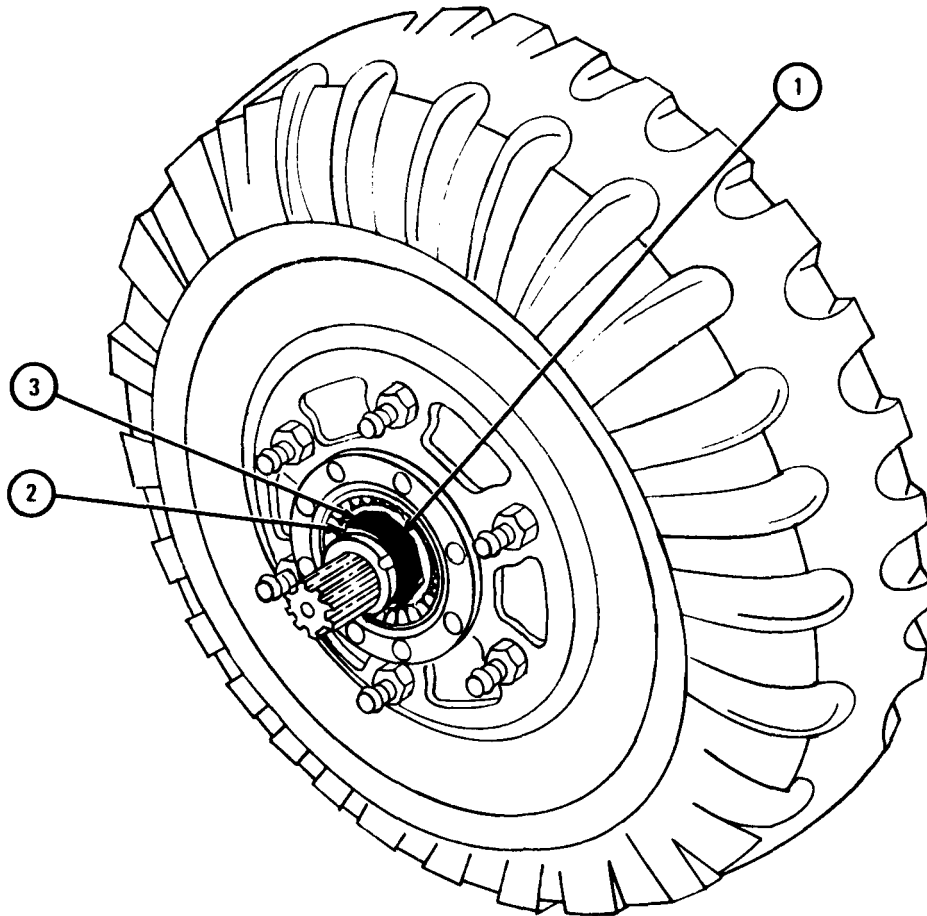

TA 047622

FRAME 5

1. Aline screw holes in flange (1), flange gasket (2), and hub (3).
2. Using 3/4-inch wrench, screw in eight capscrews and eight lockwashers (4).
3. Using torque wrench and 3/4-inch socket wrench, tighten eight capscrews (4) evenly to 85 to 95 pound-feet.

END OF TASK

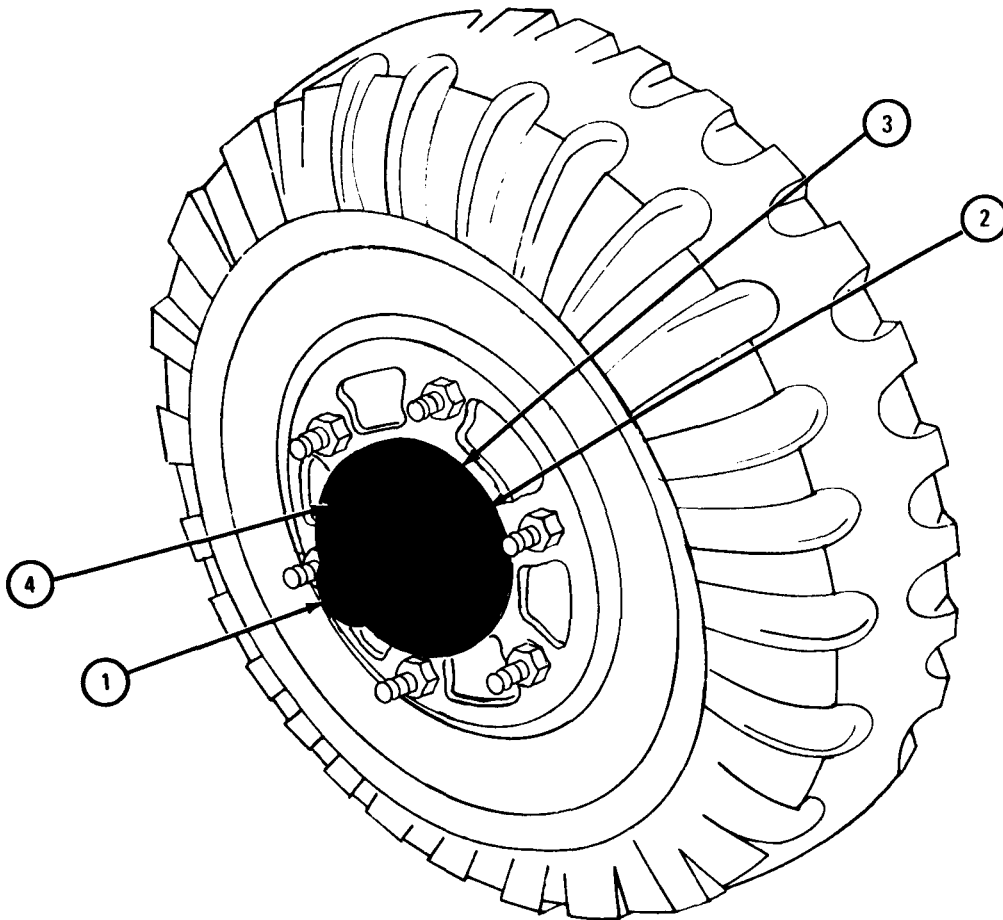

TA 047623

14-5. FRONT AND REAR HUB AND BRAKE DRUM ASSEMBLY REPAIR.

TOOLS: 5/8-inch wrench Arbor press
Brass hammer, medium Medium ballpeen hammer
Wood blocks, 4 X 4 X 18 inches (2) Brass drift

SUPPLIES: Dry cleaning solvent, type II (SD-2), Fed. Spec P-D-680

PERSONNEL: Two

EQUIPMENT CONDITION: Truck parked, engine off, handbrake set.

a. Preliminary Procedure. Remove hub and drum assembly. Refer to para 14-4 for front hub and drum assembly removal. Refer to para 14-9 for rear hub and drum assembly removal.

b. Front Hub and Brake Drum.

(1) Disassembly.

FRAME 1

Soldiers A and B 1. Put drum (1) on top of two wood blocks (2) as shown.

Soldier A 2. Using 9/16-inch wrench, unscrew and take off ten nuts (3), ten washers (4), and inspection cover (5).

3. Using brass hammer, tap hub assembly (6) out of drum (1).

GO TO FRAME 2

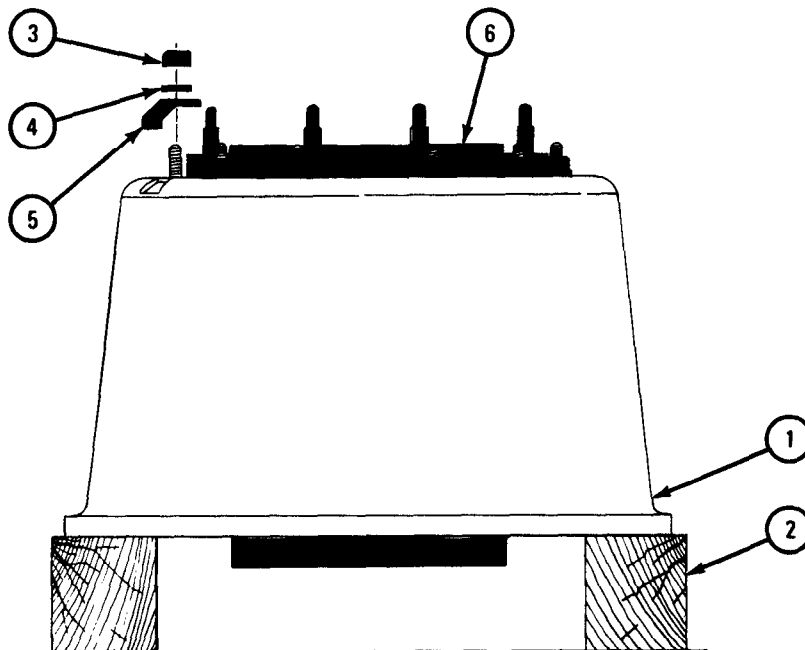

TA 085523

FRAME 2

1. Using hammer and brass drift, tap out and throw away ten studs (1).
2. Using hammer and brass drift, tap out and throw away six wheel studs (2).
3. Using hammer and brass drift, tap hub adapter (3) off hub (4).

END OF TASK

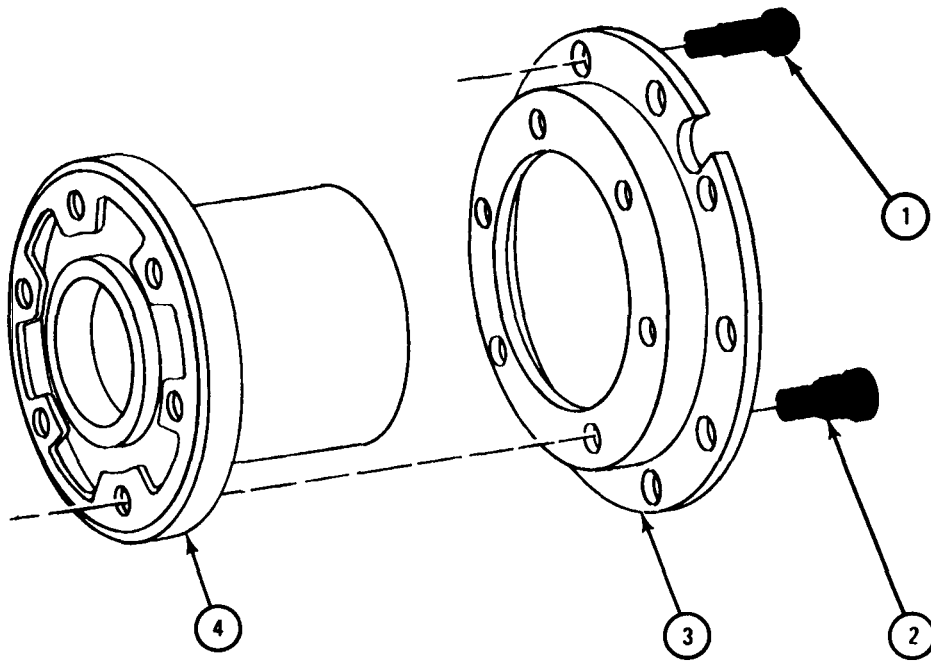

TA 085525

(2) Cleaning, inspection, and repair.

WARNING

Do not use a wire brush or compressed air to clean brake drum. There may be asbestos dust on the drum which can be dangerous to your health.

FRAME 1

WARNING

Dry cleaning solvent is flammable. Do not use near an open flame. Keep a fire extinguisher nearby when solvent is used. Use only in well-ventilated places. Failure to do this may result in injury to personnel and damage to equipment.

1. Clean drum (1) with a brush and water.
2. Clean face (2) of drum (1) with solvent and let it dry.
3. Check that drum (1) is not cracked. If drum is cracked, throw it away and get a new one.
4. Check face (2) of drum (1). If drum is scored as shown, tell direct support maintenance.

GO TO FRAME 2

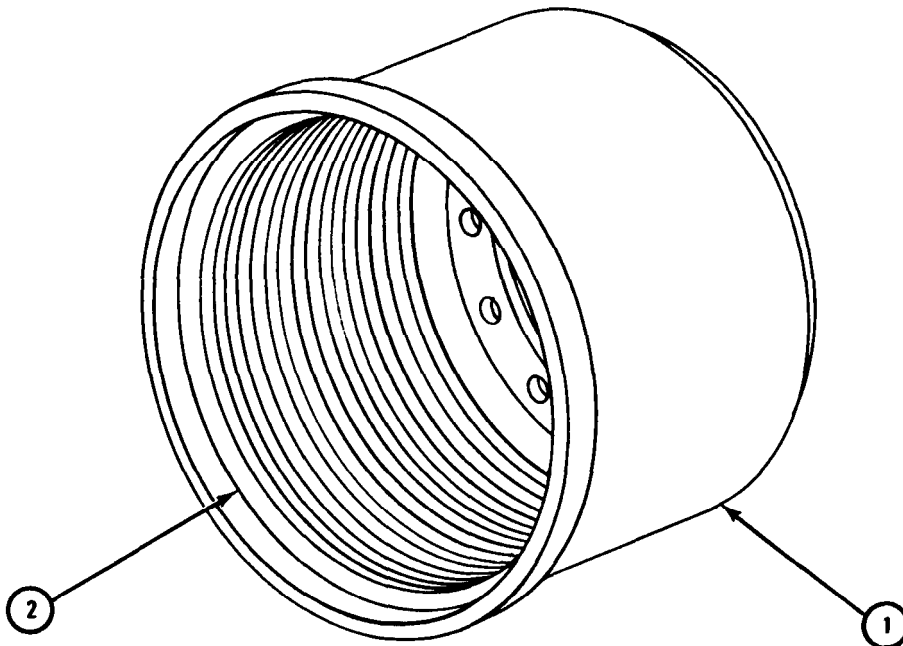

TA 085524

FRAME 2

WARNING

Dry cleaning solvent is flammable. Do not use near an open flame. Keep a fire extinguisher nearby when solvent is used. Use only in well-ventilated places. Failure to do this may result in injury to personnel and damage to equipment.

1. Clean hub (1) with solvent and let it dry.
2. Check that hub (1) is not cracked. If hub is cracked, throw it away and get a new one.
3. Check that inner and outer wheel bearing cups (2) are tight inside hub (1). If cups are loose, remove inner and outer wheel bearing cups (refer to para 14-7) and throw away hub and get a new one.
4. Check that adapter (3) is not cracked or warped. If adapter is damaged, throw it away and get a new one.

END OF TASK

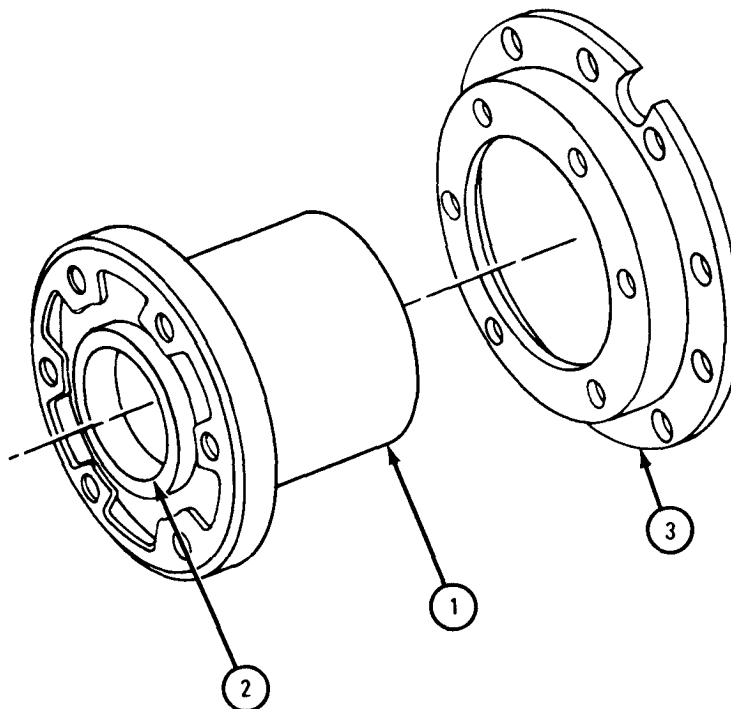

TA 085526

(3) Assembly.

FRAME 1

1. Using hammer and brass drift, tap ten studs (1) into outside row of holes of hub adapter (2).
2. Aline holes in hub adapter (2) with holes in hub (3).
3. Using hammer and brass drift, tap in six wheel studs (4).

GO TO FRAME 2

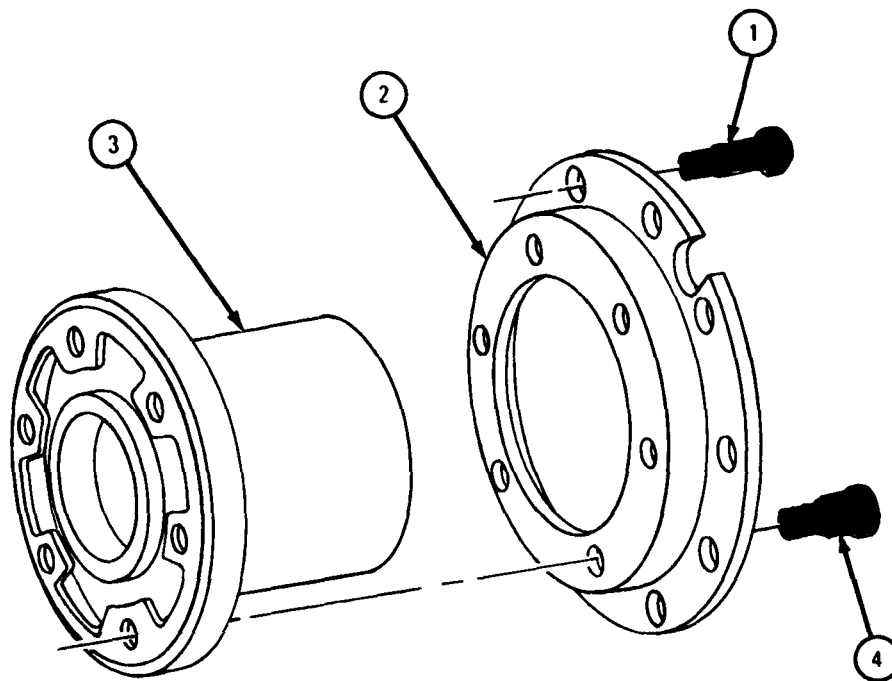

TA 085527

FRAME 2

- Soldiers A and B
1. Aline ten shorter studs on hub (1) with holes in drum (2). Put hub into drum.
 2. Put inspection cover (3) on stud next to inspection hole in drum (2), so hole is covered.
 3. Using 9/16-inch wrench, screw on and evenly tighten ten washers (4) and nuts (5).

NOTE

Follow-on Maintenance Action Required:

Replace front hub and drum assembly. Refer to para 14-4.

END OF TASK

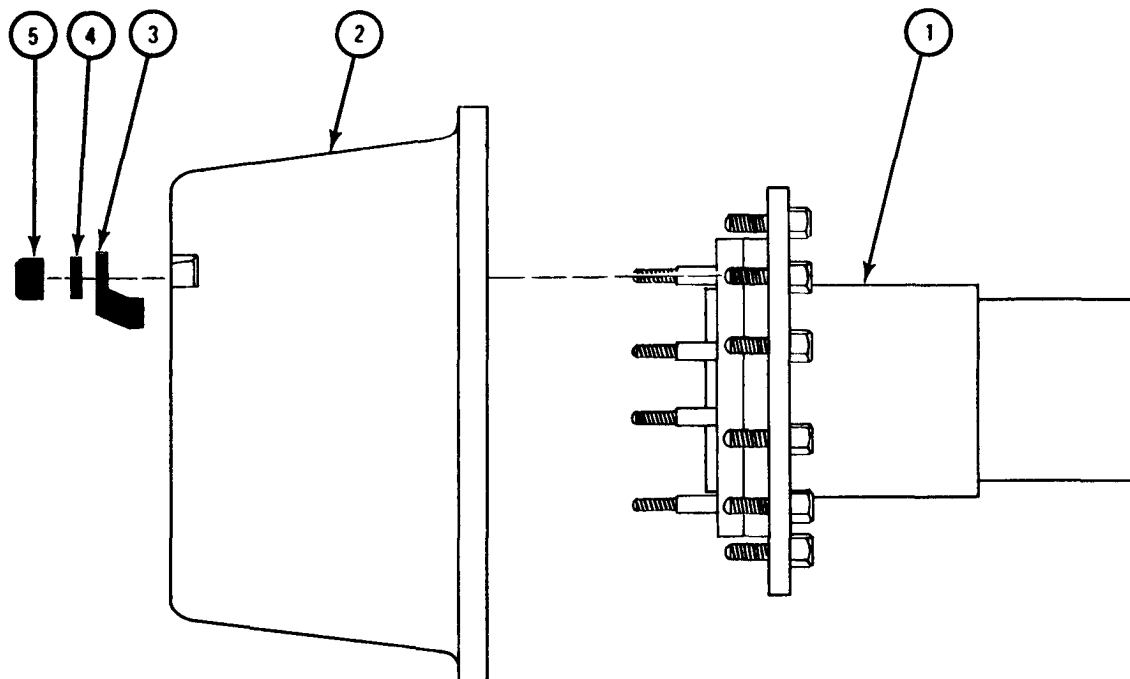

TA 085528

c. Rear Hub and Brake Drum.

(1) Disassembly.

FRAME 1

Soldiers A and B 1. Put drum (1) on top of two wood blocks (2) as shown.

Soldier A 2. Using 9/16-inch wrench, unscrew and take off ten nuts (3) and washers (4). Take off inspection cover (5).

3. Using brass hammer, tap hub assembly (6) out of drum (1).

GO TO FRAME 2

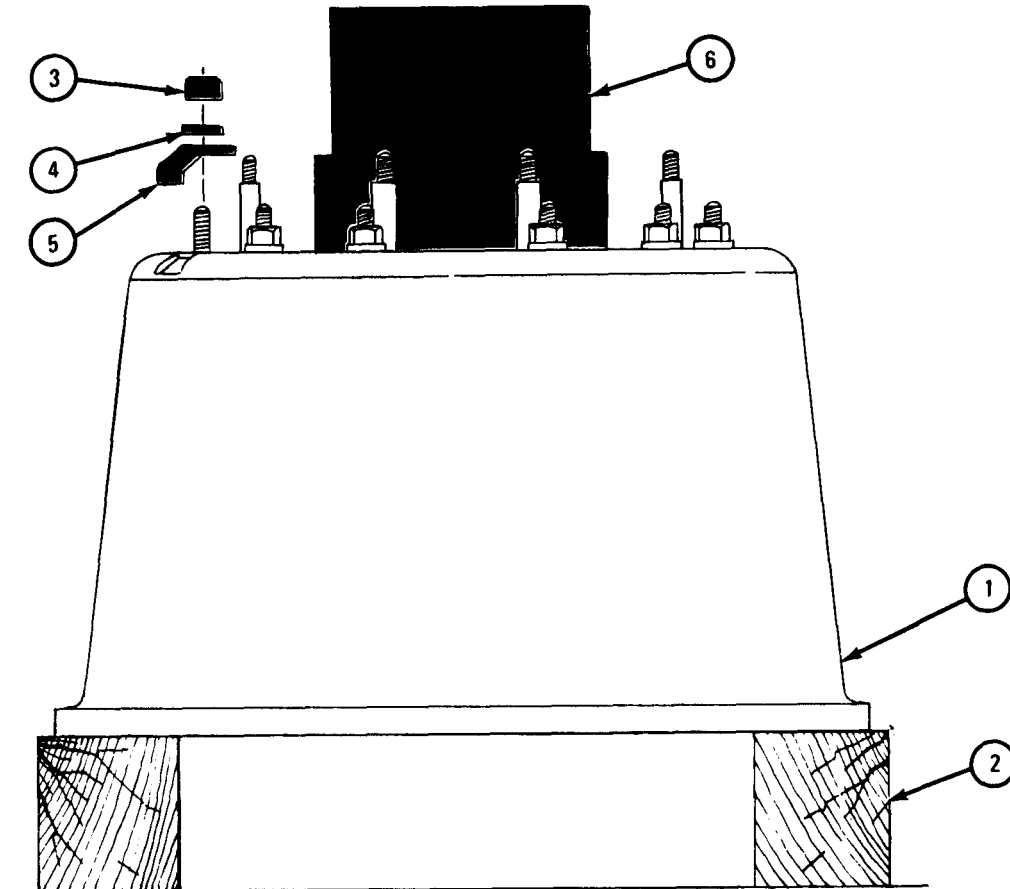

TA 085529

FRAME 2

1. Using hammer and brass drift, tap out and throw away ten studs (1). Take off deflector (2).
2. Using 3/4-inch socket wrench and ratchet, unscrew and take out eight cap-screws (3) and washers (4). Using hammer and brass drift, tap off adapter (5).
3. Using hammer and brass drift, tap out and throw away six wheel studs (6).

END OF TASK

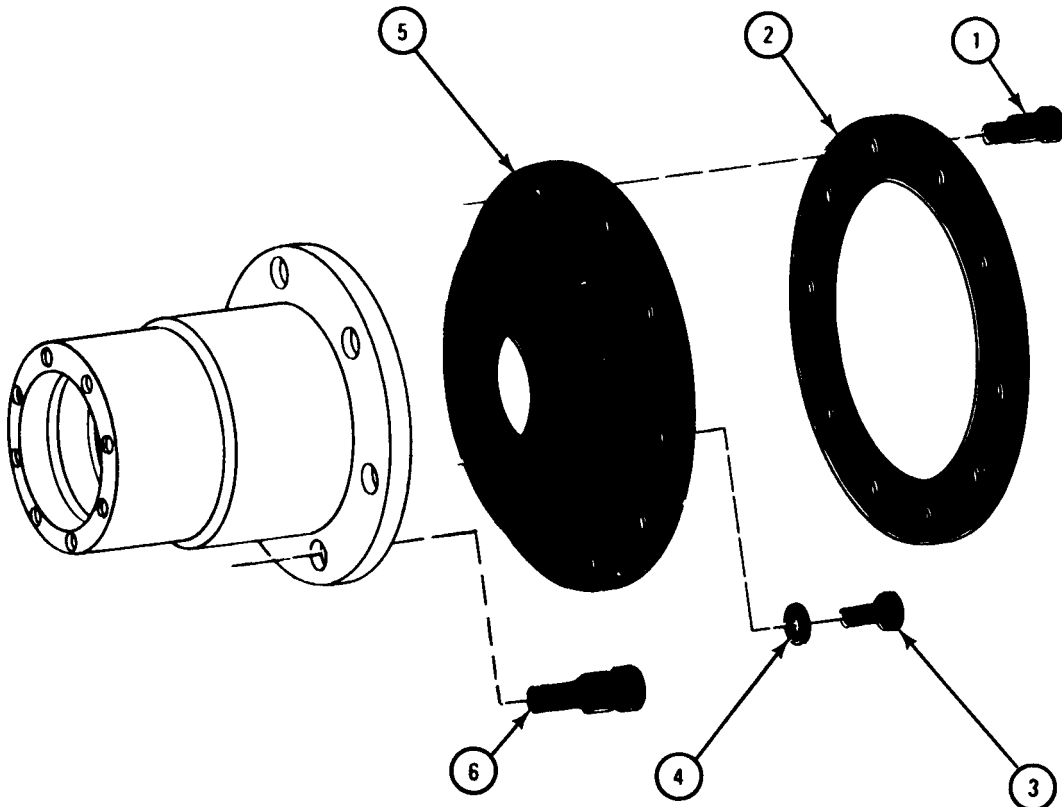

TA 085530

(2) Cleaning, inspection, and repair.

WARNING

Do not use a wire brush or compressed air to clean brake drum (1). There may be asbestos dust on the drums which can be dangerous to your health.

Dry cleaning solvent is flammable. Do not use near an open flame. Keep a fire extinguisher nearby when solvent is used. Use only in well-ventilated places. Failure to do this may result in injury to personnel and damage to equipment.

FRAME 1

1. Clean drum with a brush and water.
2. Clean face (2) of drum (1) with solvent and let it dry.
3. Check that drum (1) is not cracked. If drum is cracked, throw it away and get a new one.
4. Check that face (2) of drum (1) is not scored as shown. If drum is scored, tell direct support maintenance.

GO TO FRAME 2

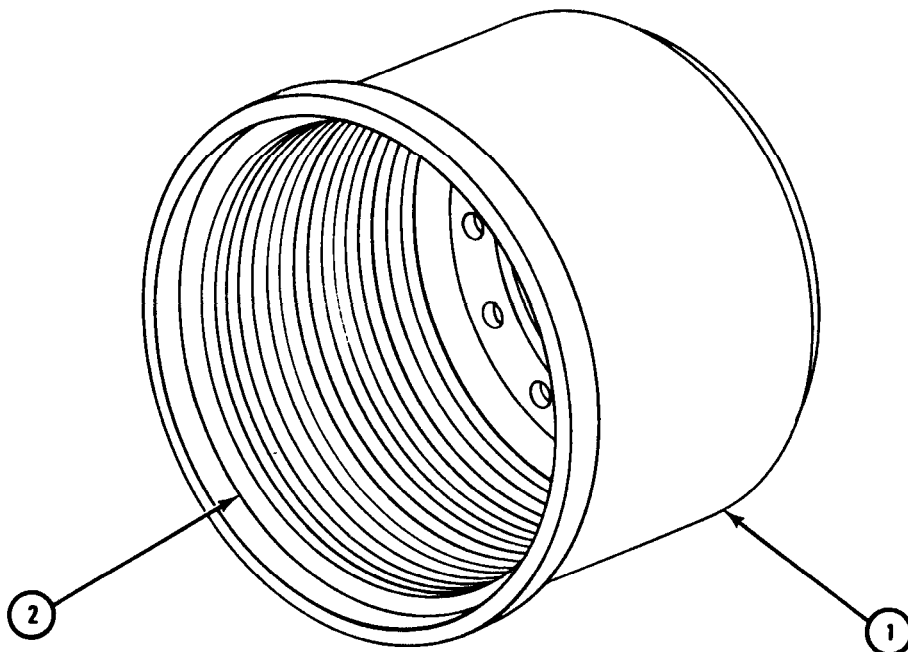

TA 085524

FRAME 2

1. Clean hub (1) with solvent and let it dry.
2. Check that hub (1) is not cracked. If hub is cracked, throw it away and get a new one.
3. Check that inner and outer wheel bearing cups (2) are tight inside hub (1). If cups are loose, remove inner and outer wheel bearing cups (refer to para 14-10) and throw away hub and get a new one.
4. Check that adapter (3) and deflector (4) are not cracked or warped. If parts are damaged, throw them away and get new ones.

END OF TASK

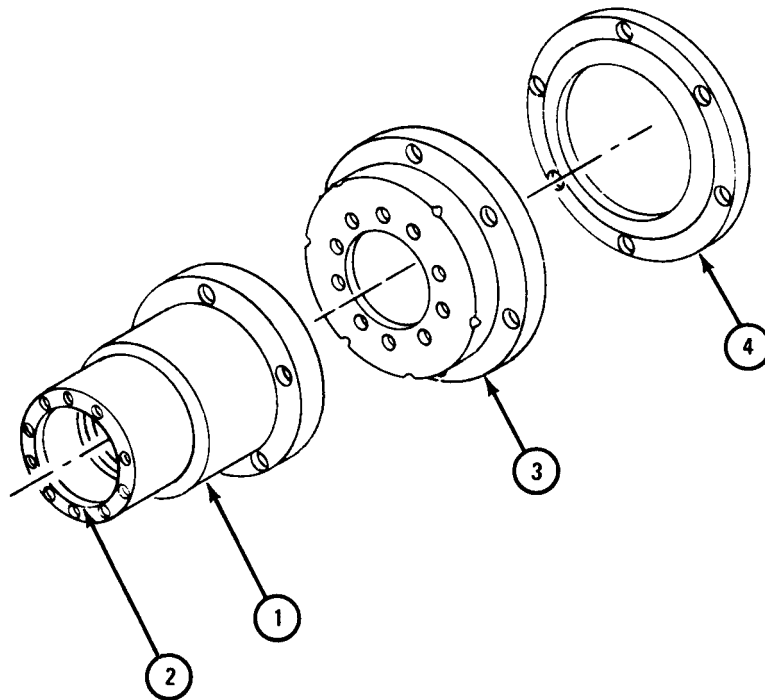

TA 085531

(3) Assembly.

FRAME 1

1. Using hammer and brass drift, tap in six wheel studs (1).
2. Aline inside row of holes in adapter (2) with threaded screw holes in hub (3).
3. Using 3/4-inch socket wrench and ratchet, screw in and tighten eight capscrews (4) with washers (5).

Soldiers
A and B

4. Aline ten holes in deflector (6) with holes in adapter (2).
5. Using hammer and brass drift, tap in ten studs (7).

GO TO FRAME 2

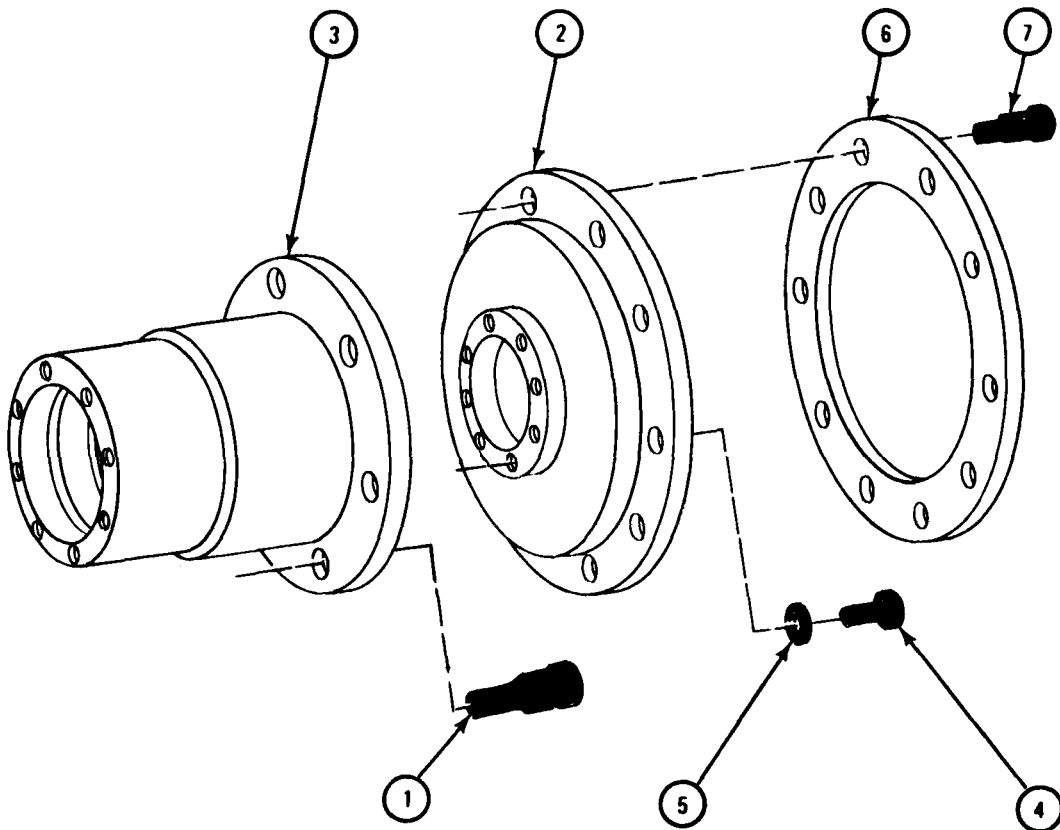

TA 085532

FRAME 2

- Soldiers A and B
1. Aline ten shorter studs on hub (1) with holes in drum (2). Put hub into drum.
 2. Put inspection cover (3) on stud next to inspection hole in drum (2) so hole is covered.
 3. Using 9/16-inch wrench, screw on and evenly tighten ten washers (4) and nuts (5).

NOTE

Follow-on Maintenance Action Required:

Replace rear hub and drum assembly. Refer to para 14-9.

END OF TASK

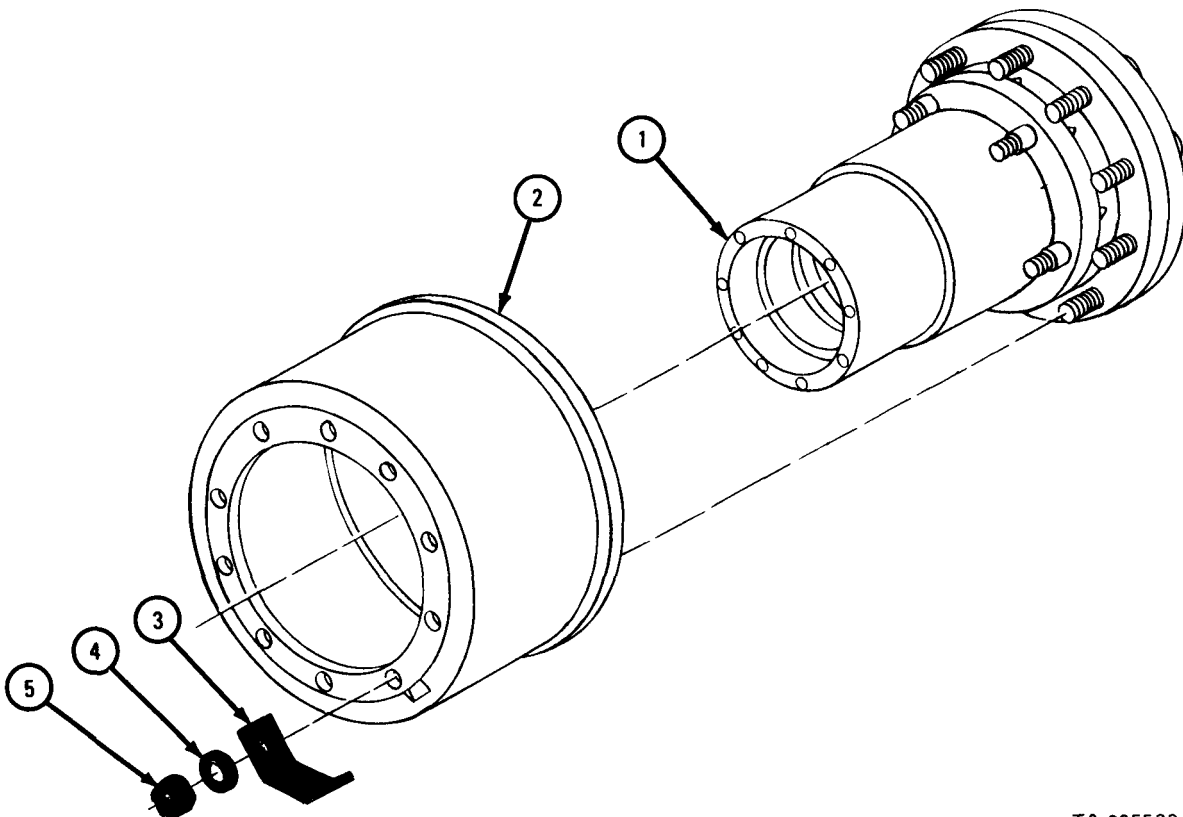

TA 085533

14-6. FRONT WHEEL BEARING CONES AND SEALS REMOVAL AND REPLACEMENT FOR SERVICE.

TOOLS: Portable bearing lubricator
Hand grease gun
Wheel bearing remover and replacer, pn 7082863
Drop light
Prybar

SUPPLIES: Artillery and automotive grease, type GAA, MIL-G-10924
Solvent, dry cleaning, type II (SD-2), Fed. Spec P-D-680
Clean rags
Hub bearing inner seal

PERSONNEL: One

EQUIPMENT CONDITION: Truck parked on level ground, engine off, handbrake set.

- a. Preliminary Procedure. Remove front wheel and brake drum assembly. Refer to para 14-4.
- b. Removal.

FRAME 1

NOTE

Outer wheel bearing cone is removed during front wheel and drum assembly removal. If bearing is tight, use prybar to loosen.

- 1. Take bearing (1) off spindle (2).
- 2. Take seal (3) off spindle (2) and throw away seal.

END OF TASK

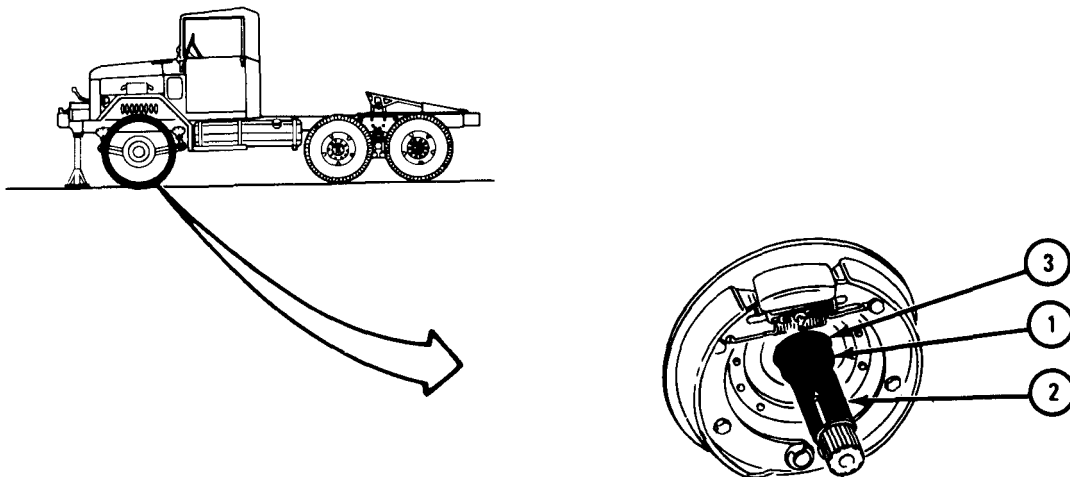

TA 083252

c. Cleaning.

NOTE

This task is for both inner and outer wheel bearing cones.

FRAME 1

WARNING

Dry cleaning solvent is flammable. Do not use near an open flame. Keep a fire extinguisher nearby when solvent is used. Use only in well-ventilated places. Failure to do this may result in injury to personnel and damage to equipment.

NOTE

All old lubricant must be taken off bearing cones (1) during cleaning. Soak bearing cones as long as needed to take off all old lubricant.

1. Soak bearing cone (1) in solvent.
2. Rinse bearing cone (1) in clean solvent.

WARNING

Do not dry bearing with compressed air. Spinning bearings may explode and cause serious injury to personnel.

3. Let bearing cone (1) dry.
4. Using clean rags, wipe all old grease from inside hub (2).

END OF TASK

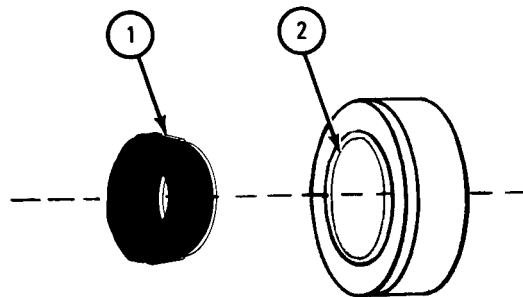

TA 050472

d. Inspection.

FRAME 1

NOTE

Inner and outer wheel bearing cups are inside of hub.
If wheel bearing cone (1) or cup (4) needs replacing,
do wheel bearing cones and seals removal and replace-
ment. Refer to para 14-6f.

1. Place drop light behind bearing assembly.
2. Hold wheel bearing cone (1) and turn a inner race (2) slowly.
3. Check that bearing rollers (3) and wheel bearing cone (1) have no cracks, flaking, pitting or long or deep scratches.
4. Check that wheel bearing cone (1) has not overheated. Wheel bearing cone will turn blue where it has overheated.
5. Check that bearing cups (4) have no dents or small depressions.

NOTE

If bearing rollers (3) are damaged, throw away bearing
cone (1) and get a new one.

6. Check that bearing cups (4) and bearing rollers (3) are not splintered or chipped.
7. Throw away damaged parts and get new ones.

END OF TASK

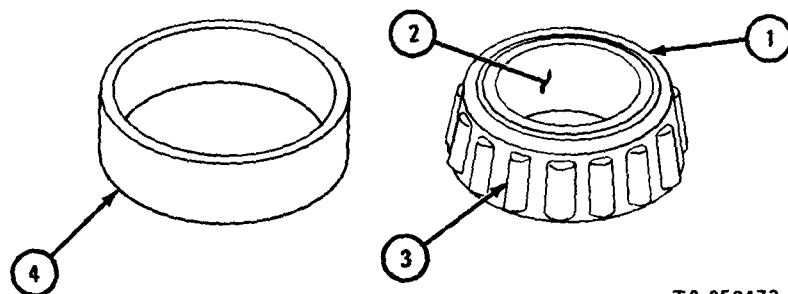

TA 050473

e. Lubrication.**FRAME 1**

1. Put wheel bearing cone (1) into portable bearing lubricator as shown.
2. Using hand grease gun, grease wheel bearing cone (1) until grease comes out of sides of bearing.

END OF TASK

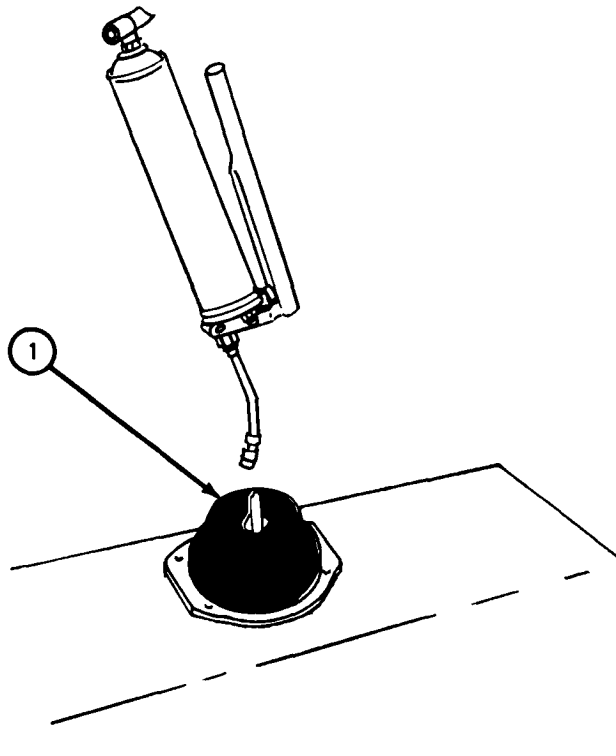

TA 082024

f. Replacement.

FRAME 1

1. Put seal (1) on spindle (2).
2. Using bearing replacer, put bearing (3) on spindle (2).
3. Using clean rag, wipe all grease from seal (1) and spindle (2).

NOTE

Follow-on Maintenance Action Required:

Replace front wheel and brake drum assembly. Refer to para 14-4.

END OF TASK

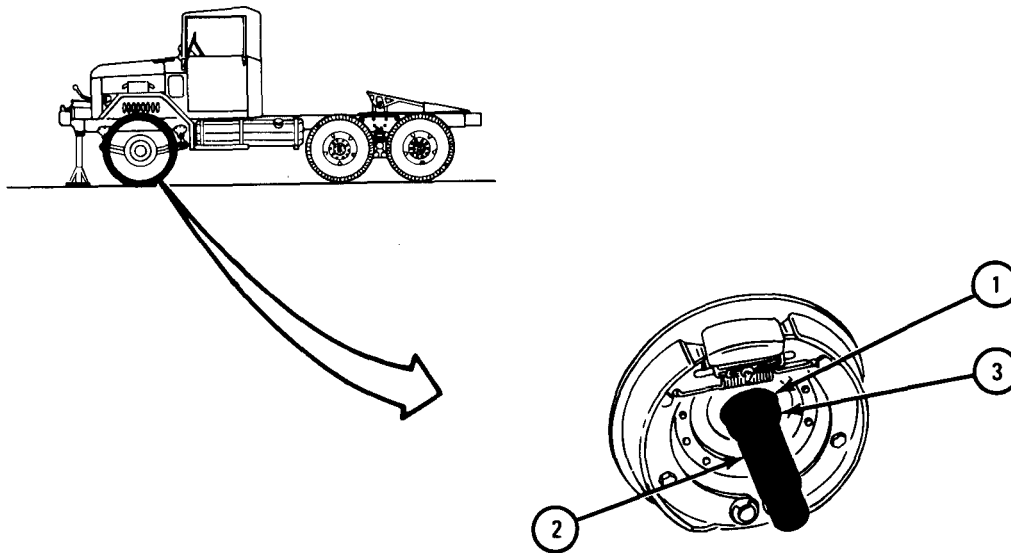

TA 083254

14-7. FRONT INNER AND OUTER WHEEL BEARINGS AND SEALS REMOVAL AND REPLACEMENT.

TOOLS: Portable bearing lubricator
 Hand grease gun
 Ballpeen hammer
 3/4 x 10-inch brass drift
 Prybar

SUPPLIES: Artillery and automotive grease, type GAA, MIL-G-10924
 Solvent, dry cleaning, type II (SD-2), Fed. Spec P-D-680
 Clean rags

PERSONNEL: One

EQUIPMENT CONDITION: Truck parked, engine off, handbrake set.

a. Preliminary Procedure. Remove front hub and brake drum assembly. Refer to para 14-4.

b. Removal.

NOTE

Outer wheel bearing cone is removed during front hub and drum assembly removal.

FRAME 1

1. Using prybar, pry bearing (1) off wheel hub spindle (2).
2. Using prybar, pry and slide off seal (3). Throw away seal.

GO TO FRAME 2

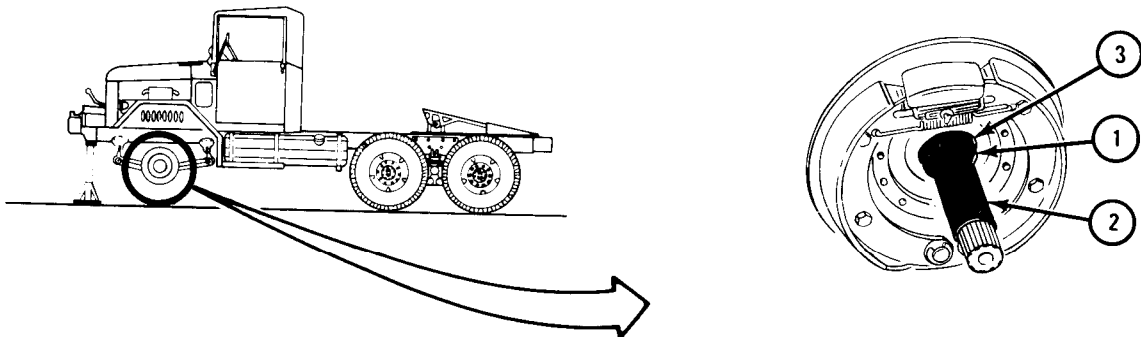

TA 047618

FRAME 2

1. Working through rear of hub and drum assembly (1), using hammer and brass drift, tap out outer wheel bearing cup (2).

2. Turn over hub and drum assembly (1).

GO TO FRAME 3

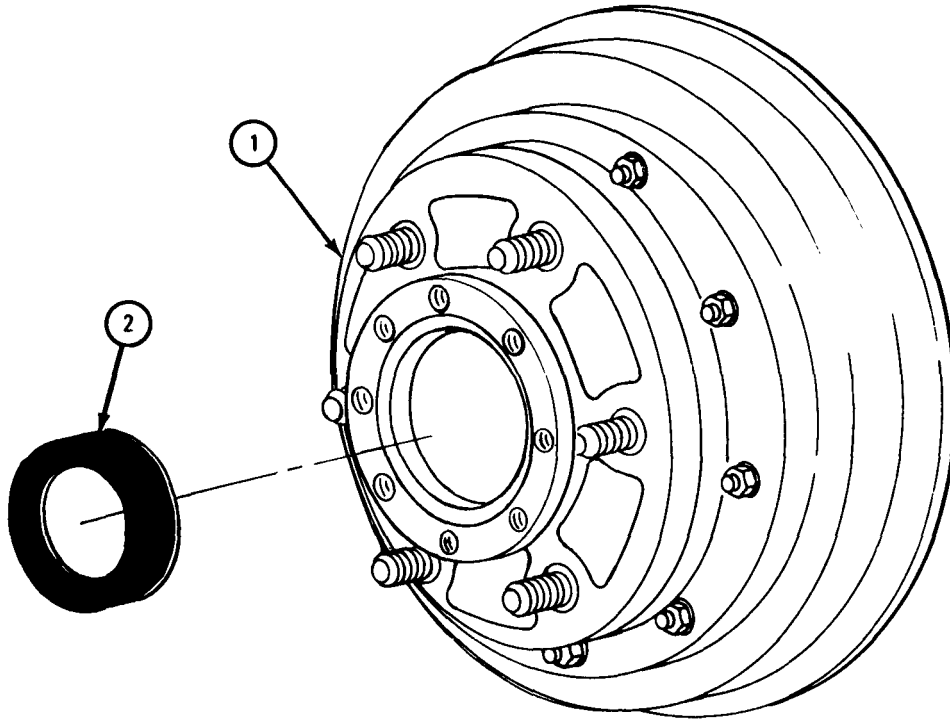

TA 082203

FRAME 3

1. Working through front of hub and drum assembly (1), using hammer and brass drift, tap out inner wheel bearing cup (2).

END OF TASK

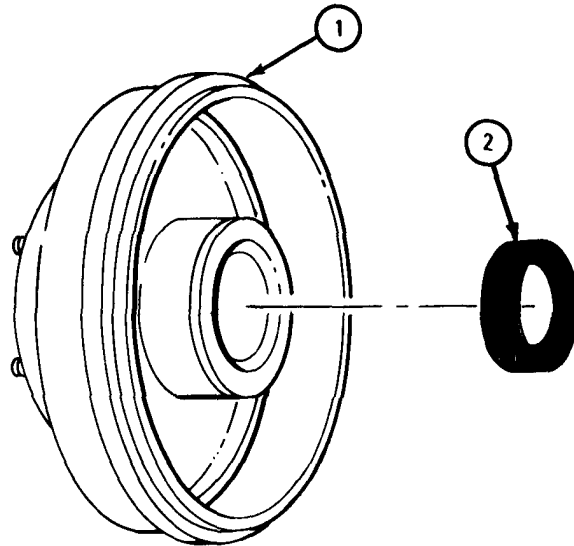

TA 082204

c. Cleaning.

NOTE

This task is for both inner and outer wheel bearing cones.

FRAME 1

WARNING

Dry cleaning solvent is flammable. Do not use near an open flame. Keep a fire extinguisher nearby when solvent is used. Use only in well-ventilated places. Failure to do this may result in injury to personnel and damage to equipment.

NOTE

All old lubricant must be taken off bearings during cleaning. Soak bearing as long as needed to take off all old lubricant.

1. Soak bearing cone (1).
2. Rinse bearing cone (1) in clean solvent.

WARNING

Do not dry bearing with compressed air. Spinning bearings may explode and cause serious injury to personnel.

3. Let bearing cone (1) air dry.
4. Using clean rags, wipe all old grease from inside hub (2).

END OF TASK

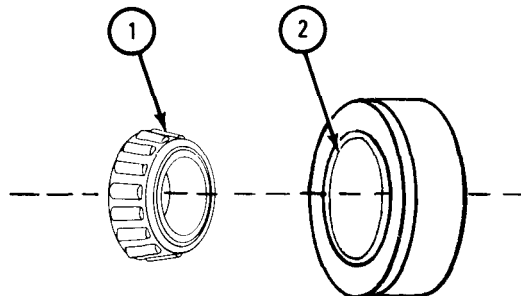

TA 050472

d. Inspection.**FRAME 1**

1. Place drop light behind bearing assembly.
2. Hold wheel bearing cone (1) and turn inner race (2) slowly.
3. Check that bearing rollers (3) and wheel bearing cone (1) have no cracks, flaking, pitting or long or deep scratches.
4. Check that wheel bearing cone (1) has not overheated. Wheel bearing cone will turn blue where it has overheated.
5. Check that bearing cups (4) have no dents or small depressions.

NOTE

If bearing rollers (3) are damaged, throw away bearing cone (1) and get a new one.

6. Check that bearing cups (4) and bearing rollers (3) are not splintered or chipped.
7. Throw away damaged parts and get new ones.

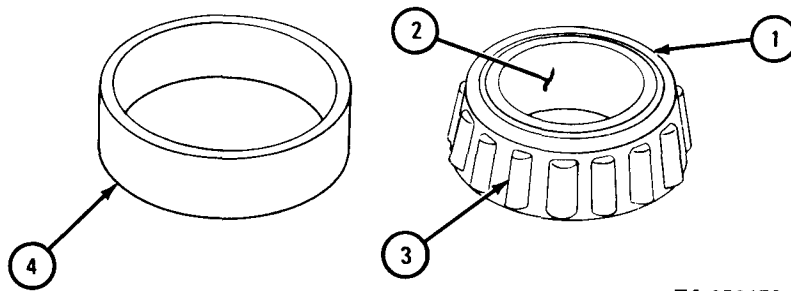
END OF TASK

TA 050473

e. Lubrication.

FRAME 1

1. Put wheel bearing cone (1) into portable bearing lubricator as shown.
2. Using hand grease gun, grease wheel bearing cone (1) until grease comes out of sides of bearing.

END OF TASK

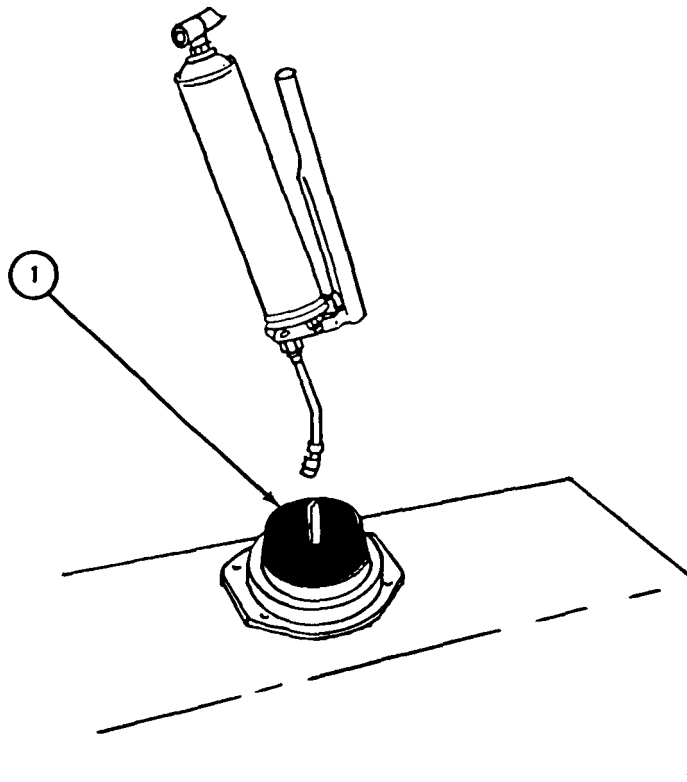

TA 082024

f. Replacement.

FRAME 1

1. Using hammer and brass drift, tap in inner wheel bearing cup (1) until it is seated inside hub (2).
2. Turn over hub and drum assembly (3).

GO TO FRAME 2

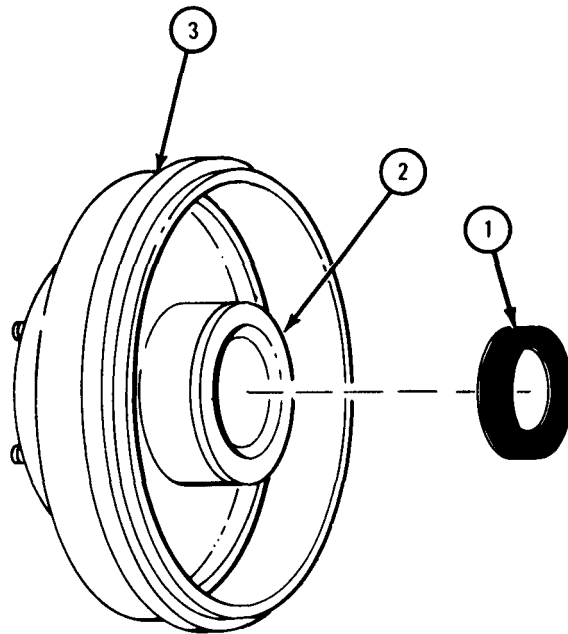

TA 082206

FRAME 2

1. Using hammer and brass drift, tap in outer wheel bearing cup (1) until it is seated inside hub (2).
2. Using clean rag, wipe all grease from hub (2).
3. Turn over hub and drum assembly (3).

GO TO FRAME 3

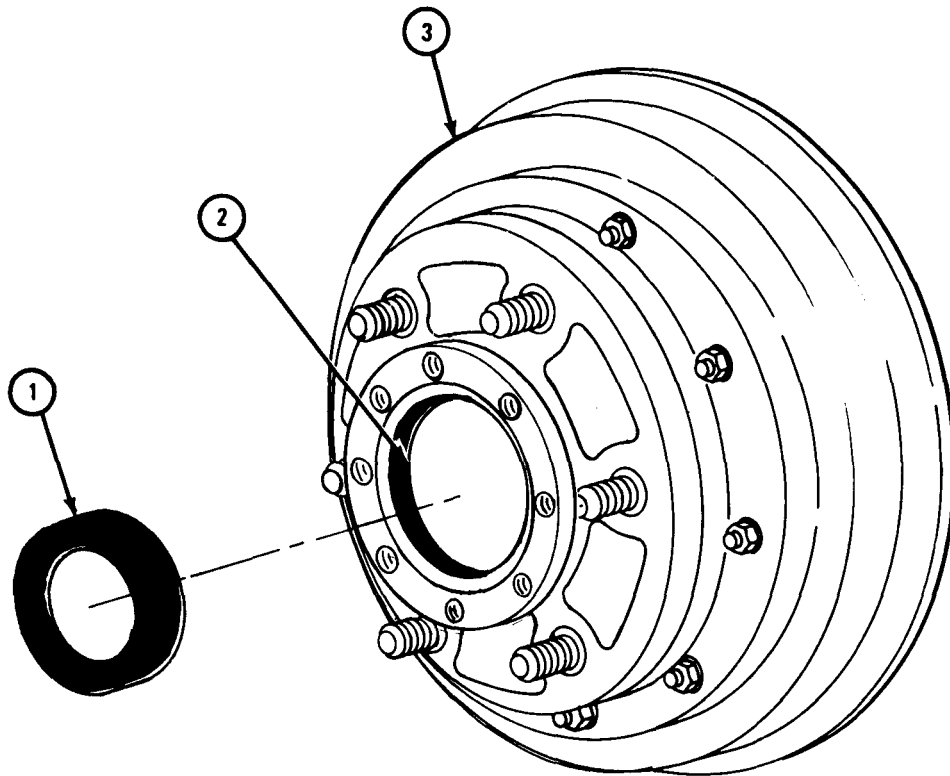

TA 082207

FRAME 3

1. Using hammer and brass drift, tap seal (1) into place on wheel hub spindle (2).
2. Using hammer and brass drift, tap bearing (3) into place with tapered end facing away from wheel hub spindle (2).
3. Using clean rag, wipe all grease from seal (1).

NOTE

Follow-on Maintenance Action Required:

Replace front hub and drum assembly. Refer to para 14-4.

END OF TASK

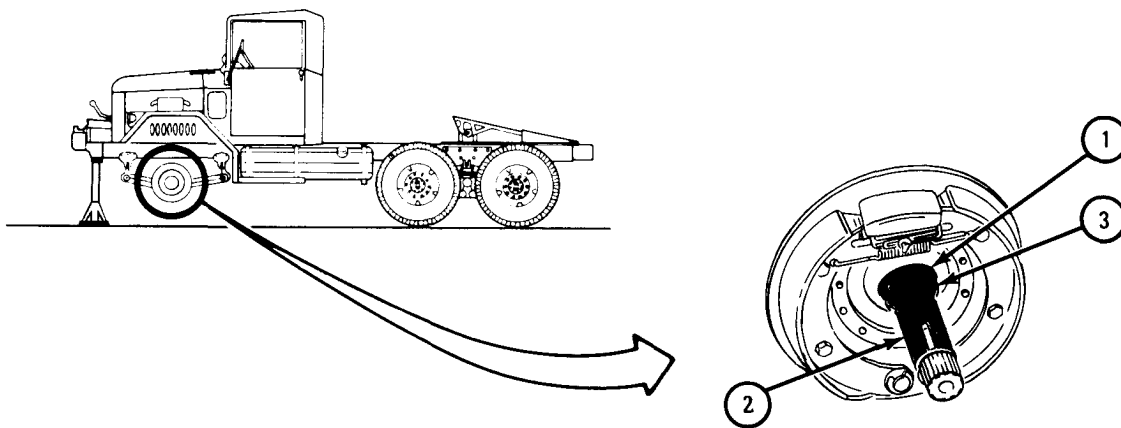

TA 047619

Section III. REAR WHEEL ASSEMBLY

14-8. REAR WHEELS AND BRAKE DRUM ASSEMBLY REMOVAL AND REPLACEMENT.

TOOLS: Wheel bearing nut wrench, Portable bearing lubricator
pn 7076869 Hand grease gun
3/4-inch wrench Wheel lift truck
3/4-inch socket wrench Torque wrench, 150 pound-feet capacity

SUPPLIES: Drive flange gasket
Artillery and automotive grease, type GAA, MIL-G-10924

PERSONNEL: One

EQUIPMENT CONDITION: Truck parked on level ground, engine off, handbrake set.

a. Preliminary Procedure. Jack and support rear axle housing. Refer to Part 1, para 11-3.

b. Removal.

FRAME 1

1. Using 3/4-inch wrench, unscrew and take off eight capscrews (1).
2. Take out axle shaft assembly (2) and gasket (3). Throw away gasket.

GO TO FRAME 2

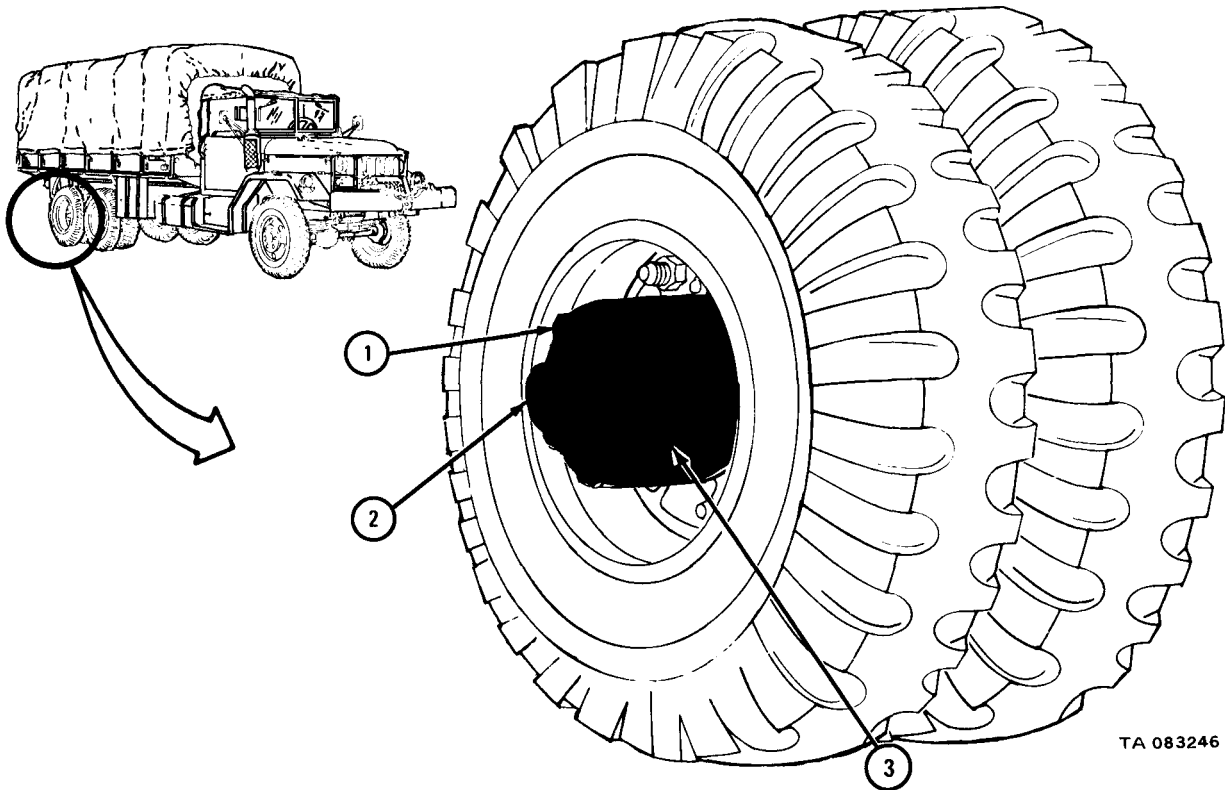

TA 083246

FRAME 2

1. Using hammer and punch, bend up tabs on adjusting nut lockwasher (1) so that locknut (2) can be turned.
2. Using wheel bearing nut wrench and socket handle, unscrew and take off locknut (2). Take off adjusting nut lockwasher (1).

GO TO FRAME 3

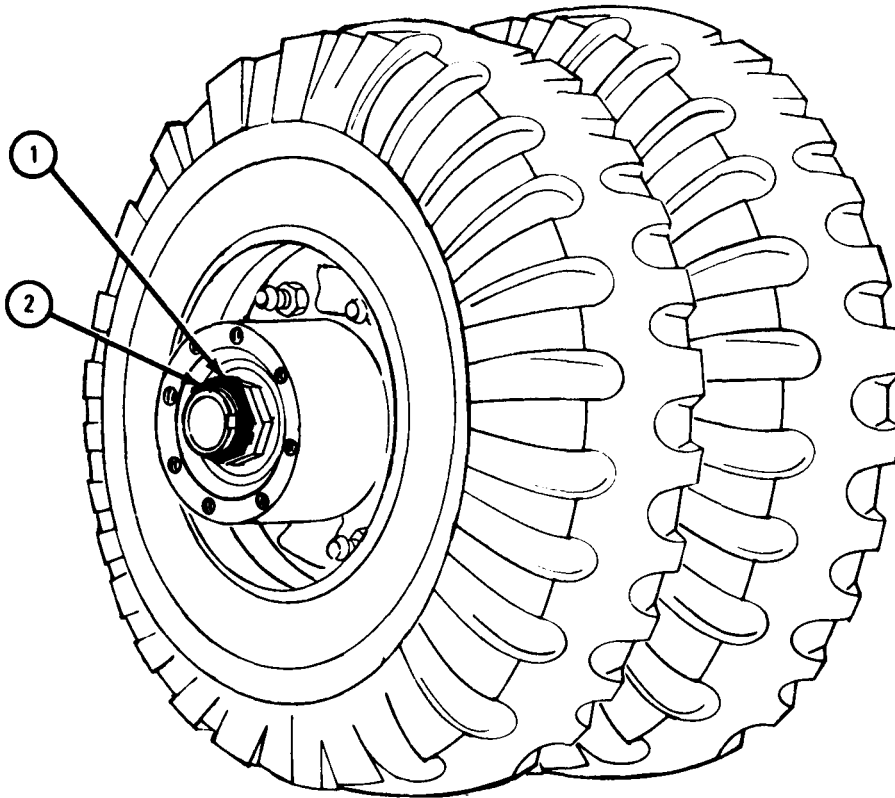

TA 083247

FRAME 3

1. Using wheel bearing nut wrench and socket handle, unscrew and take off adjusting nut (1).

GO TO FRAME 4

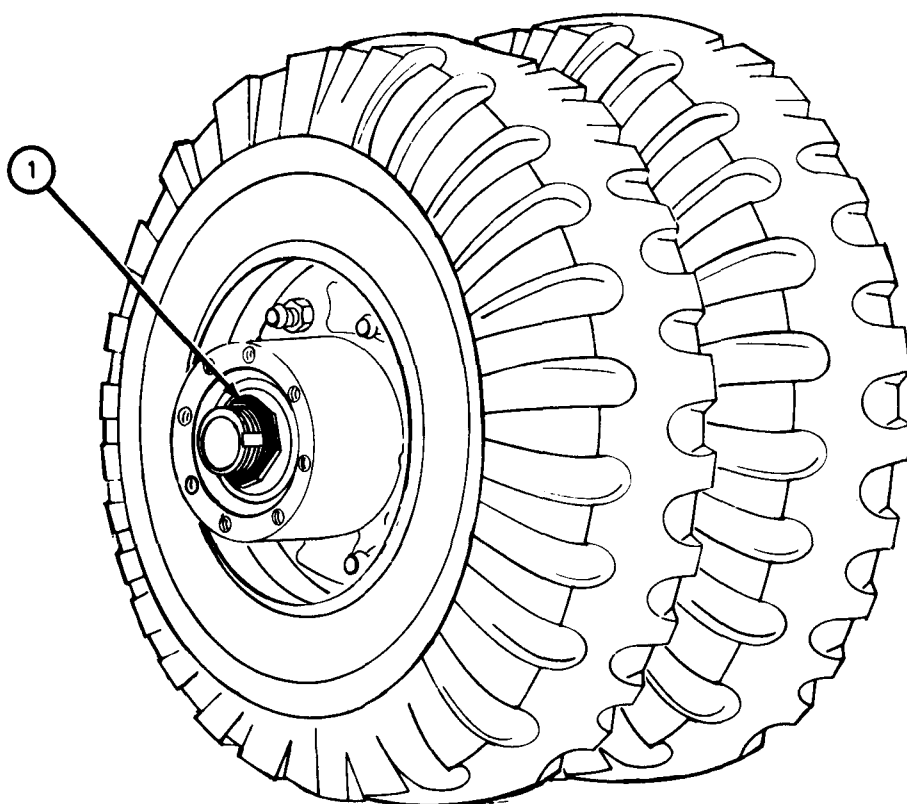

TA 083248

FRAME 4

1. Put wheel lift truck under rear wheels and drum assembly (1) as shown.
2. Jack up wheel lift truck until lift arms just touch tires (2).
3. Shake top of tires (2) until outer wheel bearing cone (3) and outer seal (4) move out of hub (5).
4. Take off outer wheel bearing cone (3) and outer seal (4).
5. Level lift arms on wheel lift truck until rear wheels and drum assembly (1) can be pulled straight off spindle (6).
6. Pull wheel lift truck and rear wheels and drum assembly (1) away from truck.

END OF TASK

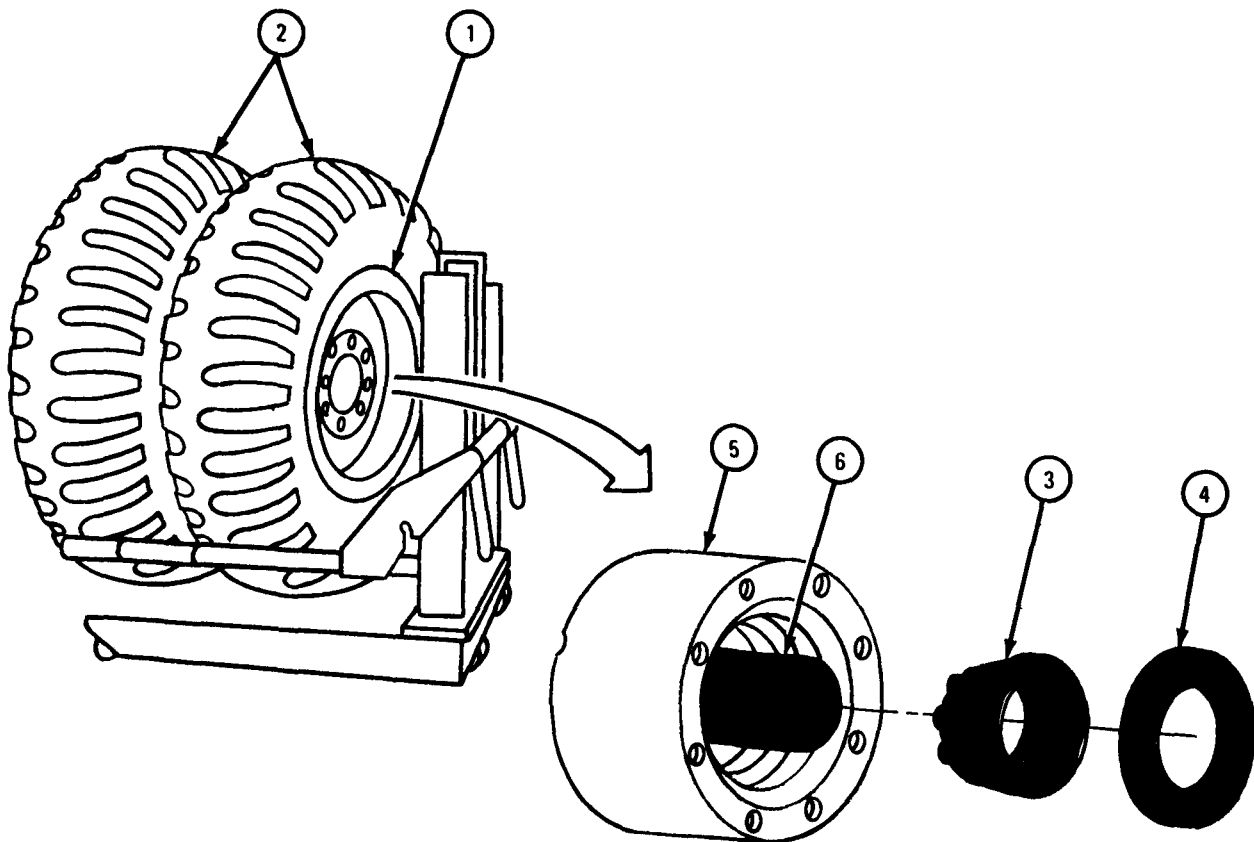

TA 083249

c. Replacement.

FRAME 1

1. Push wheel lift truck with wheels and drum assembly (1) toward truck so that hub (2) goes on spindle (3) as shown.

GO TO FRAME 2

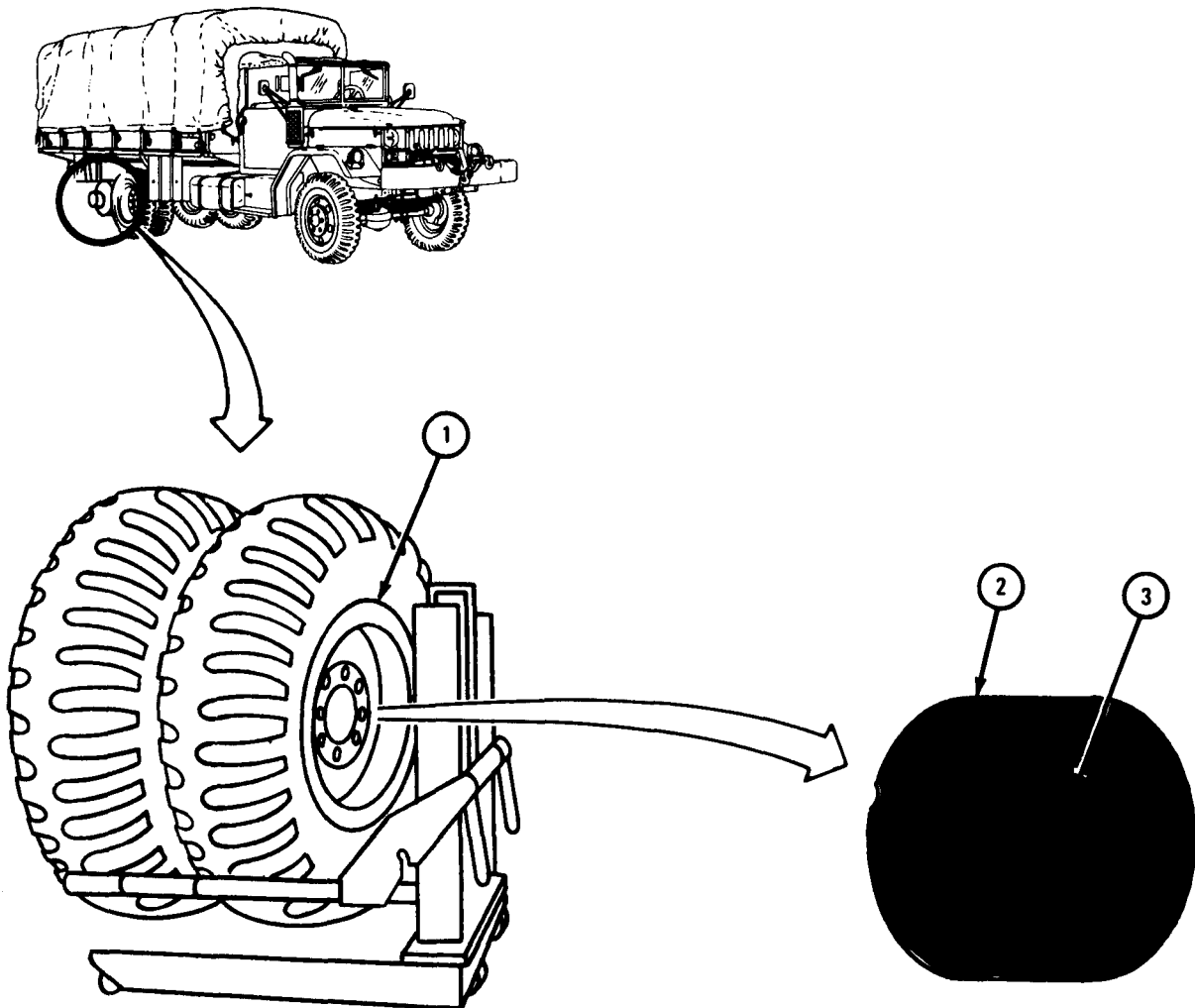

TA 083250

FRAME 2

CAUTION

Do not drag lip of seal over threaded end of spindle.
Seal can be damaged.

1. Using portable bearing lubricator and hand grease gun, grease outer wheel bearing cone (1).
2. Put outer wheel bearing cone (1) and outer seal (2) in hub (3).
3. Using wheel bearing nut wrench and socket handle, screw on adjusting nut (4).
4. Lower wheel lift truck and take it out of the way.

GO TO FRAME 3

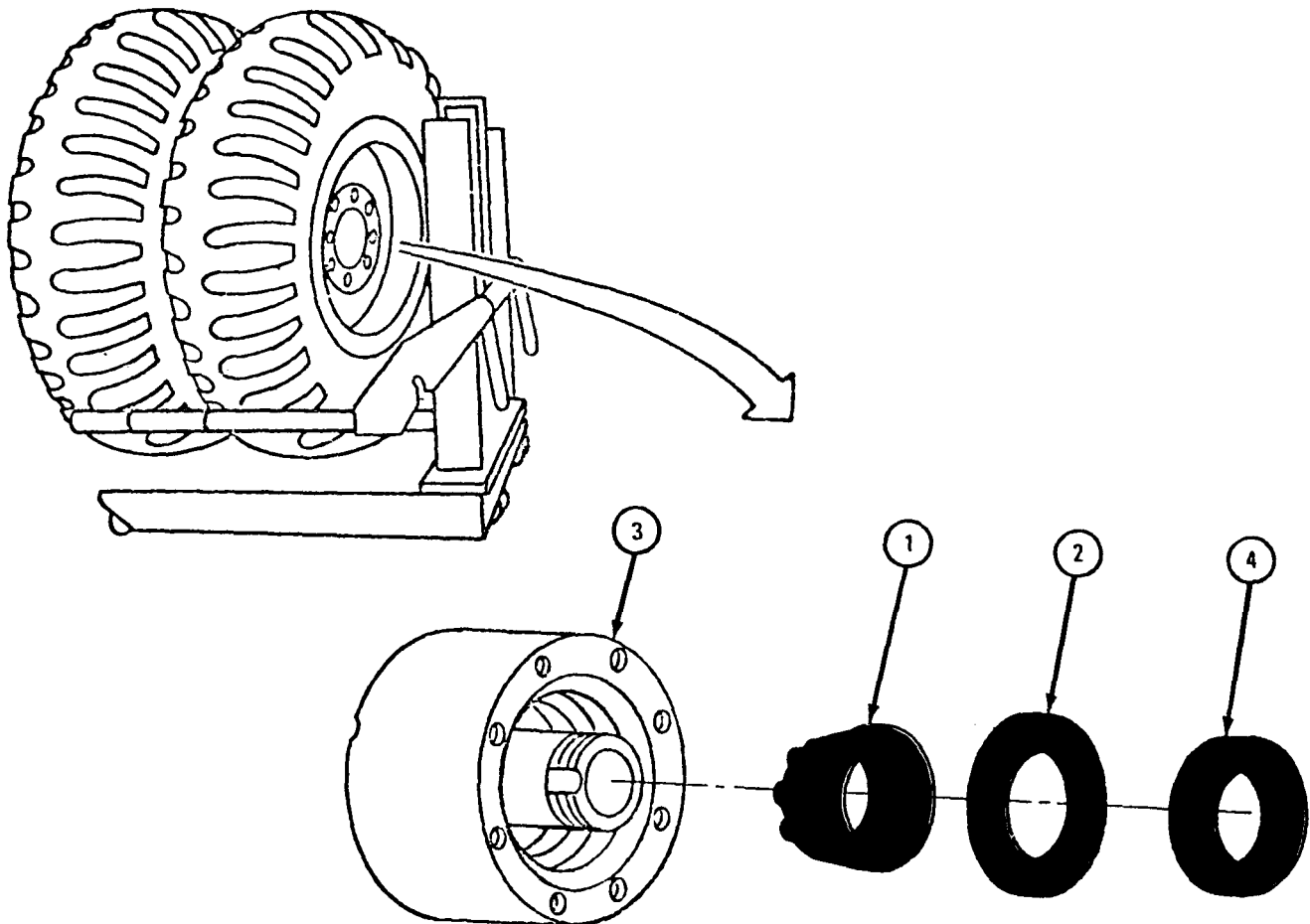

TA 083251

FRAME 3

1. Check brake adjustment. Refer to para 13-9.
2. While turning rear wheels (1) and using wheel bearing nut wrench with socket handle, tighten adjusting nut (2) until wheels bind, then back off adjusting nut 1/8 turn.
3. Put one hand on bottom and one hand on top of wheel (1). Push with one hand and pull with the other hand. If wheel bearing (3) adjustment is correct, there will be very little wobble.

GO TO FRAME 4

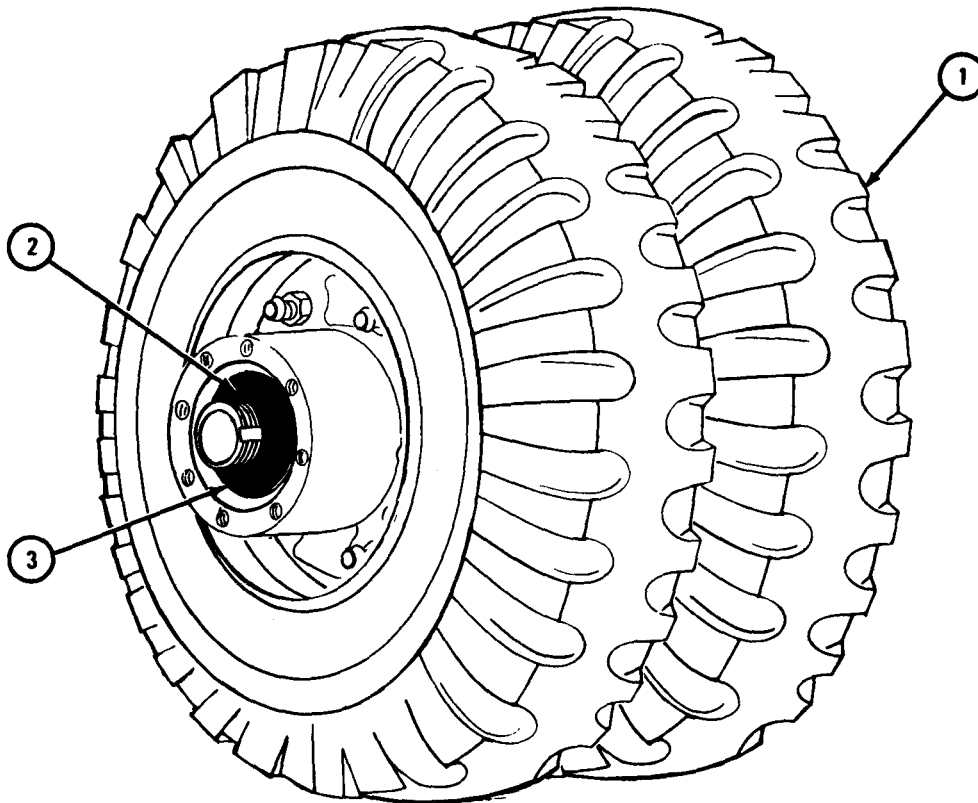

TA 047632

FRAME 4

1. Put lockwasher (1) on spindle (2) so that tab on lockwasher fits in keyway in spindle.
2. Using wheel bearing nut wrench with torque wrench, screw on locknut (3) and tighten it to 50 pound-feet.
3. Using hammer and punch, bend down tabs on lockwasher (1) as shown.

GO TO FRAME 5

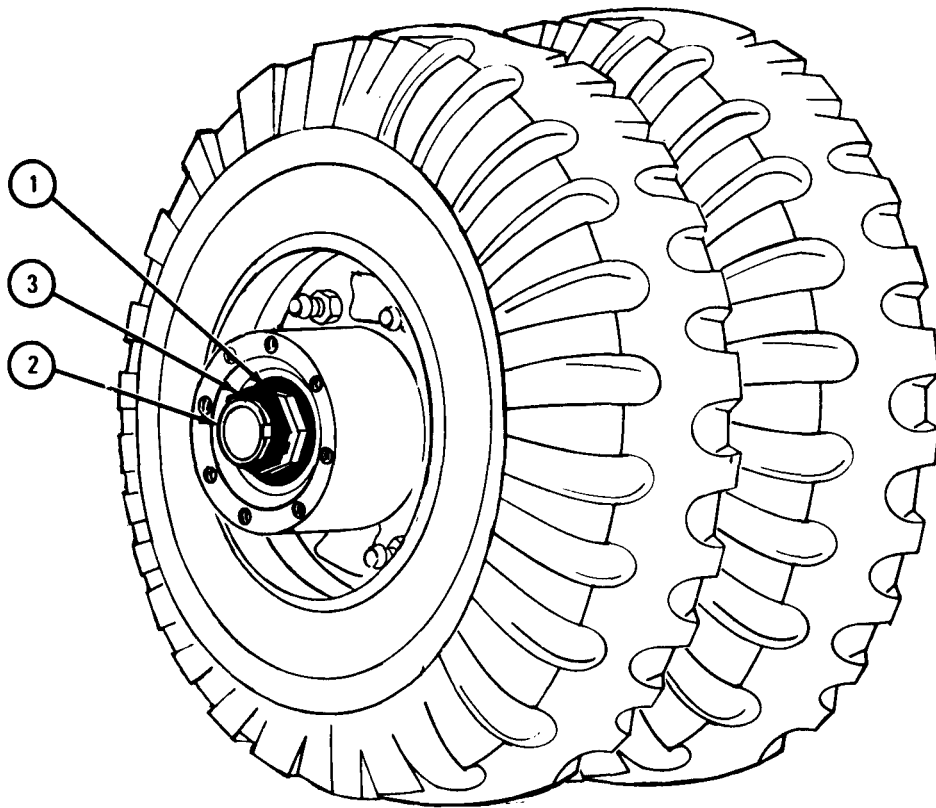

TA 047634

FRAME 5

1. Put gasket (1) on axle shaft assembly (2). Put axle shaft assembly into hub (3).
2. Using 3/4-inch wrench, screw in eight capscrews and eight lockwashers (4).
3. Lower rear wheels onto ground. Refer to Part 1, para 11-3.
4. Using torque wrench with 3/4-inch socket wrench, tighten eight capscrews (4) to 85 to 95 pound-feet.

END OF TASK

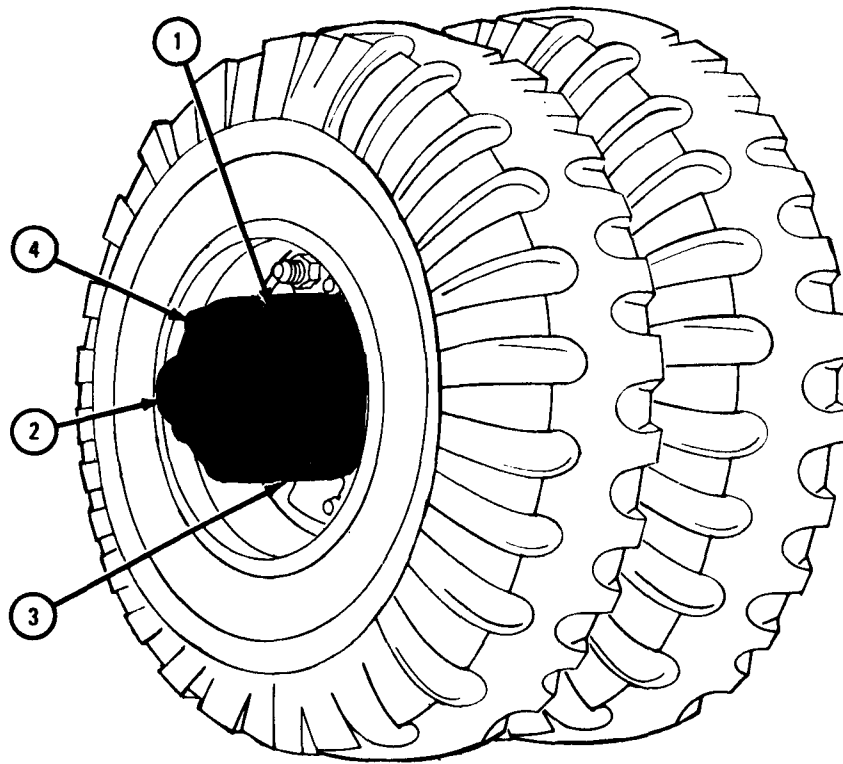

TA 047635

14-9. REAR HUB AND BRAKE DRUM ASSEMBLY REMOVAL AND REPLACEMENT.

TOOLS: 3/4-inch wrench
 Wheel bearing nut wrench, pn 7076869
 Torque wrench, 150 pound-feet capacity
 1/4-inch pin punch
 Portable bearing lubricator
 3/4-inch socket wrench
 10-inch socket handle
 8-ounce ballpeen hammer
 Brass drift pin punch
 Hand grease gun

SUPPLIES: Drive flange gasket
 Artillery and automotive grease, type GAA, MIL-G-10924

PERSONNEL: Two

EQUIPMENT CONDITION: Truck parked on level ground, engine off, handbrake set.

- a. Preliminary Procedure. Remove rear wheel. Refer to TM 9-2320-209-10.
- b. Removal.

FRAME 1

1. Using 3/4-inch wrench, unscrew and take off eight capscrews and eight lockwashers (1).
 2. Take out axle shaft assembly (2) and gasket (3). Throw away gasket (3).
- GO TO FRAME 2

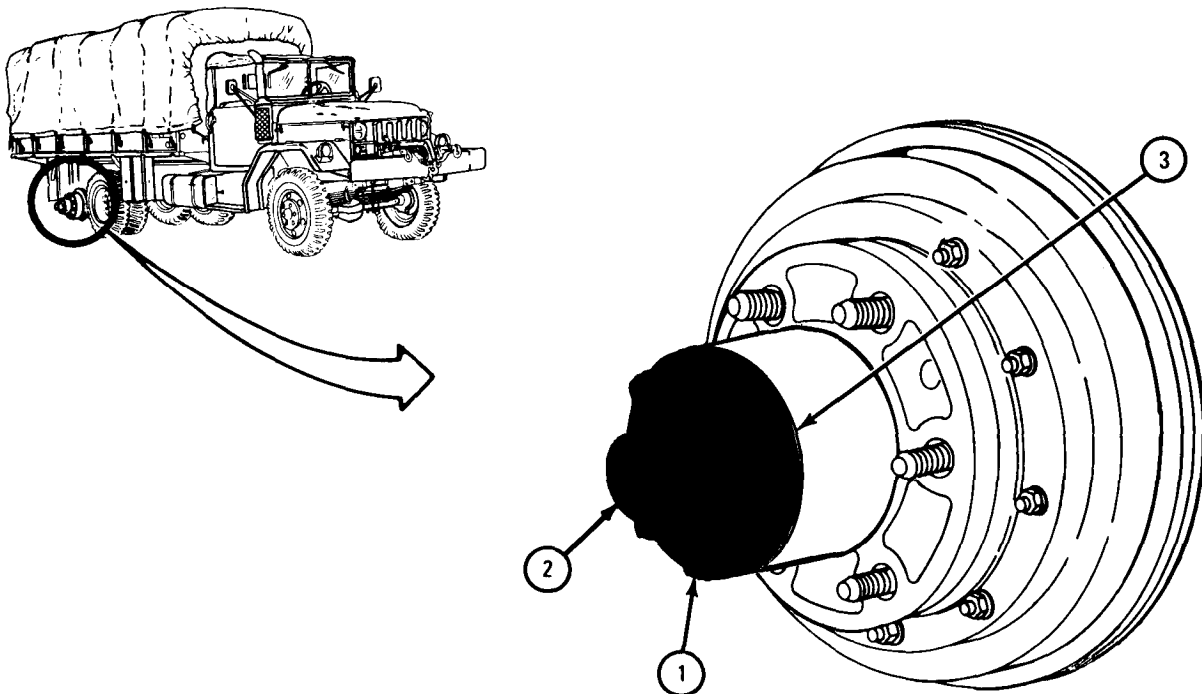

TA 047624

FRAME 2

1. Using hammer and punch, bend up tabs on adjusting nut lockwasher (1) so that locknut (2) can be turned.
2. Using wheel bearing nut wrench, unscrew and take off locknut (2). Take off adjusting nut lockwasher (1).

GO TO FRAME 3

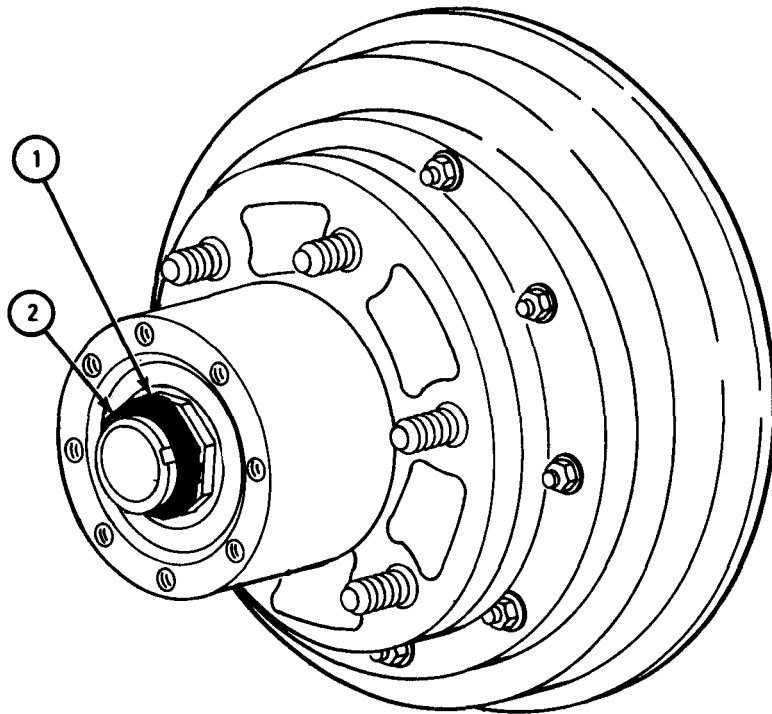

TA 047625

FRAME 3

1. Using wheel bearing nut wrench and socket handle, unscrew and take off adjusting nut (1).

GO TO FRAME 4

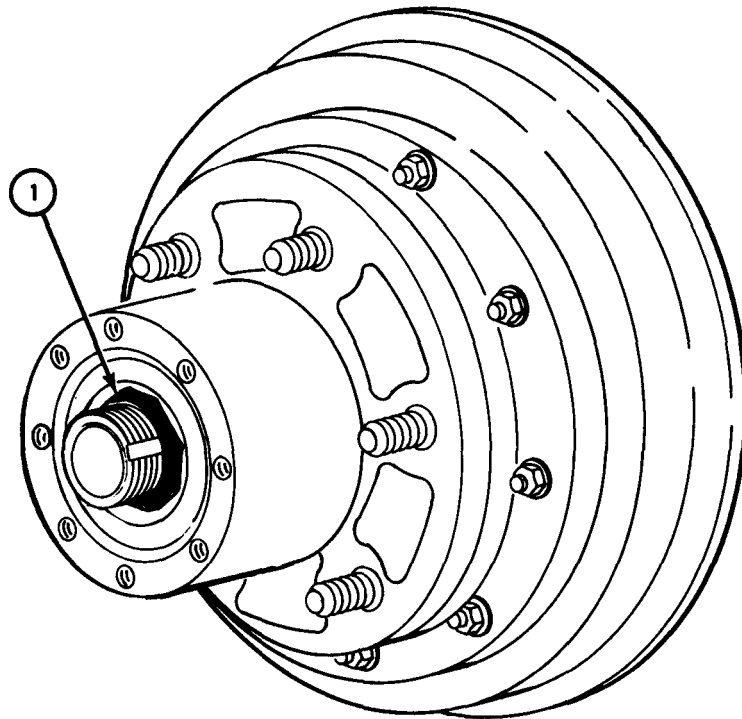

TA 047626

FRAME 4

1. Take off outer seal (1).
2. Take off outer bearing cone (2).

Soldiers 3. Take off hub and brake drum assembly (3).
A and B

END OF TASK

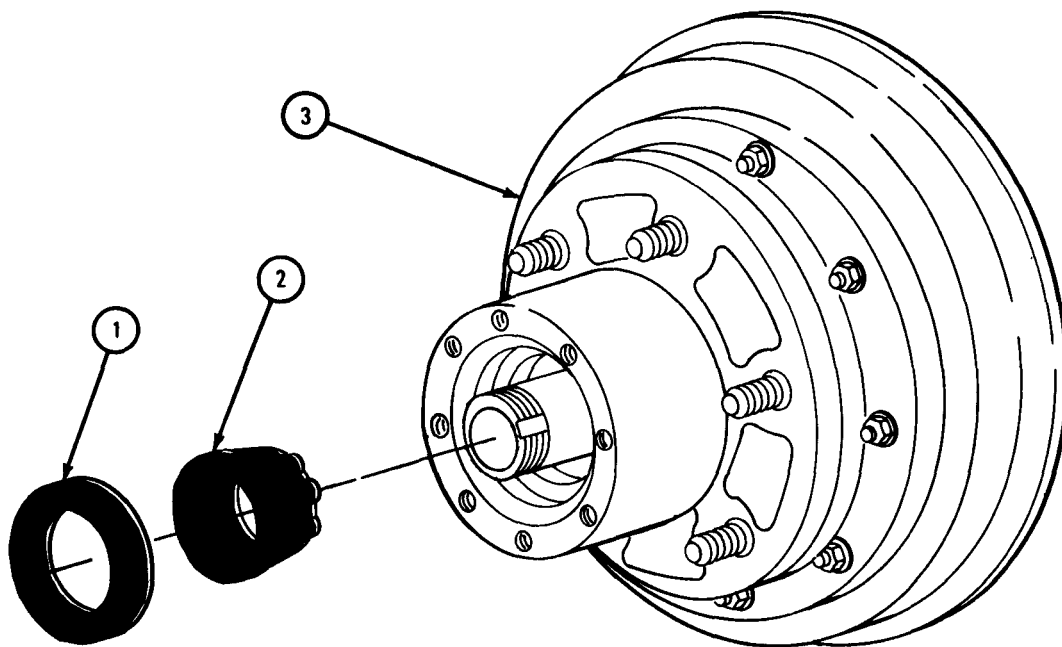

TA 047627

c. Replacement.

FRAME 1

Soldiers 1. Put hub and drum assembly (1) on spindle (2).
A and B
GO TO FRAME 2

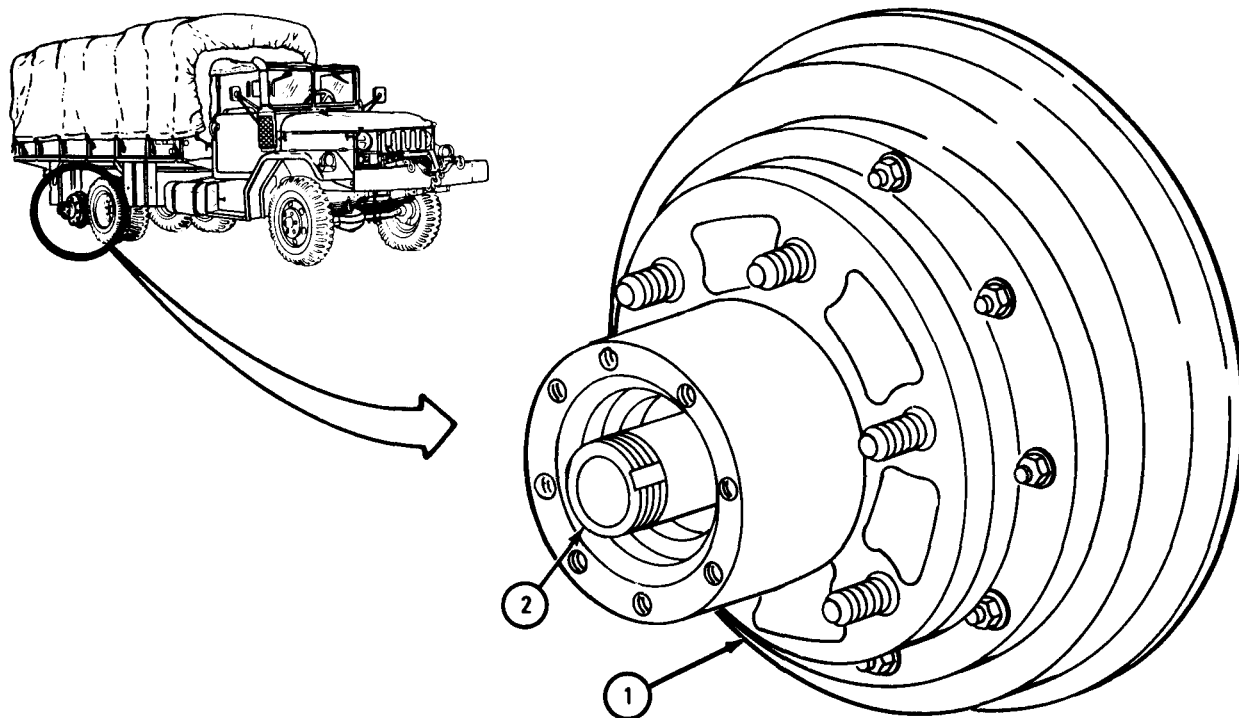

TA 047630

FRAME 2

1. Clean, inspect, and lubricate wheel bearing cone (1). Refer to para 14-11.

CAUTION

Do not slide seal lip over threaded end of spindle to prevent damage to seal.

2. Put outer wheel bearing cone (1) and outer grease seal (2) in hub and drum assembly (3).
3. Using wheel bearing nut wrench, screw on adjusting nut (4).

GO TO FRAME 3

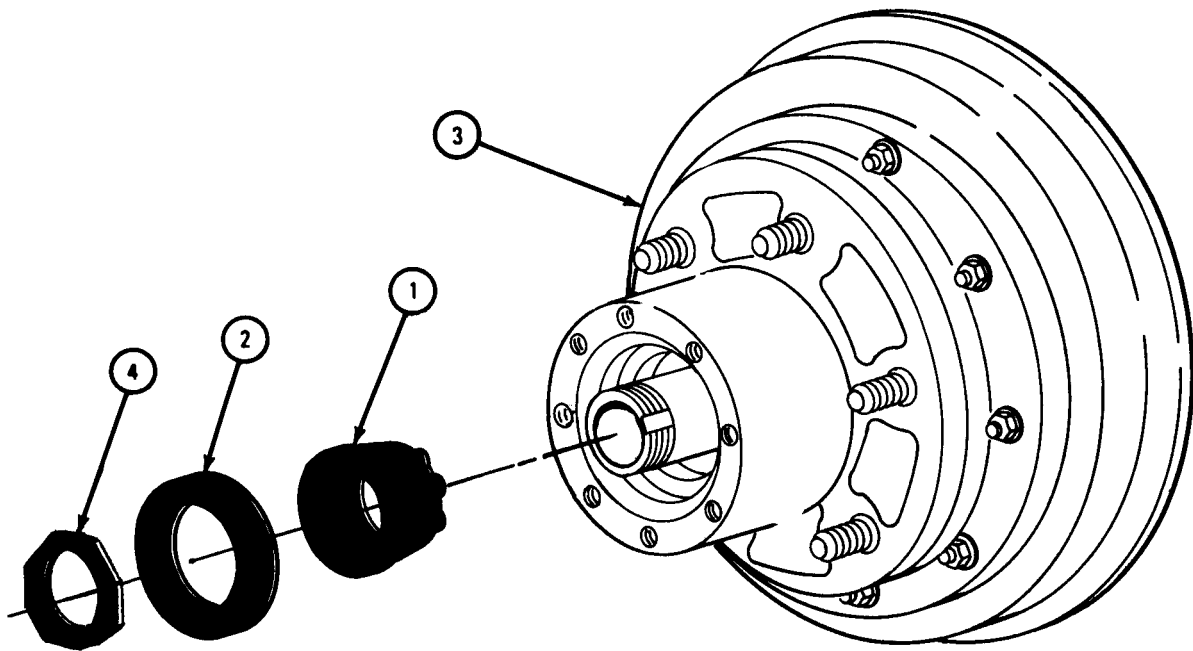

TA 047631

FRAME 3

1. Check brake adjustment. Refer to para 13-9.
2. Replace rear wheels, but do not jack down truck. Refer to TM 9-2320-209-10.
3. While turning wheels (1) and using wheel bearing nut wrench, tighten adjusting nut (2) until wheels bind.
4. Using wheel bearing nut wrench, back off adjusting nut (2) 1/8 turn.
5. Put one hand on bottom and one hand on top of wheels (1). Push with one hand and pull with other hand. If wheel bearing (3) is adjusted correctly, wheel should have very little wobble.

GO TO FRAME 4

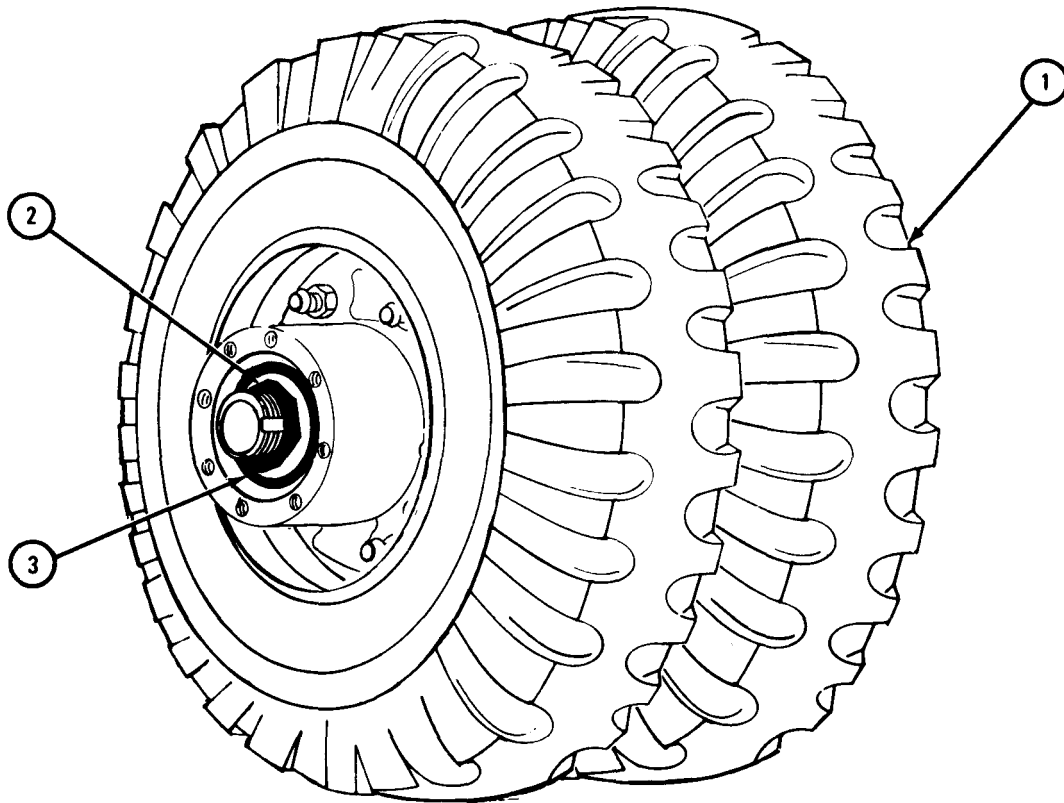

TA 101739

FRAME 4

1. Put lockwasher (1) on spindle (2) so that tab on washer fits in keyway in spindle.
 2. Using wheel bearing nut wrench, screw on and tighten locknut (3).
 3. Using hammer and punch, bend down tabs on lockwasher (1) as shown over locknut (3).
- GO TO FRAME 5

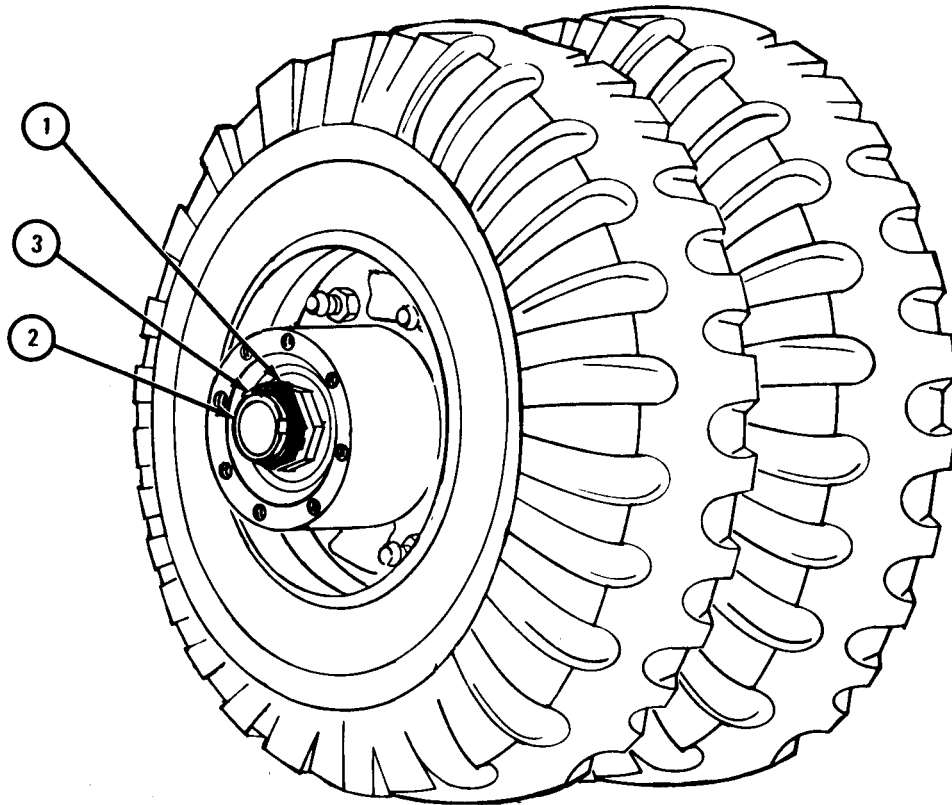

TA 101740

FRAME 5

1. Put gasket (1) on axle shaft assembly (2). Put axle shaft assembly into hub (3).
2. Using 3/4-inch wrench, screw in eight capscrews and eight lockwashers (4).
3. Using jack, lower rear wheels onto ground. Refer to TM 9-2320-209-10.
4. Using torque wrench with 3/4-inch socket wrench, tighten eight capscrews (4) to 85 to 95 pound-feet.

END OF TASK

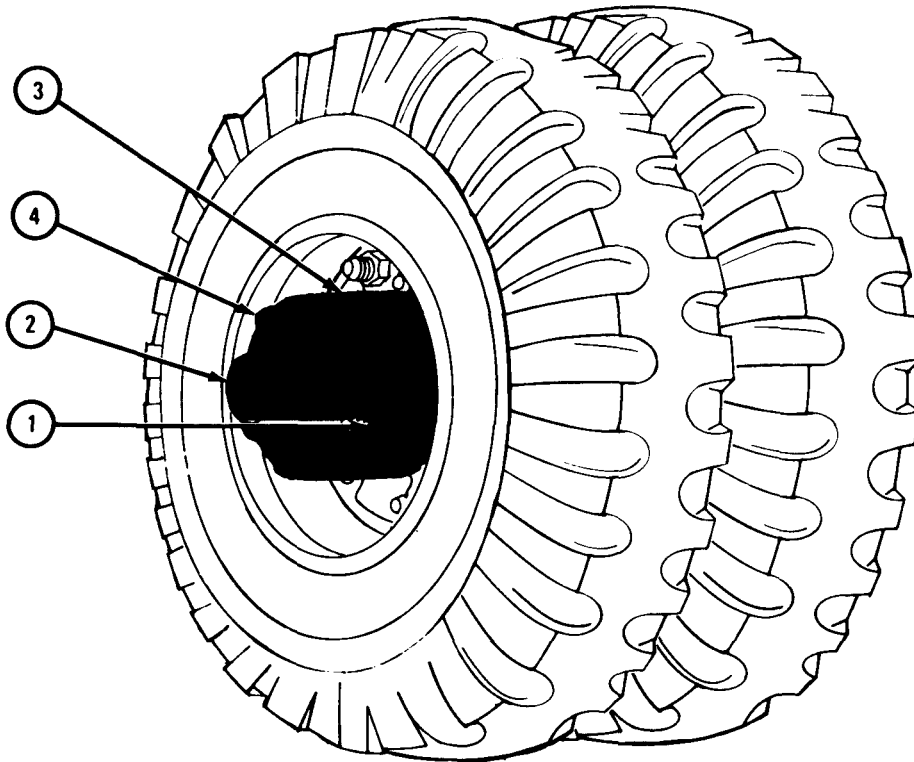

TA 101741

14-10. REAR INNER AND OUTER WHEEL BEARINGS AND SEALS REMOVAL AND REPLACEMENT.

TOOLS: Oil seal replacer, pn c-10937827
Medium ballpeen hammer
3/4 x 10-inch brass drift

SUPPLIES: Artillery and automotive grease, type GAA, MIL-G-10924
Solvent, dry cleaning, type II (SD-2), Fed. Spec P-D-680
Rear wheel bearing inner seal
Clean rags

PERSONNEL: One

EQUIPMENT CONDITION: Truck parked, engine off, handbrake set.

- a. Preliminary Procedure. Remove rear hub and drum assembly. Refer to para 14-9.
- b. Removal.

NOTE

Outer wheel bearing cone and seal are taken out during removal of rear wheels and drum assembly.

FRAME 1

1. Using puller, pull bearing (1) off of wheel hub spindle (2).
 2. Using puller, pull off seal (3). Throw away seal.
- GO TO FRAME 2

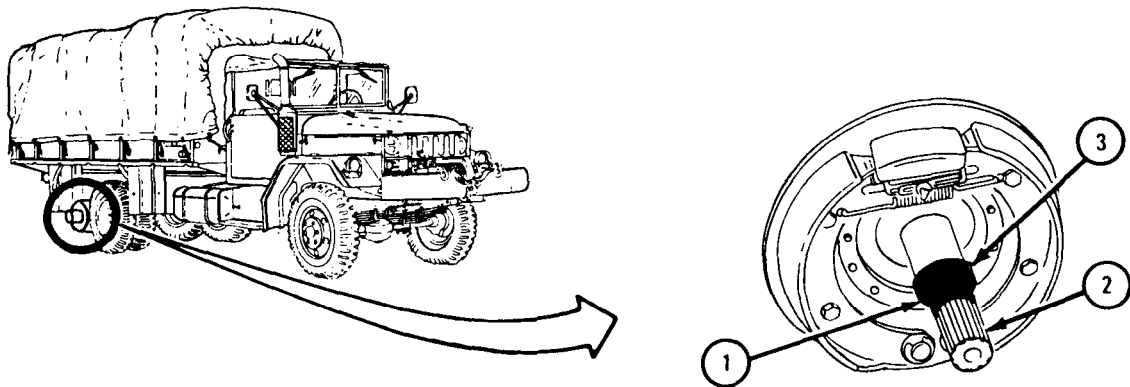

TA 101643

FRAME 2

1. Working through rear of hub and drum assembly (1) using wheel bearing cup remover and replacer and hammer, tap out outer wheel bearing cup (2).
2. Turn over hub and drum assembly (1).

GO TO FRAME 3

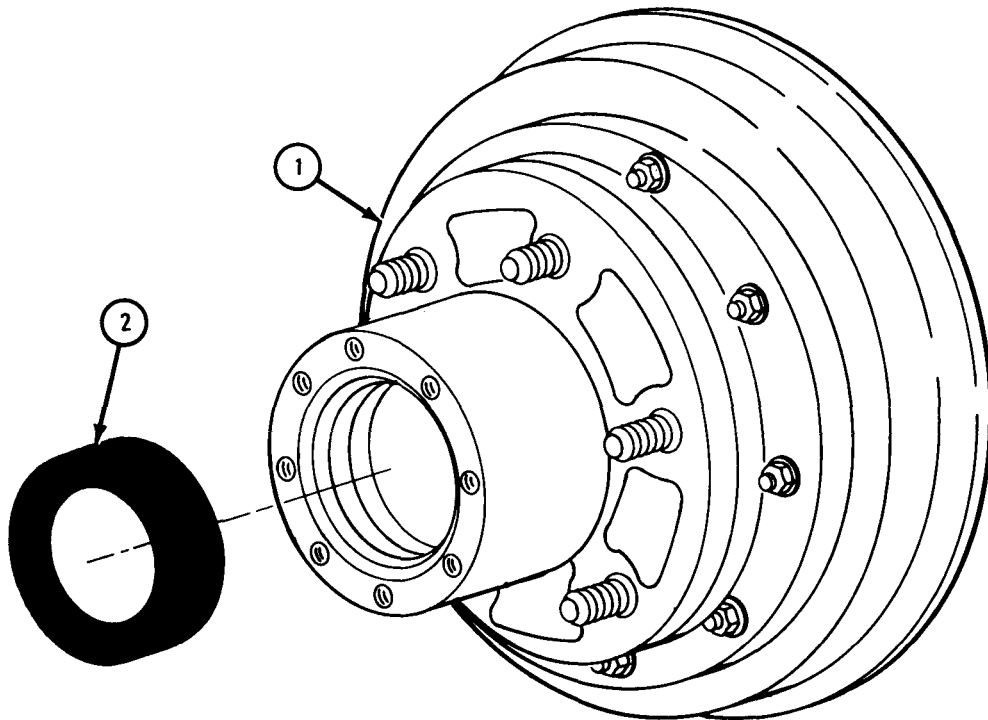

TA 082208

FRAME 3

1. Working through front of hub and drum assembly (1), using wheel bearing cup remover and replacer and hammer, tap out inner wheel bearing cup (2).

END OF TASK

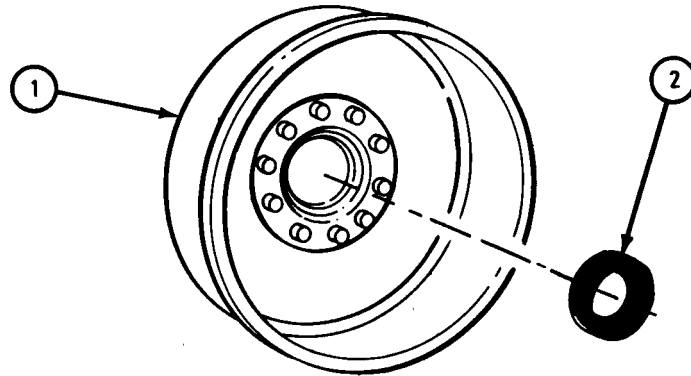

TA 082209

c. Cleaning.

NOTE

This task is for both inner and outer wheel bearing cones.

FRAME 1

WARNING

Dry cleaning solvent is flammable. Do not use near an open flame. Keep a fire extinguisher nearby when solvent is used. Use only in well-ventilated places. Failure to do this may result in injury to personnel and damage to equipment.

NOTE

All old lubricant must be taken off bearings during cleaning. Soak bearing as long as needed to take off all old lubricant.

1. Soak bearing cone (1) in solvent.
2. Rinse bearing cone (1) in clean solvent.

WARNING

Do not dry bearing with compressed air. Spinning bearings may explode and cause serious injury to personnel.

3. Let bearing cone (1) air dry.
4. Using clean rags, wipe all old grease from inside hub (2).

END OF TASK

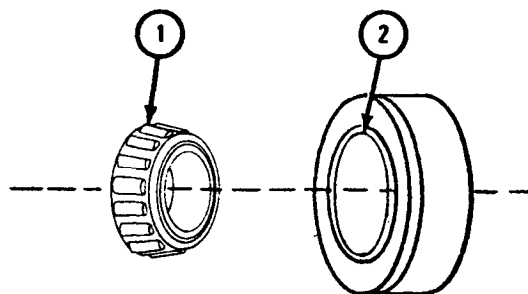

TA 050472

d. Inspection.

FRAME 1

NOTE

Inner and outer wheel bearing cups are inside of hub. If wheel bearing cone (1) or cup (4) needs replacing, do wheel bearing cones and seals removal and replacement. Refer to para 14-10b for removal. Refer to 14-10f for replacement.

1. Place drop light behind bearing assembly.
2. Hold wheel bearing cone (1) and turn inner race (2) slowly.
3. Check that bearing rollers (3) and wheel bearing cone (1) have no cracks, flaking, pitting, or long or deep scratches.
4. Check that wheel bearing cone (1) has not overheated. Wheel bearing cone will turn blue where it has overheated.
5. Check that cups (4) have no dents or small depressions.

NOTE

If bearing rollers (3) are damaged, throw bearing cone (1) away and get a new one.

6. Check that bearing cups (4) and bearing rollers (3) are not splintered or chipped.
7. Throw away damaged parts and get new ones.

END OF TASK

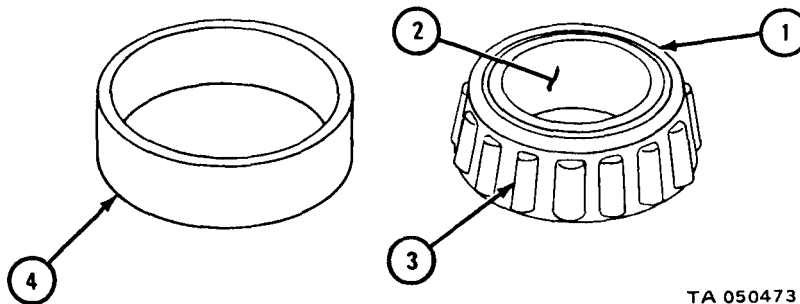

TA 050473

FRAME 1

1. Put wheel bearing cone (1) into portable bearing lubricator as shown.
2. Using hand grease gun, grease wheel bearing cone (1) until grease comes out of sides of bearing.

END OF TASK

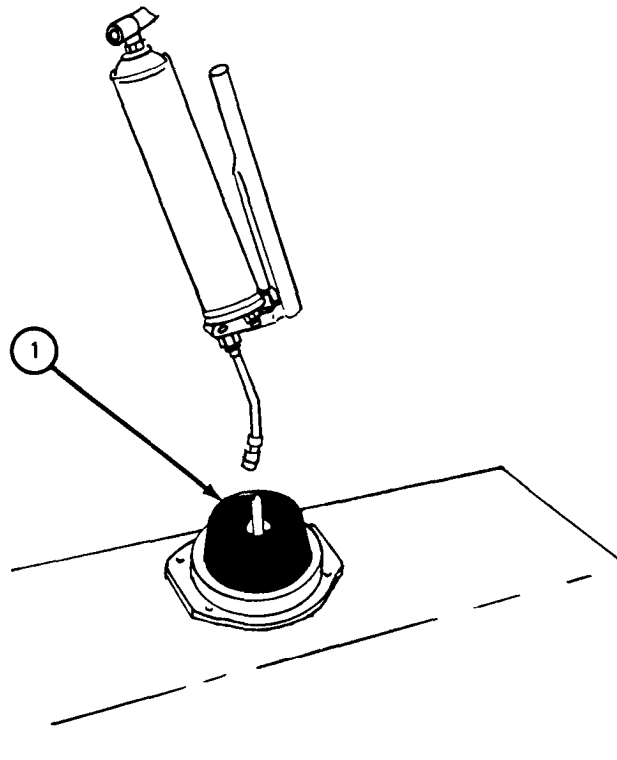

TA 082024

f. Replacement.

FRAME 1

1. Using wheel bearing cup remover and replacer and hammer, tap in inner wheel bearing cup (1) until it is seated inside hub (2).
 2. Turn over hub and drum assembly (3).
- GO TO FRAME 2

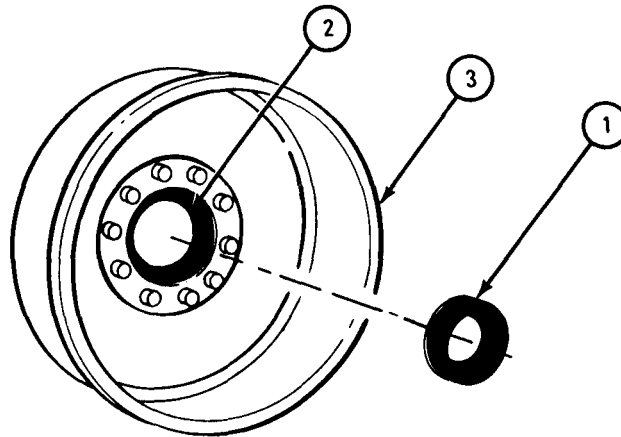

TA 088210

FRAME 2

1. Using wheel bearing cup remover and replacer and hammer, tap in outer wheel bearing cup (1) until it is seated inside hub (2).

2. Turn over hub and drum assembly (3).

GO TO FRAME 3

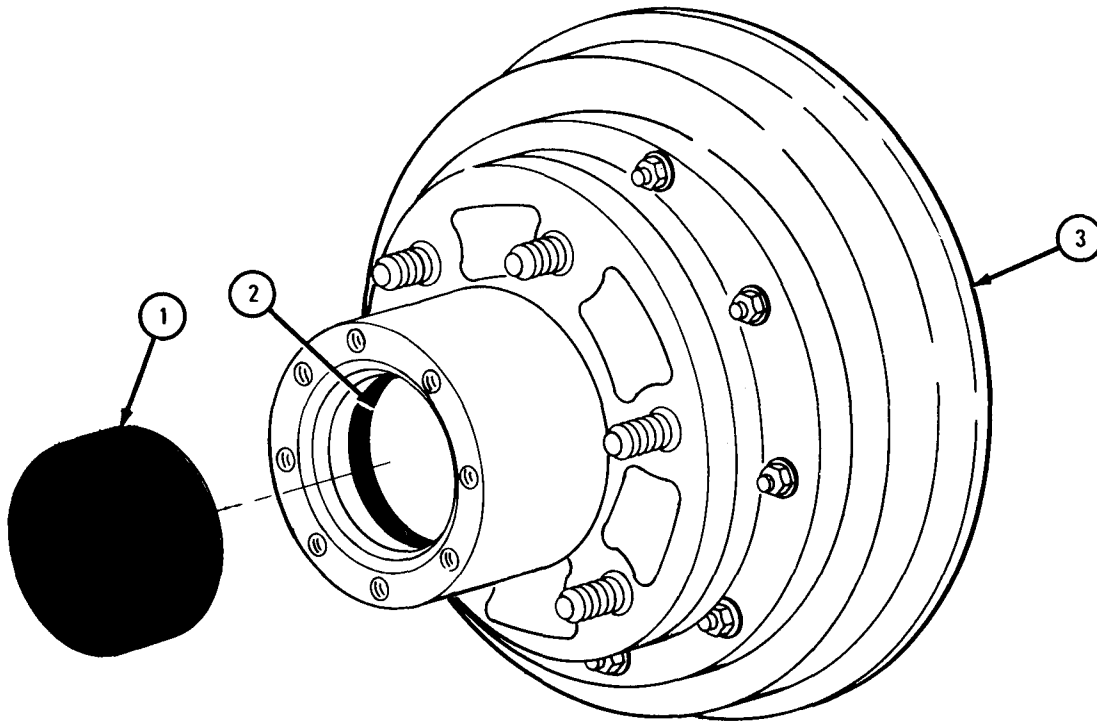

TA 082211

FRAME 3

1. Using hammer and brass drift, tap seal (1) into place on wheel hub spindle (2).

NOTE

Put back bearing (3) with tapered end facing away from wheel hub spindle (2).

2. Using hammer and brass drift, tap bearing (3) into place with tapered end away from wheel hub spindle (2).
3. Using clean rag, wipe all grease from seal (1).

NOTE

Follow-on Maintenance Action Required:

Replace rear hub and drum assembly. Refer to para 14-9.

END OF TASK

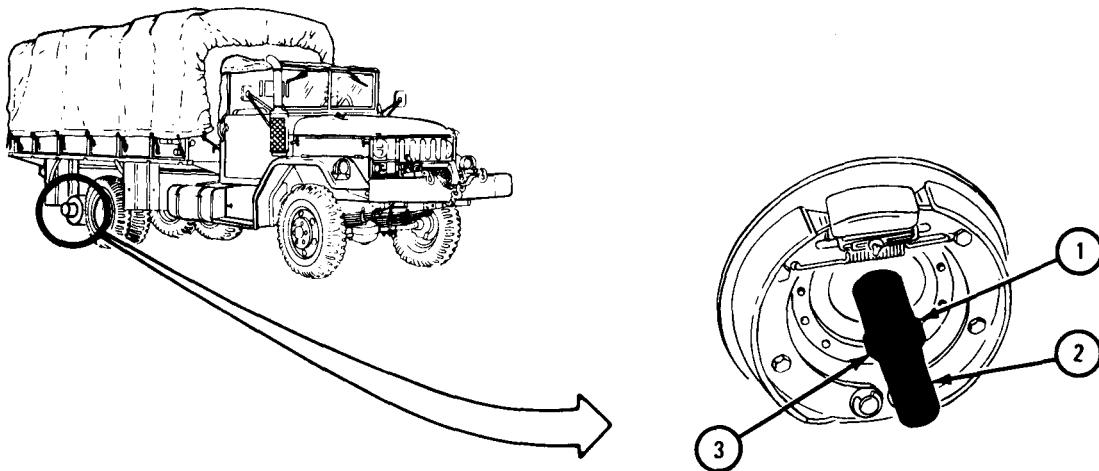

TA 101647

14-11. REAR WHEEL BEARING CONES AND SEALS REMOVAL AND REPLACEMENT FOR SERVICE.

TOOLS: Oil seal replacer, C10937827
3/4 x 10-inch brass drift

SUPPLIES: Artillery and automotive grease, type GAA, MIL-G-10924
Solvent, dry cleaning, type II (SD-2), Fed. Spec P-D-680
Clean rags
Rear wheel bearing inner seal

PERSONNEL: One

EQUIPMENT CONDITION: Truck parked on level ground, engine off, handbrake set.

- a. Preliminary Procedure. Remove rear wheels and brake drum assembly. Refer to para 14-8.
- b. Removal.

FRAME 1

NOTE

Outer wheel bearing cone and seal are taken out during removal of rear wheels and brake drum assembly.

1. Using puller, pull bearing (1) off wheel hub spindle (2).
2. Using hammer and brass drift, tap and slide off seal (3). Throw away seal.

END OF TASK

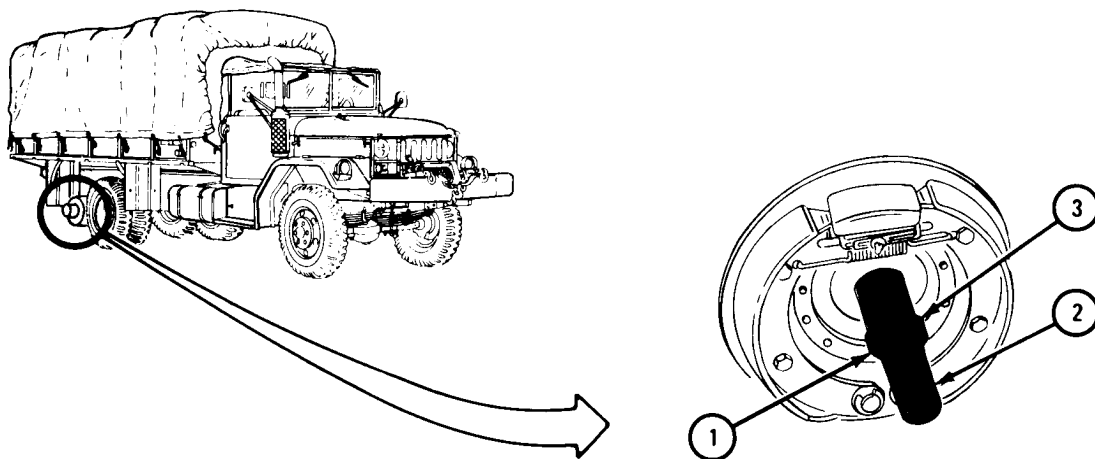

TA 101652

c. Cleaning.

NOTE

This task is for both inner and outer wheel bearing cones.

FRAME 1

WARNING

Dry cleaning solvent is flammable. Do not use near an open flame. Keep a fire extinguisher nearby when solvent is used. Use only in well-ventilated places. Failure to do this may result in injury to personnel and damage to equipment.

NOTE

All old lubricant must be taken off bearing during cleaning. Soak bearing as long as needed to take off all old lubricant.

1. Soak bearing cone (1) in solvent.
2. Rinse bearing cone (1) in clean solvent.

WARNING

Do not dry bearing with compressed air. Spinning bearings may explode and cause serious injury to personnel.

3. Let bearing cone (1) air dry.
4. Using clean rags, wipe all old grease from inside hub (2).

END OF TASK

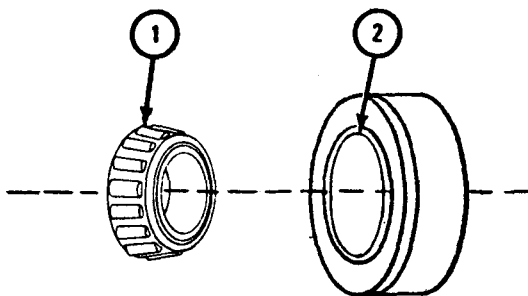

TA 050472

d. Inspection.

FRAME 1

NOTE

Inner and outer wheel bearing cups are inside of hub.
If wheel bearing cone (1) or cup (4) needs replacing,
do wheel bearing cones and seals removal and replace-
ment. Refer to para 14-11b for removal. Refer to
para 14-11f for replacement.

1. Place a light behind bearing assembly.
2. Hold wheel bearing cone (1) and turn inner race (2) slowly.

NOTE

If bearing rollers (3) are damaged throw away bearing cone
(1) and get a new one.

3. Check that bearing rollers (3) and wheel bearing cone (1) have no cracks, flaking, pitting or long or deep scratches.
4. Check that wheel bearing cone (1) has not overheated. Wheel bearing cone will turn blue where it has overheated.
5. Check that bearing cups (4) have no dents or small depressions.
6. Check that bearing cups (4) and bearing rollers (3) are not splintered or chipped.
7. Throw away damaged parts and get new ones.

END OF TASK

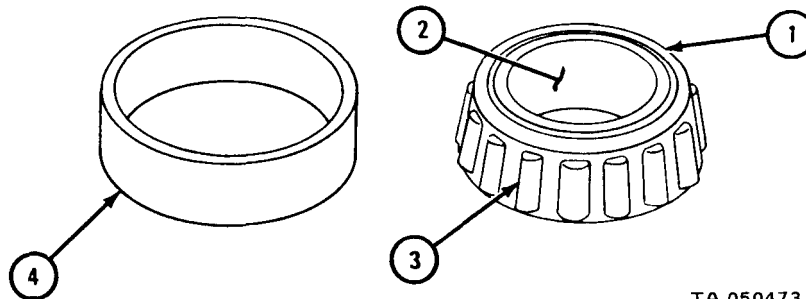

TA 050473

e. Lubrication.

FRAME 1

1. Put wheel bearing cone (1) into portable bearing lubricator as shown.
2. Using hand grease gun, grease wheel bearing cone (1) until grease comes out of sides of bearing.

END OF TASK

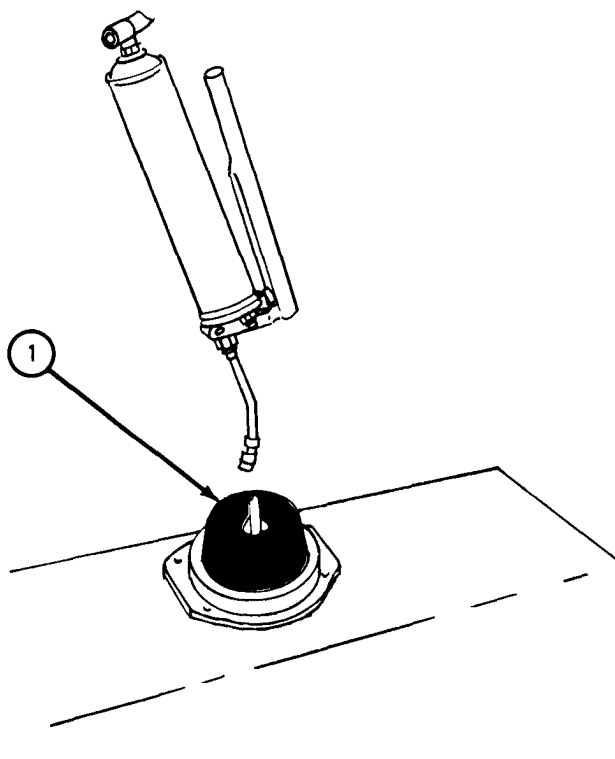

TA 082024

f. Replacement.**FRAME 1**

1. Using hammer and brass drift, tap seal (1) into place on spindle (2).
2. Using hammer and brass drift, tap bearing (3) into place with tapered end facing as shown.
3. Using clean rag, wipe all grease from seal (1).

NOTE

Follow-on Maintenance Action Required:

Replace rear wheels and brake drum assembly. Refer to para 14-8.

END OF TASK

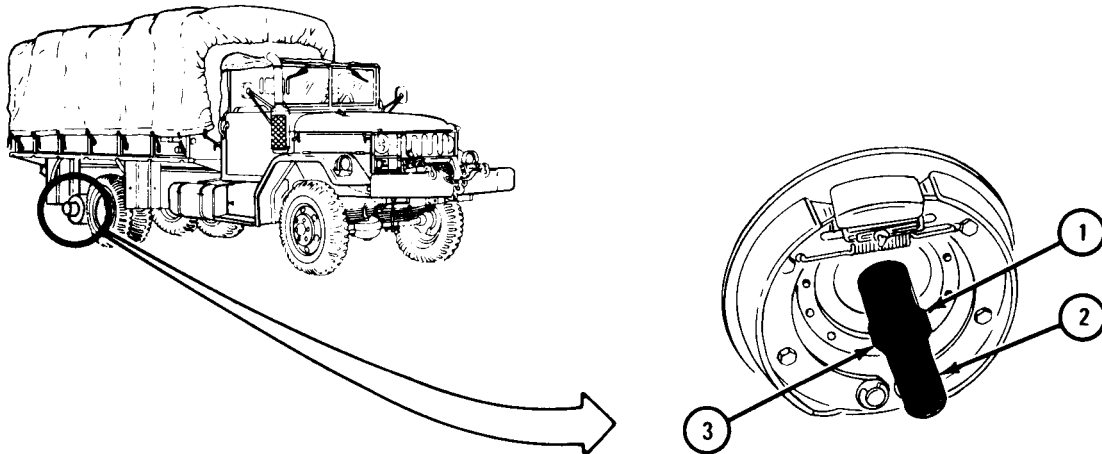

TA 101656

Section IV. TIRES

14-12. TIRE AND TUBE REMOVAL AND REPLACEMENT.

TOOLS: Curve spoon tire iron
Locking ring tire iron
Tire demounter
Mallet
Air supply oil hose and air chuck

SUPPLIES: Wood blocks (3)

PERSONNEL: Two

EQUIPMENT CONDITION: Truck parked, engine off, handbrake set.

a. Preliminary Procedure. Remove wheel from truck. Refer to TM 9-2320-209-10.

b. Removal.

FRAME 1

1. Unscrew tire valve cap (1) from valve stem (2).
2. Using tire valve cap (1) as tool, unscrew valve core (3) out of valve stem (2).
Air will come out of tire.

GO TO FRAME 2

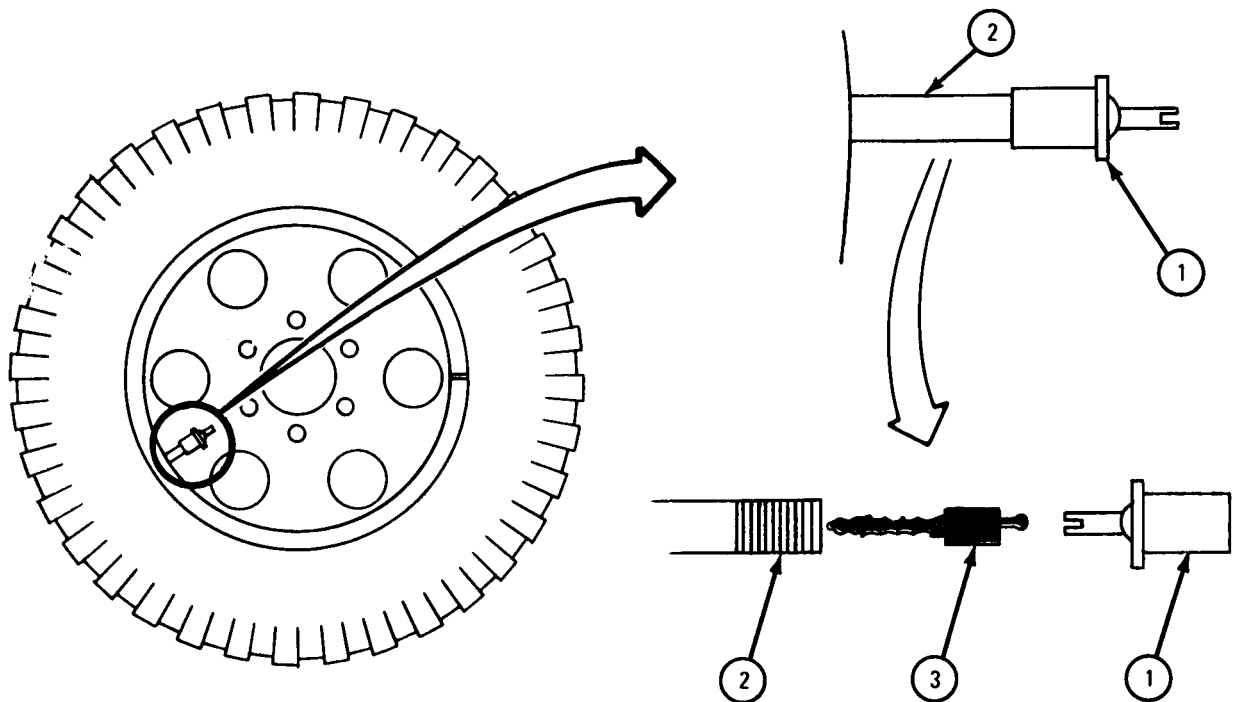

TA 046302

FRAME 2

WARNING

Do not work on tire until all the air is out of it. Stand clear of retaining ring to avoid injury if the ring should fly off.

NOTE

Put a soap and water solution on the tire bead to help in the removal of tire from the rim.

Soldiers 1. When all of the air is out of tire (1), put tire and rim (2) on A and B demounter base (3).

GO TO FRAME 3

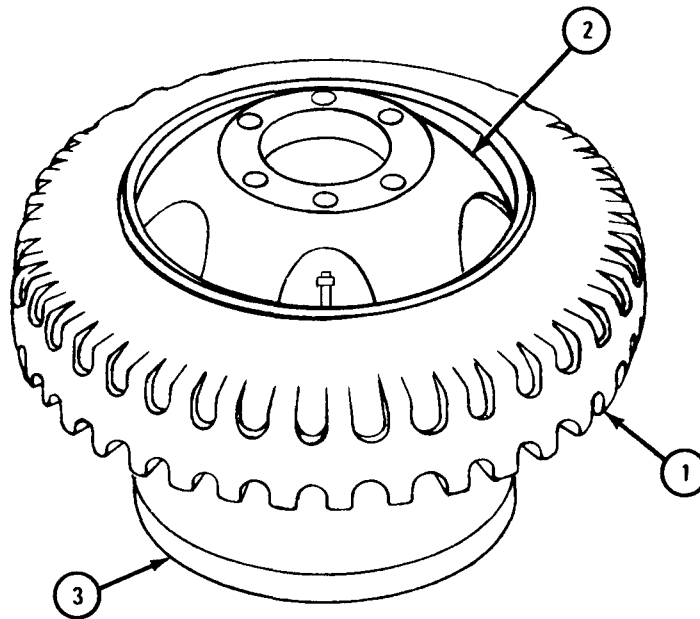

TA 080854

FRAME 3

1. Put demounter (1) in place on tire and rim assembly (2).
2. Slide four bead breaker feet (3) into position on cross arms (4) and seat bead breaker feet on tire bead (5) against retaining ring (6).
3. Screw in handle (7) until tire bead (5) breaks away from rim (8).
4. Unscrew handle (7) and take demounter (1) off tire and rim assembly (2).

Soldiers A and B 5. Turn tire and rim assembly (2) over on demounter base (9). Do steps 1 through 4 again on other side of tire and rim assembly.

Soldiers A and B 6. Take tire and rim assembly (2) off demounter (1) and demounter base (9).

GO TO FRAME 4

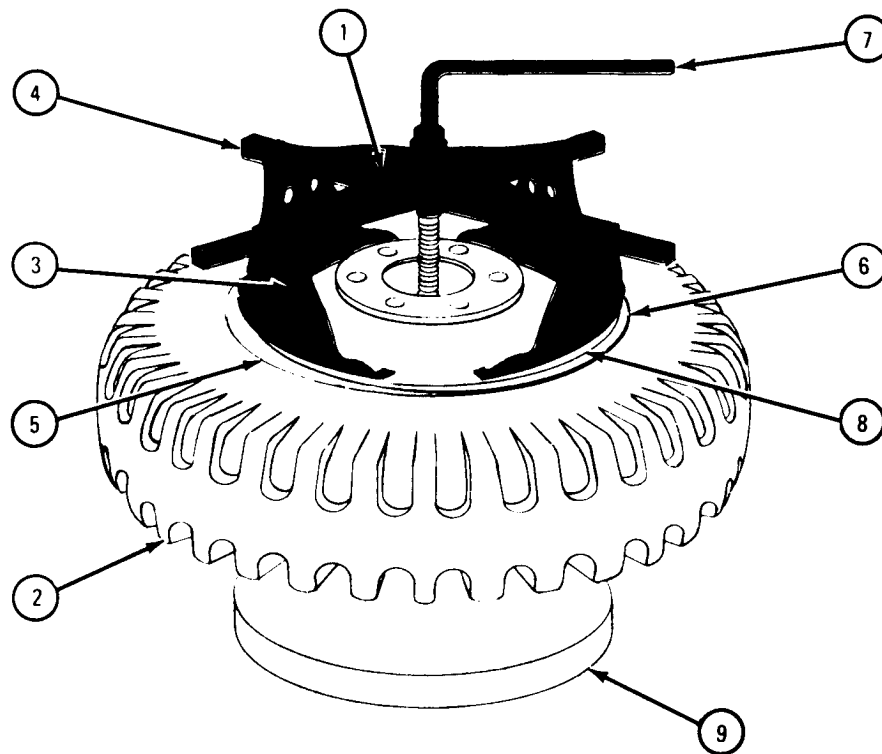

TA 080855

FRAME 4

1. Put tire (1) and rim (2) on a hard flat surface.
2. Using foot, push tire (1) down from retaining ring(3) at joining ends (4).
3. Using tire irons, put one between joining ends (4) and the other tire iron into notch (5).
4. Using both tire irons, pry retaining ring (3) open and out of rim (2) by sliding one tire iron after the other as shown.

GO TO FRAME 5

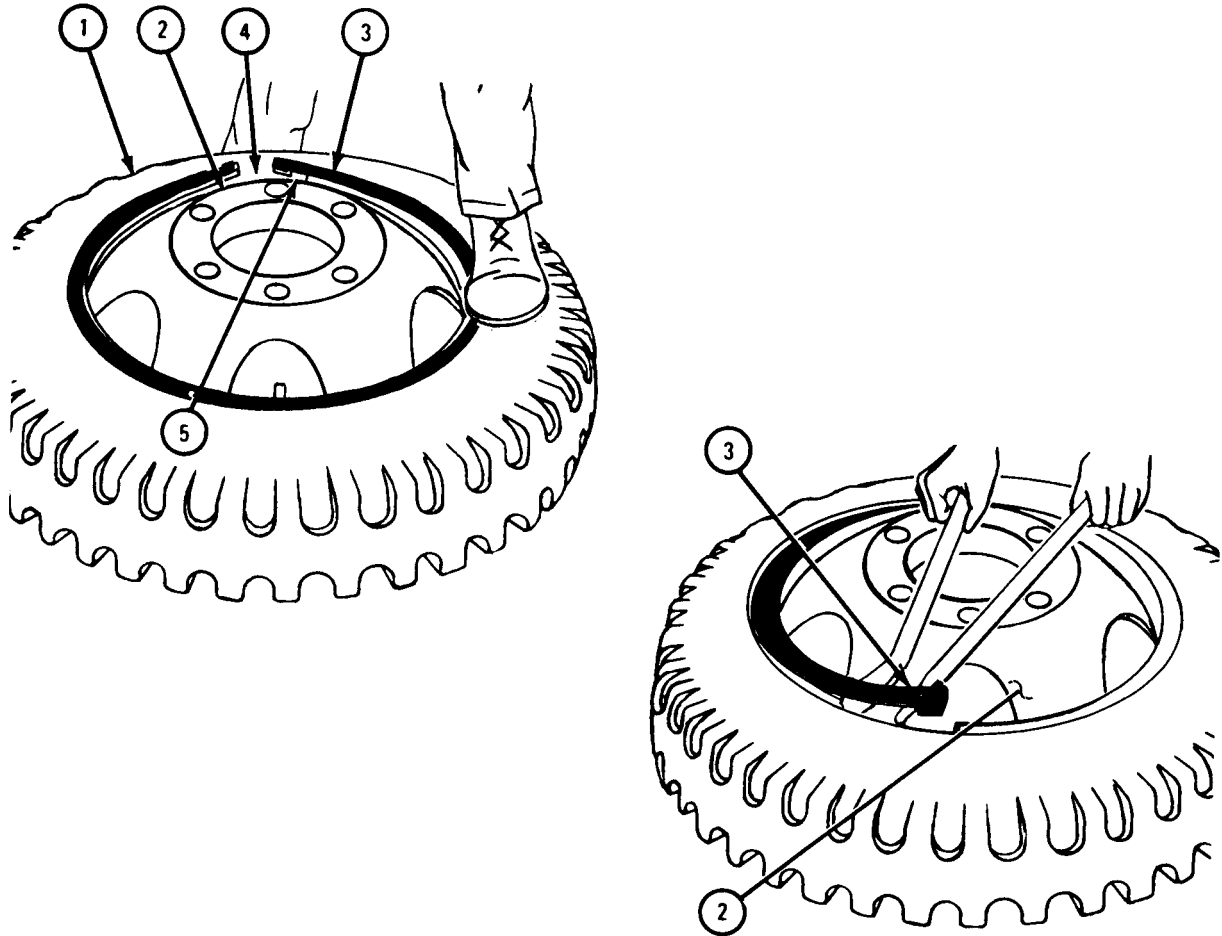

TA 080856

FRAME 5

1. Push valve stem (1) through rim (2) so it stays inside tire (3).
2. Put tire (3) on wood blocks. Using foot, push rim (2) down and out of tire.
3. Lift tire (3) off blocks and rim (2).
4. Take tire liner (4) and tube (5) out of tire (3).

END OF TASK

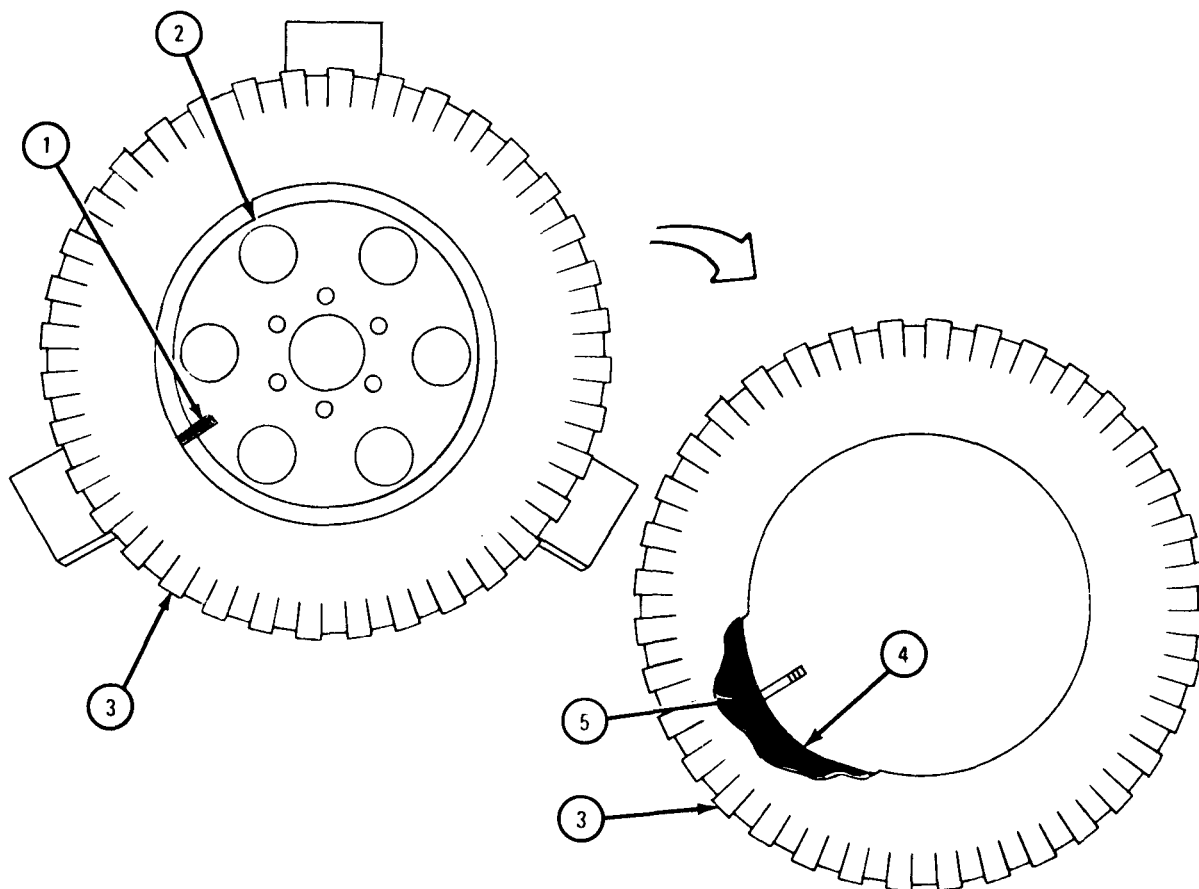

TA 080857

c. Replacement.**FRAME 1**

1. Using valve cap (1) as tool, screw valve core (2) into valve stem (3).
2. Put tube (4) into tire (5).
3. Put just enough air in tube (4) so tube holds shape. Refer to TM 9-2320-209-10 for tire inflation procedures.
4. Put tire liner (6) over valve stem (3) and into tire (5). Make sure tube (4) and tire liner are straight and not pinched.

GO TO FRAME 2

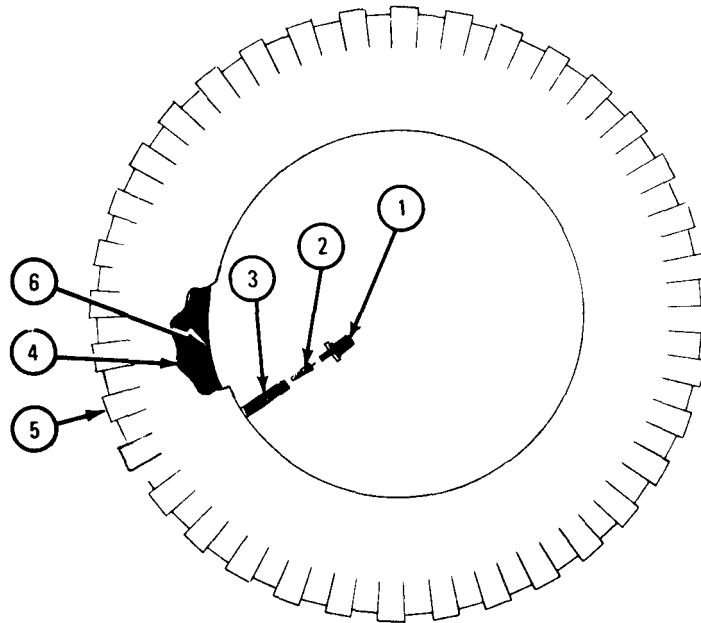

TA 080858

FRAME 2

1. Put tire (1) onto rim (2) so that valve stem (3) will point to the high part of the rim. Valve stem must line up with hole in rim.
2. Put valve stem (3) through hole in rim (2).
3. Seat tire (1) firmly onto rim (2).

GO TO FRAME 3

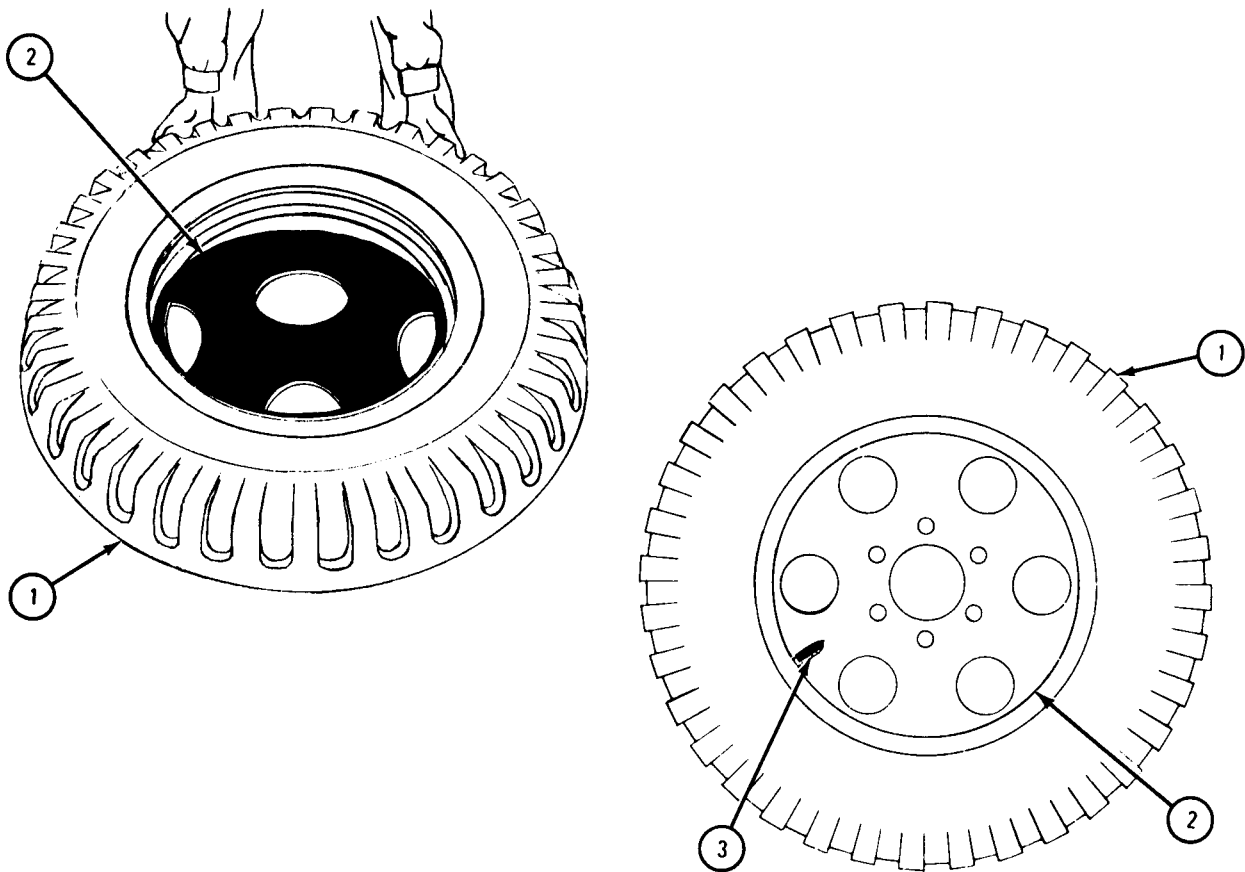

TA 080859

FRAME 3

1. Put end (1) of retaining ring (2) into rim groove (3) of rim (4). Check that the end is caught in the rim groove.
2. Using locking ring tire iron, put it in slot (5) in retaining ring (2). Pry iron toward outside of rim (4) forcing retaining ring into rim groove (3).
3. Using foot, walk retaining ring (2) into rim groove (3) until it is seated fully all the way around rim (4).
4. Using mallet, hammer all the way around on retaining ring (2) to make sure that it is fully caught in rim groove (3).

WARNING

Be careful when inflating tire. Remounted tires should always be inflated in a safety cage. If a safety cage is not available, turn tire and rim over with outer hub side down.

5. Put air in tire. Refer to TM 9-2320-209-10 and TM 9-2610-200-20. Screw on valve cap (6) after inflating tire.

NOTE

Follow-on Maintenance Action Required:

Replace wheel on truck. Refer to TM 9-2320-209-10.

END OF TASK

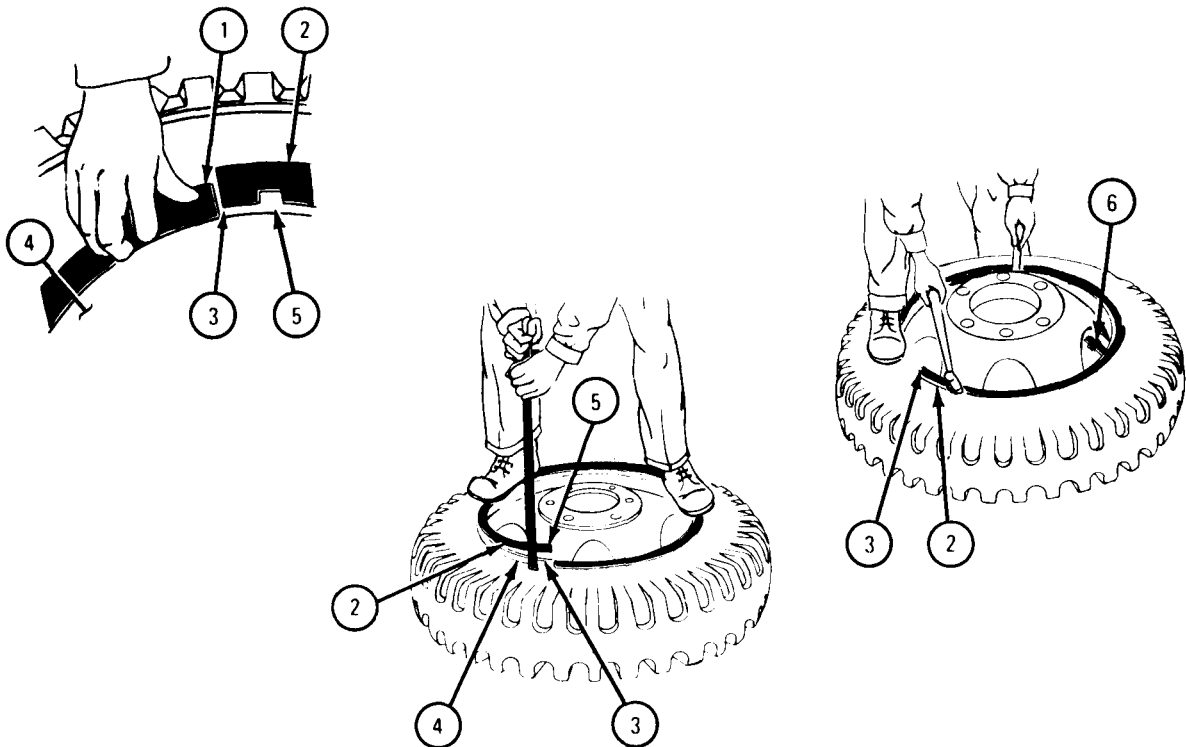

TA 080860

CHAPTER 15

STEERING SYSTEM GROUP MAINTENANCE

Section I. SCOPE

15-1. EQUIPMENT ITEMS COVERED. This chapter gives equipment maintenance procedures for the mechanical steering gear assembly for which there are authorized corrective maintenance tasks at the organizational maintenance level.

15-2. EQUIPMENT ITEMS NOT COVERED. All equipment items for which corrective maintenance is authorized at the organizational maintenance level are covered in this chapter.

Section II. MECHANICAL STEERING GEAR ASSEMBLY

15-3. FRONT WHEEL ALINEMENT.

TOOLS: Toe-in gage
15/16-inch wrench
Pipe wrench

SUPPLIES: None

PERSONNEL: Two

EQUIPMENT CONDITION: Truck parked on smooth level ground, wheels in straight ahead position, engine off, handbrake set.

a. Preliminary Procedures.

- (1) Inflate front tires to correct pressure. Refer to TM 9-2320-209-10.
- (2) Check wheel bearing adjustment. Refer to para 14-3.

b. Toe-in Check and Adjustment.

FRAME 1

1. Place toe-in gage (1) between front wheels, as far in front of axle (2) as possible.
2. Move toe-in gage (1) so that chains (3) just touch the ground and scale is toward rear of truck.

GO TO FRAME 2

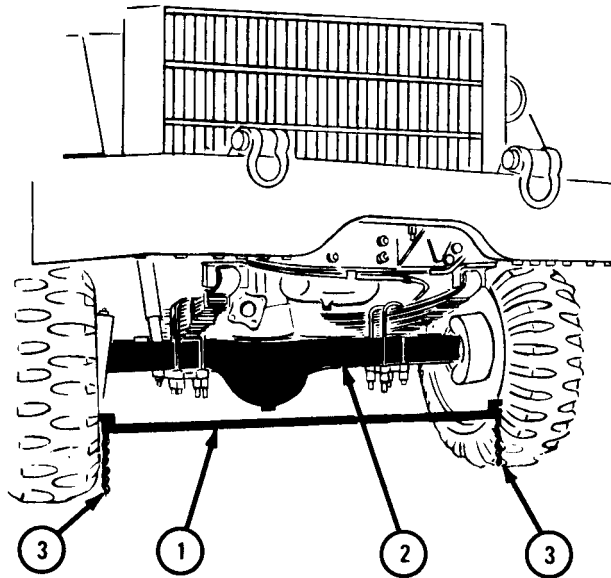

TA 047655

FRAME 2

1. Move scale (1) so that pointer (2) reads zero.

GO TO FRAME 3

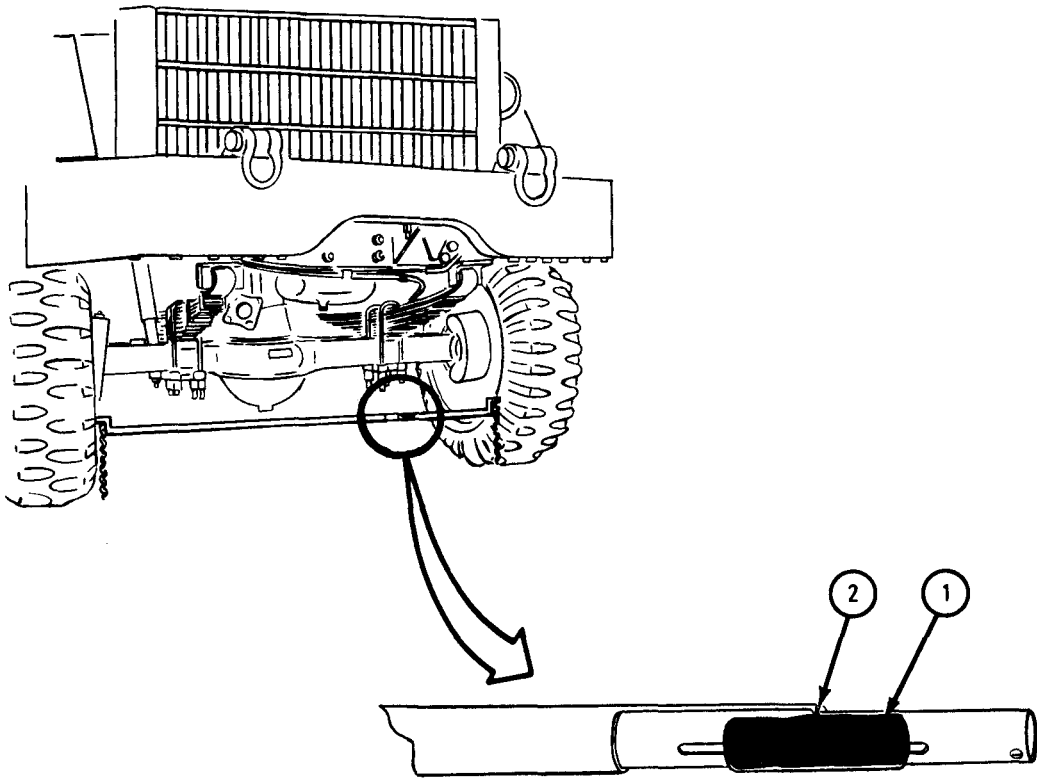

TA 047656

FRAME 3

- Soldier A 1. Start engine. Refer to TM 9-2320-209-10.
2. With toe-in gage (1) in place, move truck forward until soldier B tells you to stop.
- Soldier B 3. Tell soldier A to stop when the toe-in gage (1) is in back of axle (2) and chains (3) just touch the ground.
- Soldier A 4. Stop engine. Refer to TM 9-2320-209-10.
- GO TO FRAME 4

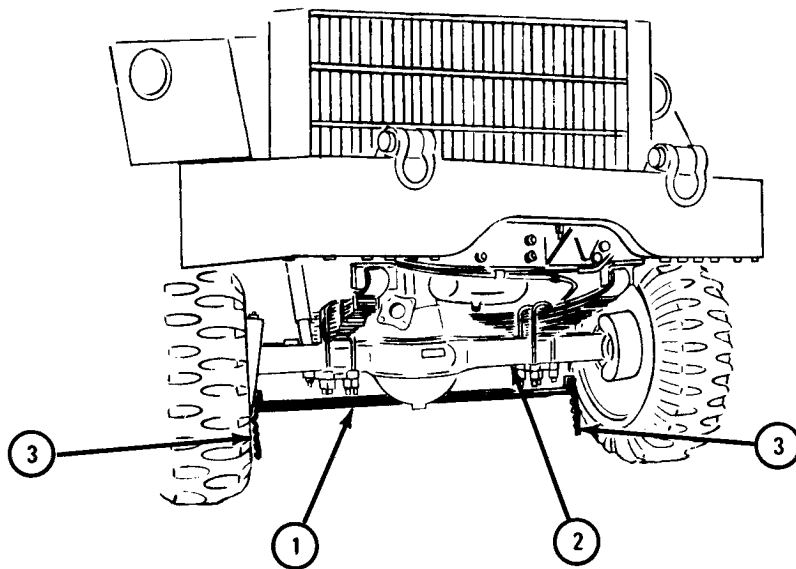

TA 047657

FRAME 4

1. Read position of pointer (1) on scale (2). Pointer should read $-1/16$ to $-3/16$ inch TOE-IN.

IF READING IS NOT RIGHT, LEAVE TOE-IN GAGE IN PLACE AND GO TO FRAME 5.

IF READING IS RIGHT, GO TO FRAME 6

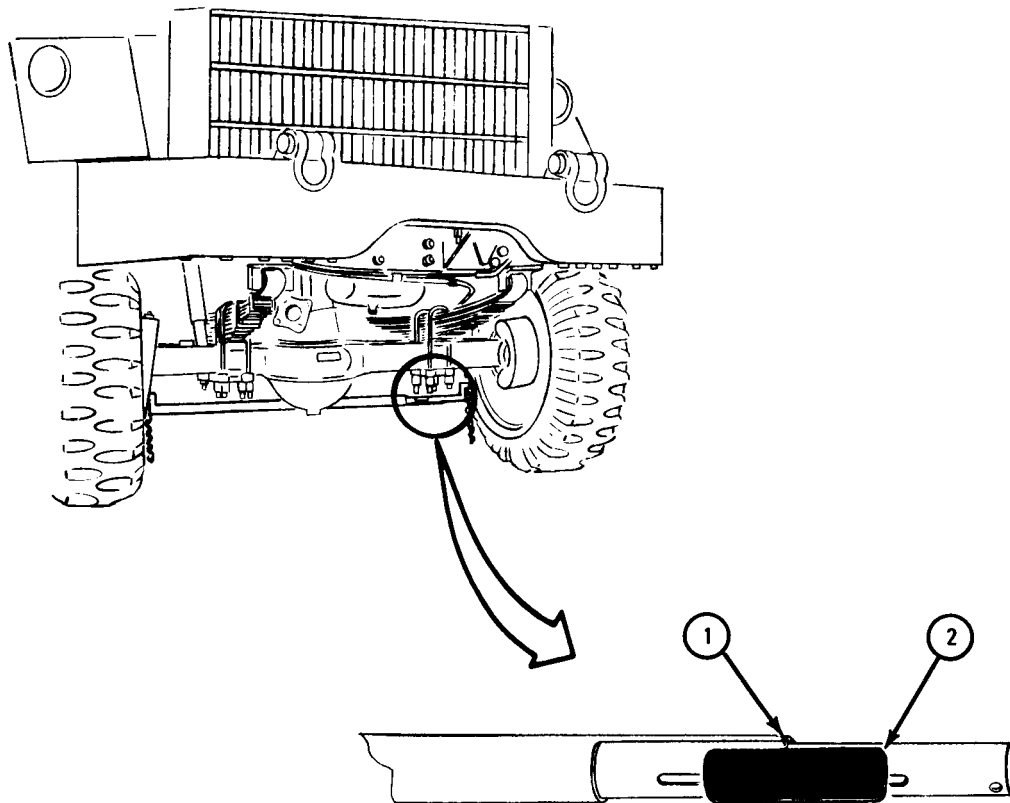

TA 047658

FRAME 5

1. Using 15/16-inch wrench, loosen two nuts (1) at each end of tie rod (2).
2. Using pipe wrench, turn tie rod (2) until pointer (3) reads -1/16 to -3/16 inch TOE-IN on indicator (4).
3. Using 15/16-inch wrench, tighten two nuts (1) at each end of tie rod (2).

GO TO FRAME 6

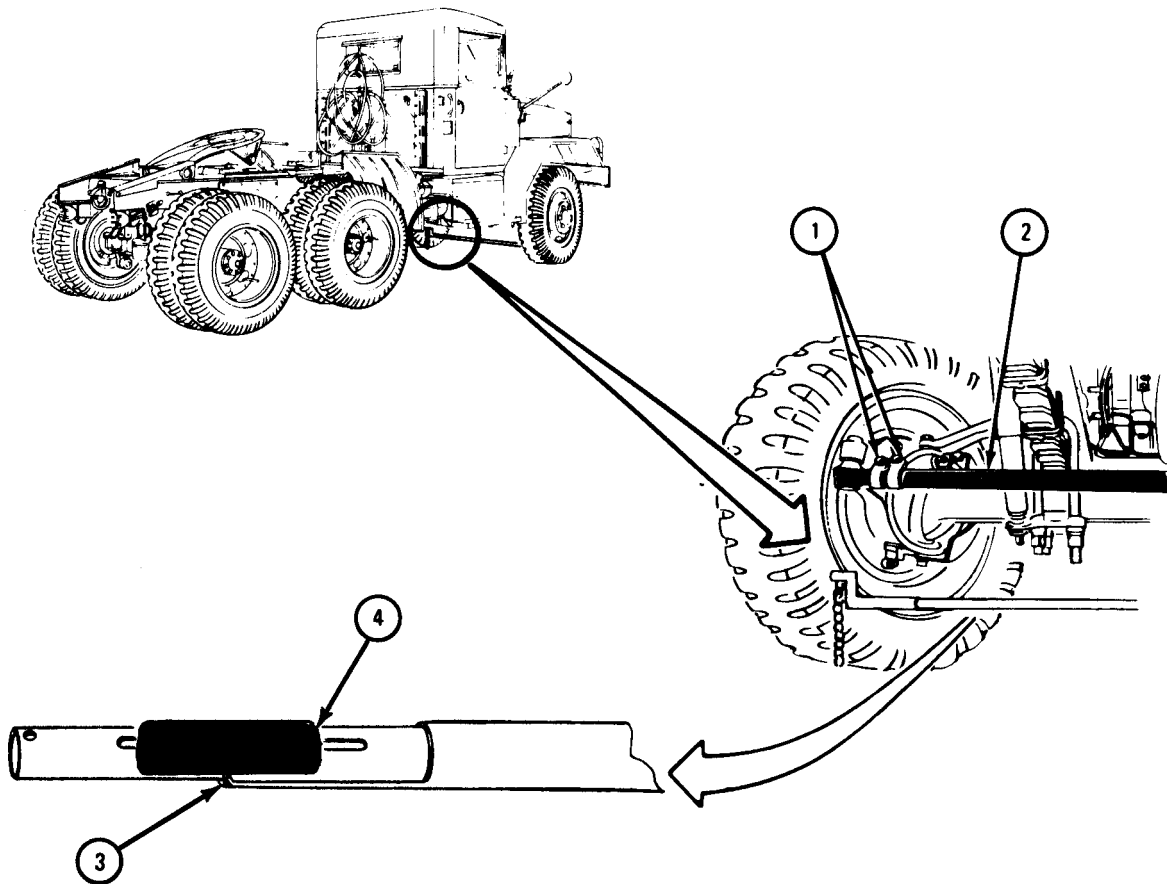

TA 047659

FRAME 6

1. Take off toe-in gage (1).

END OF TASK

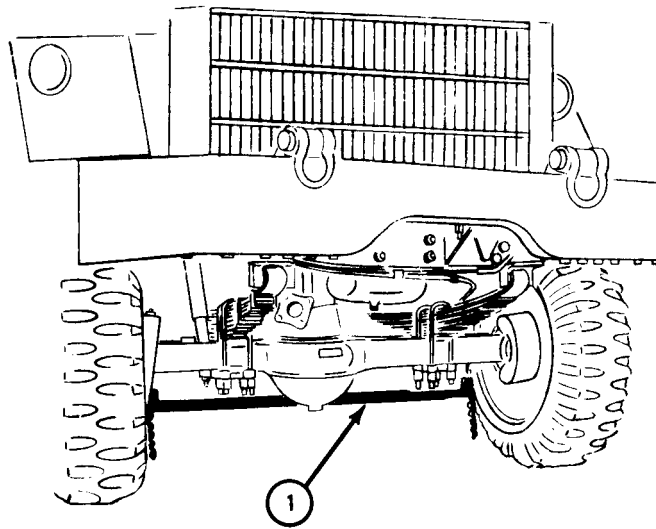

TA 047660

15-4. PITMAN ARM REMOVAL AND REPLACEMENT.

TOOLS: Flat-tip screwdriver
Pliers
Pulley puller
Hammer
1 7/16-inch wrench
Screwdriver bit

SUPPLIES: None

PERSONNEL: One

EQUIPMENT CONDITION: Truck parked, engine off, handbrake set.

a. Removal.

FRAME 1

1. Using pliers, take cotter pin (1) out of drag link end (2).
2. Using screwdriver bit, unscrew adjusting plug (3) until it is almost out of drag link end (2).
3. Go to cab of truck. Turn steering wheel one half turn to the right.

NOTE

When drag link (2) is pulled off pitman arm (4), inner parts can fall out. Be careful not to lose these parts.

4. Pull drag link end (2) off of pitman arm (4).
5. Using 1 7/16-inch wrench, unscrew and take off nut (5).

GO TO FRAME 2

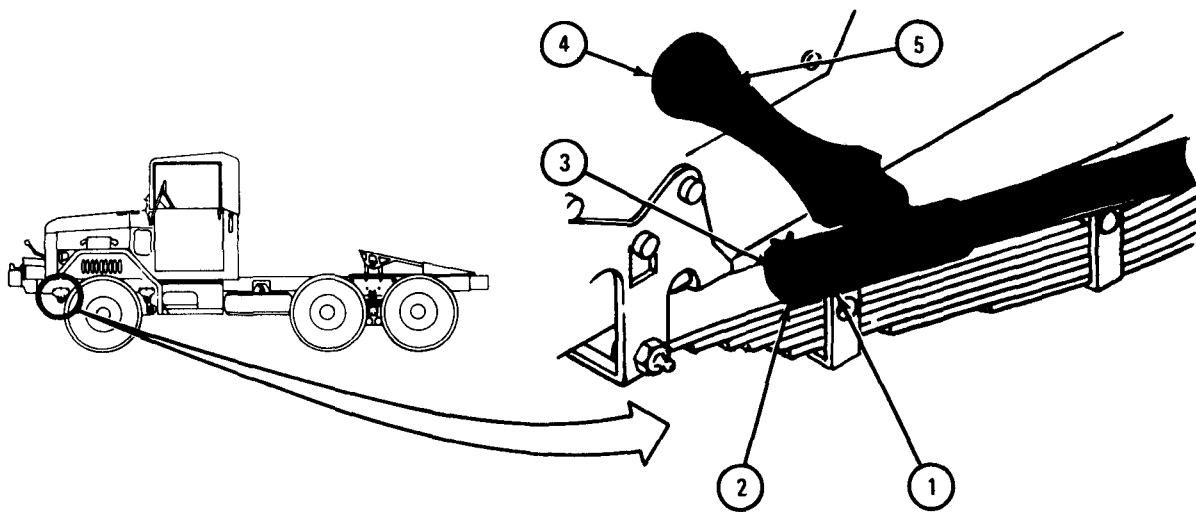

TA 046111

FRAME 2

1. Put pulley puller (1) on pitman arm (2).
2. Using 1 7/16-inch wrench, screw in screw (3). If pitman arm does not come off, tap screw with hammer and screw in screw again.
3. Take pitman arm (2) and pulley puller (1) away.

END OF TASK

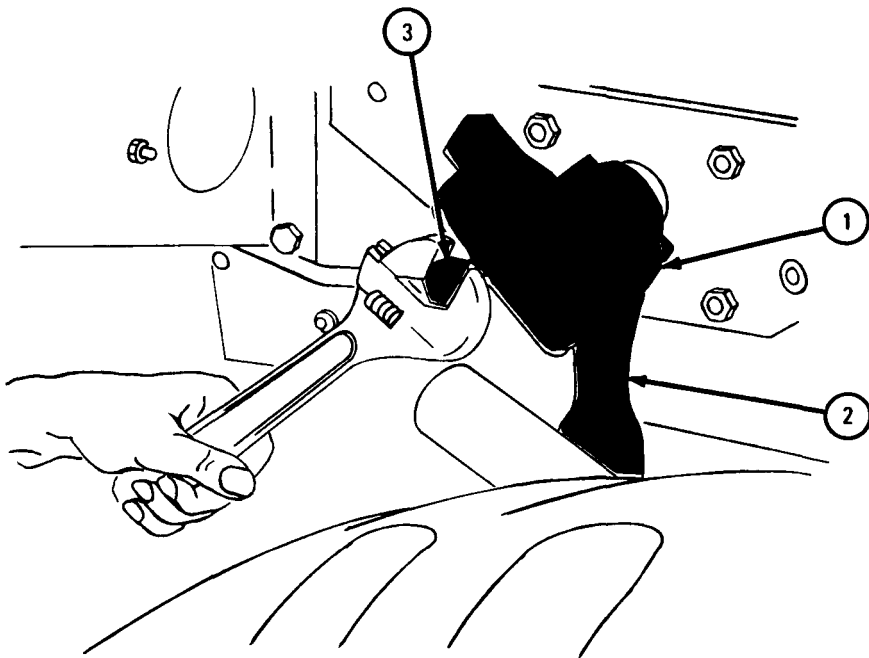

TA 046112

b. Replacement.

FRAME 1

1. Line up marks on pitman arm (1) with marks on end of splined shaft (2) and slide pitman arm onto splined shaft.
2. Tap pitman arm (1) near splined shaft (2) with hammer until screw end of splined shaft comes through. Be careful not to hit splined shaft.
3. Put lockwasher (3) on splined shaft (2). Using 1 7/16-inch wrench, screw on nut (4).

GO TO FRAME 2

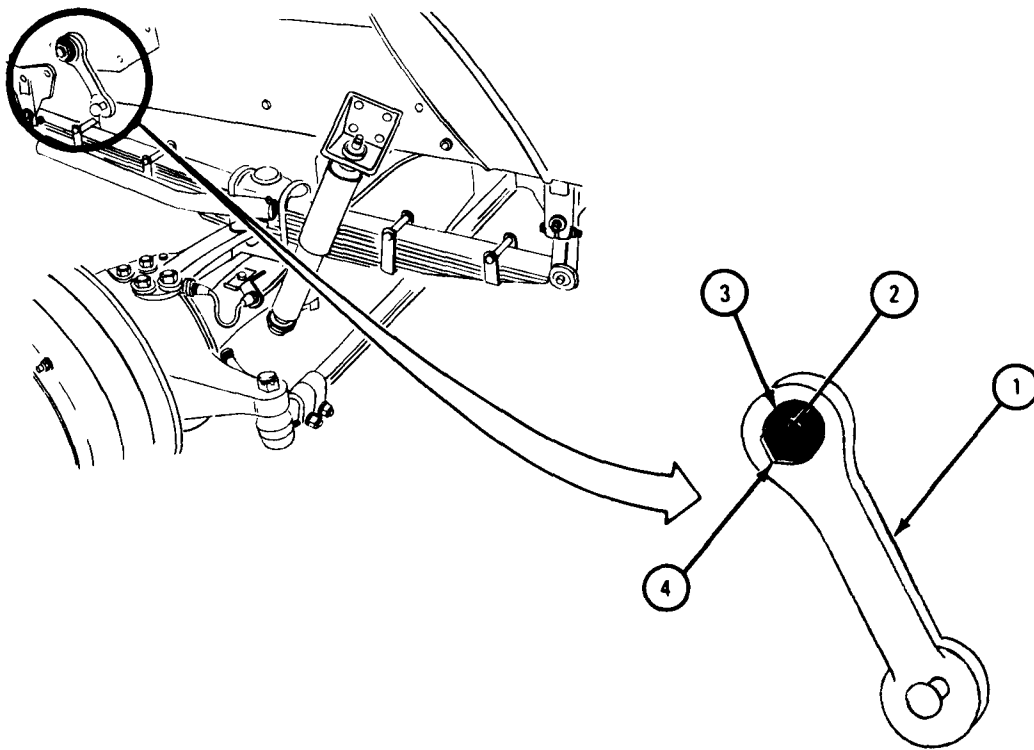

TA 046113

FRAME 2

1. Using screwdriver, unscrew adjusting plug (1). Take out ball seat (2).
2. Turn steering wheel to align large end of slot on drag link end (3) with ball on pitman arm (4).
3. Put slot in drag link end (3) onto ball of pitman arm (4). Put ball seat (2) into drag link end. Using screwdriver, screw in adjusting plug (1) until it is almost all the way in.
4. Lubricate drag link end (3). Refer to LO 9-2320-209-12/1.
5. Using screwdriver bit, screw in adjusting plug (1). Unscrew adjusting plug one half turn or less until cotter pin (5) can be put in. Using pliers, bend open ends of cotter pin.

END OF TASK

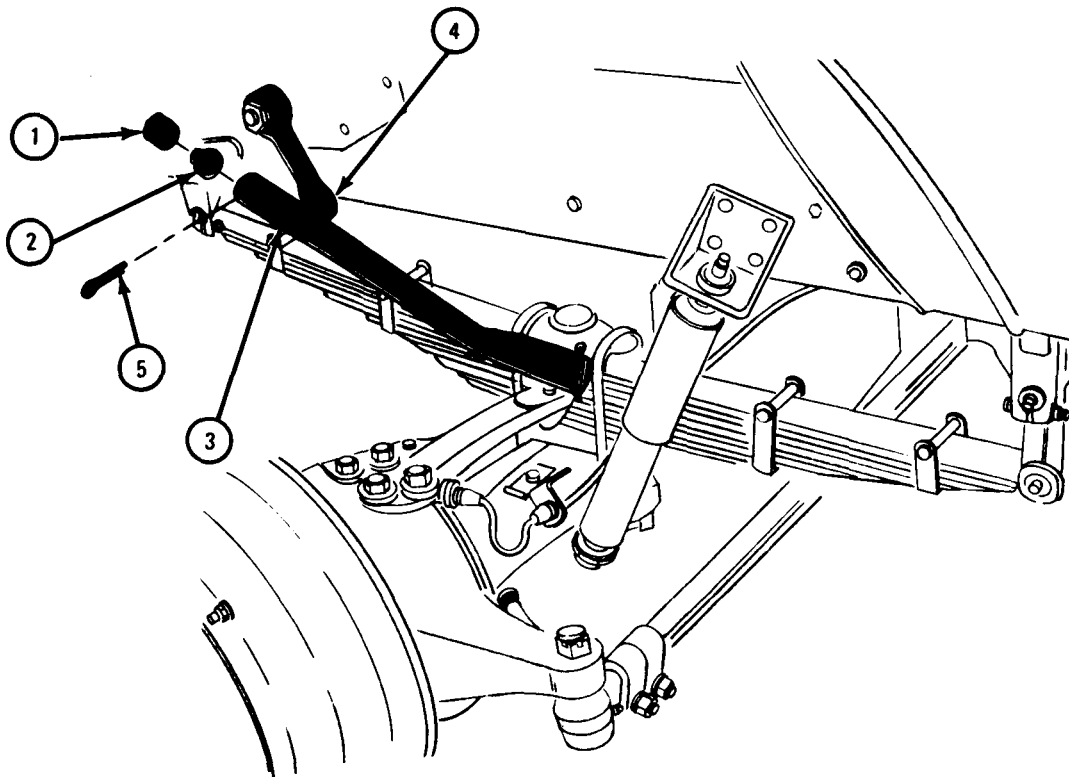

TA 046114

15-5. STEERING GEAR ADJUSTMENT.

TOOLS: Flat-tip screwdriver
3/4-inch wrench
9/16-inch wrench
Diagonal cutters

SUPPLIES: None

PERSONNEL: One

EQUIPMENT CONDITION: Truck parked, engine off, handbrake set.

a. Preliminary Procedure. Remove drag link from pitman arm. Refer to para 15-7.

b. Adjustment.

FRAME 1

1. Using 3/4-inch wrench, loosen locknut (1). Using screwdriver, loosen screw (2).

GO TO FRAME 2

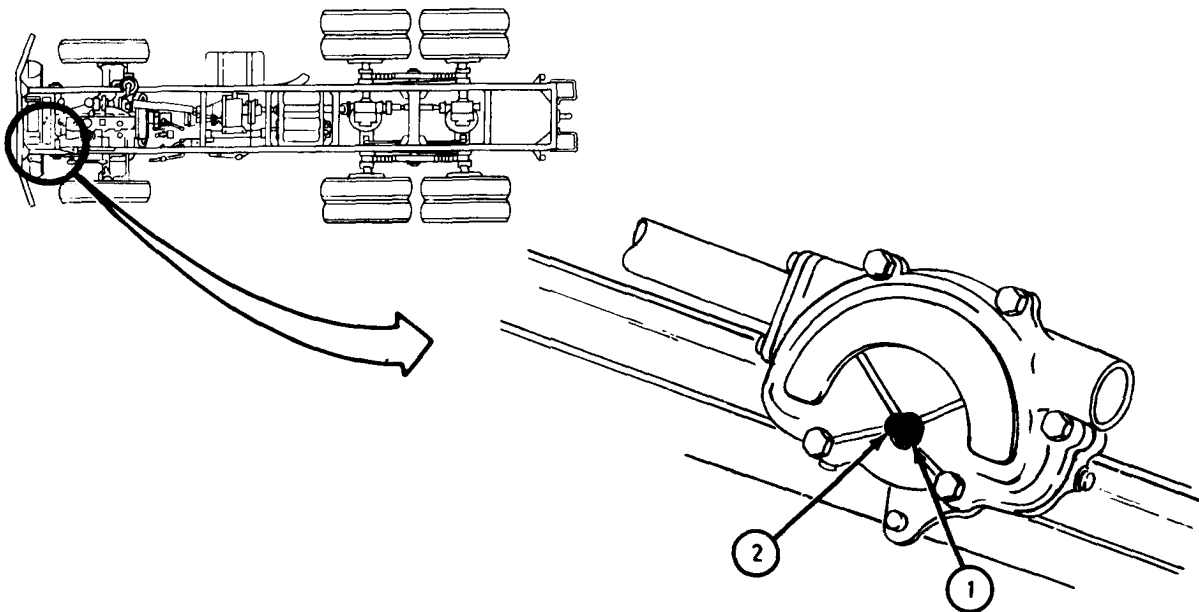

TA 046379

FRAME 2

1. Using 9/16-inch wrench, loosen screw (1) .
2. Hold steering wheel (2) lightly and turn it around.

IF STEERING WHEEL (2) HAS NO DRAG, GO TO FRAME 3 TO SET DRAG.
IF STEERING WHEEL (2) HAS SLIGHT DRAG, GO TO FRAME 4

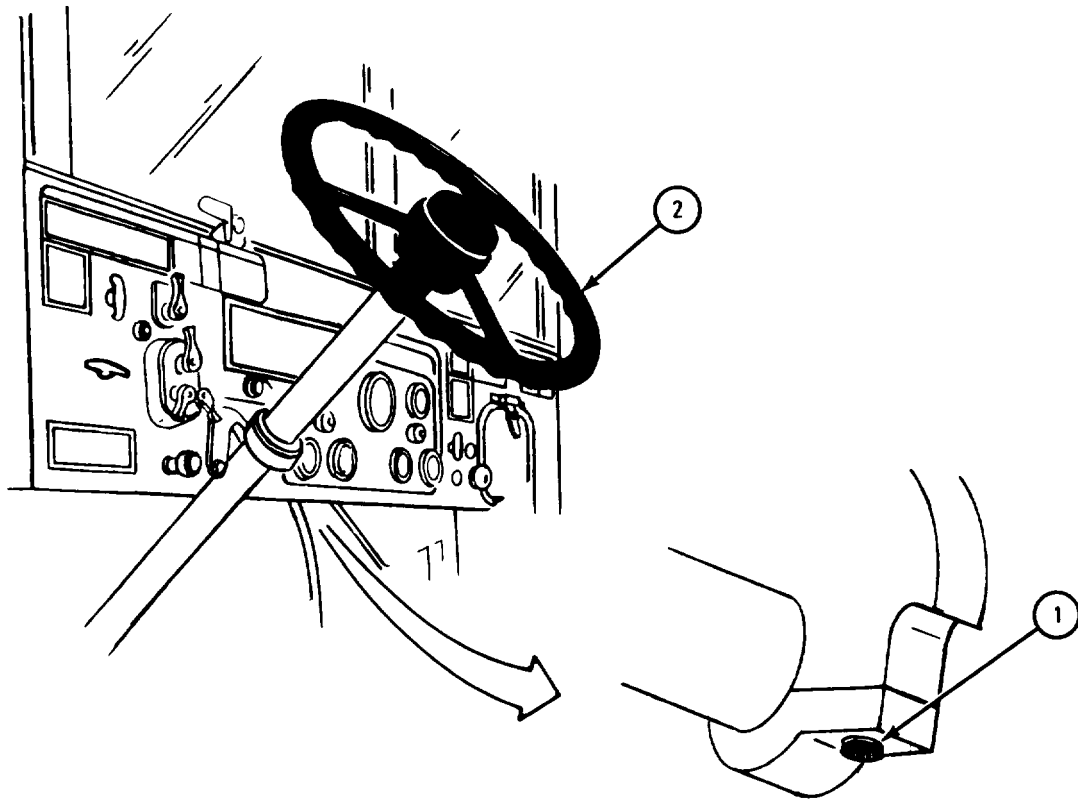

FRAME 3

1. Disconnect horn cable near lower end of steering gear. Refer to Part 1, para 7-54.
2. Using 9/16-inch wrench, unscrew and take out four capscrews (1) and lockwashers (2).
3. Pull steering gear jacket (3) about two inches away from steering gear housing (4).
4. Check over shims (5) until a thin one is found. Using diagonal cutters, cut and take away thin shim.
5. Push steering gear jacket (3) back to steering gear housing (4) keeping screw holes in spacers lined up. Put lockwashers (2) on capscrews (1) and using 9/16-inch wrench, screw in and tighten capscrews.
6. Go to cab of truck and check steering wheel for drag. If drag is not correct, do steps 2 through 5 again. If drag is good, connect horn cable. Refer to Part 1, para 7-54.

GO TO FRAME 4

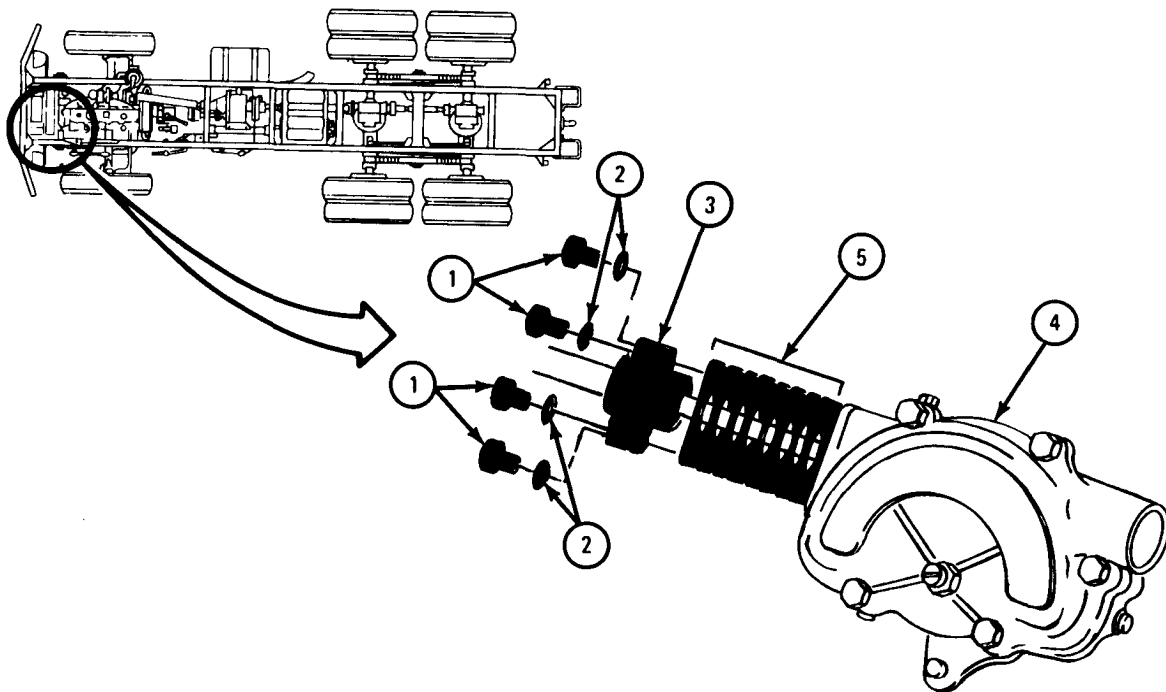

TA 046381

FRAME 4

1. Using 9/16-inch wrench, tighten screw (1).
2. Turn steering wheel (2) all the way to the right. While counting turns, turn steering wheel all the way to the left.
3. Turn steering wheel (2) half the number of turns counted in step 2 to the right. That is the mid-position. Note where it is.

GO TO FRAME 5

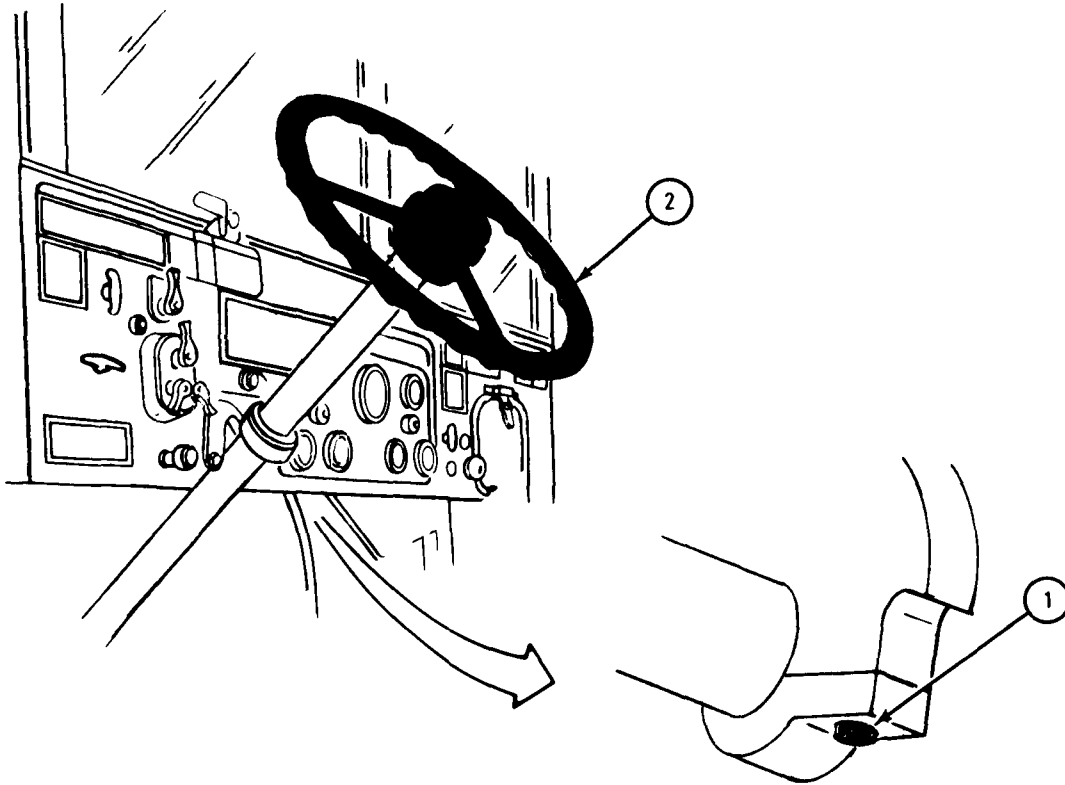

TA 046380

FRAME 5

1. Using screwdriver, screw in screw (1) until it is lightly snug. Hold screw with screwdriver and using 3/4-inch wrench, tighten nut (2).
2. Go to cab of truck and turn steering wheel back and forth one turn around the midposition.
3. If there is a light drag at the midposition, the drag is good. If drag is good, do follow-on maintenance action. If drag is not good, go to frame 6 to set drag.

NOTE

Follow-on Maintenance Action Required:

Replace drag link on pitman arm. Refer to para 15-7.

END OF TASK

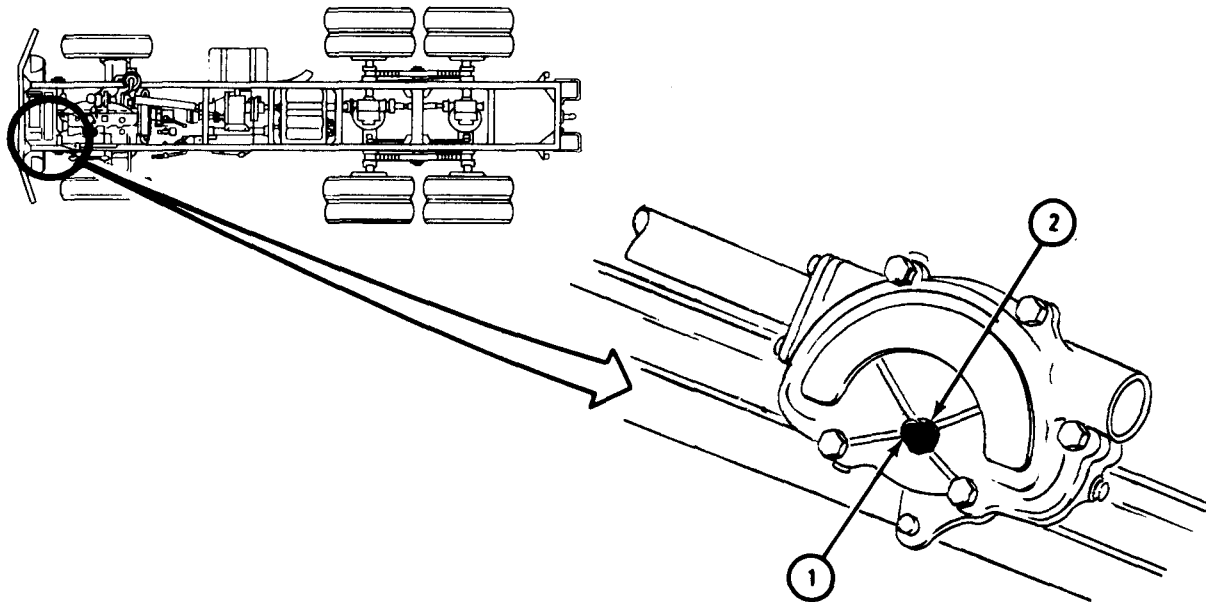

TA 046382

FRAME 6

NOTE

For too much drag, do steps 1 and 2. For not enough drag, do steps 3 and 4.

1. Using screwdriver, hold screw (1). Using 3/4-inch wrench, loosen nut (2). Using screwdriver, unscrew screw (1) a small amount and hold it there while using wrench to tighten nut (2).
2. Go back to frame 5 and start work at step 2.
3. Using screwdriver, hold screw (1). Using 3/4-inch wrench, loosen nut (2). Using screwdriver, screw in screw (1) a small amount and hold it there while using wrench to tighten nut (2).
4. Go back to frame 5 and start work at step 2.

END OF TASK

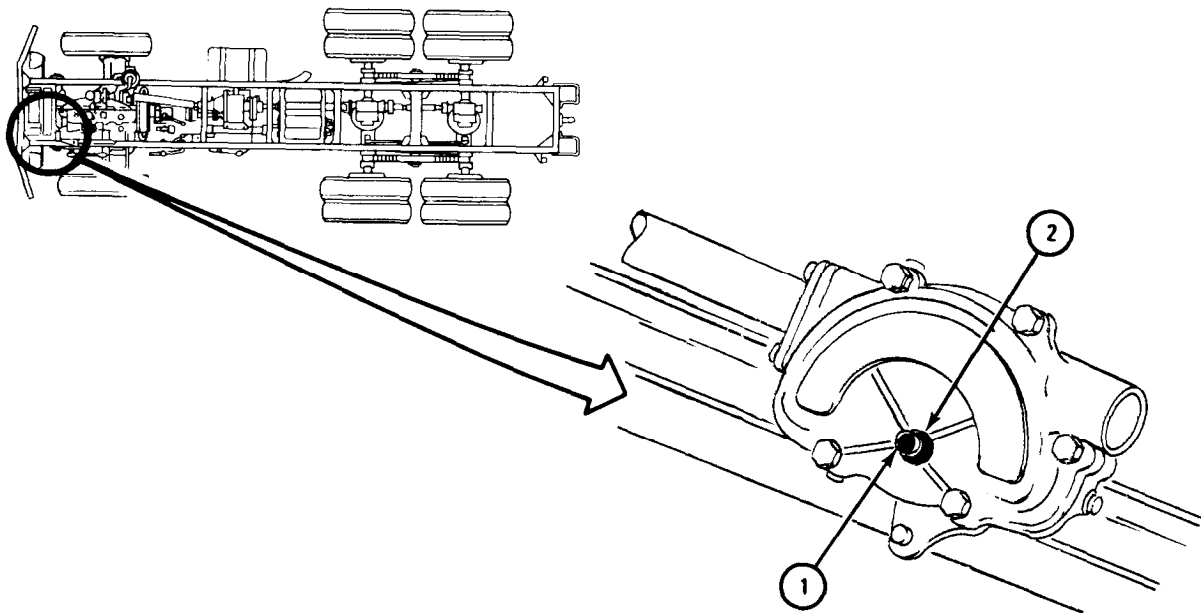

TA 046382

15-6. TIE ROD END REMOVAL AND REPLACEMENT.

TOOLS: Pliers
15/16-inch wrench
Pipe wrench
1 3/8-inch wrench
Fork wedge
Hammer

SUPPLIES: None

PERSONNEL: One

EQUIPMENT CONDITION: Truck parked, engine off, handbrake set, rear wheels chocked.

a. Preliminary Procedure. Jack up front axle housing enough to take weight of truck off front wheels. Refer to Part 1, para 11-3.

b. Removal.

FRAME 1

1. Using 15/16-inch wrench, loosen two nuts (1) until lockwashers (2) do not hold.
2. Using pliers, take out cotter pin (3).
3. Using 1 3/8-inch wrench, unscrew nut (4).
4. Using fork wedge and hammer, take tie rod end (5) out of steering knuckle (6).

GO TO FRAME 2

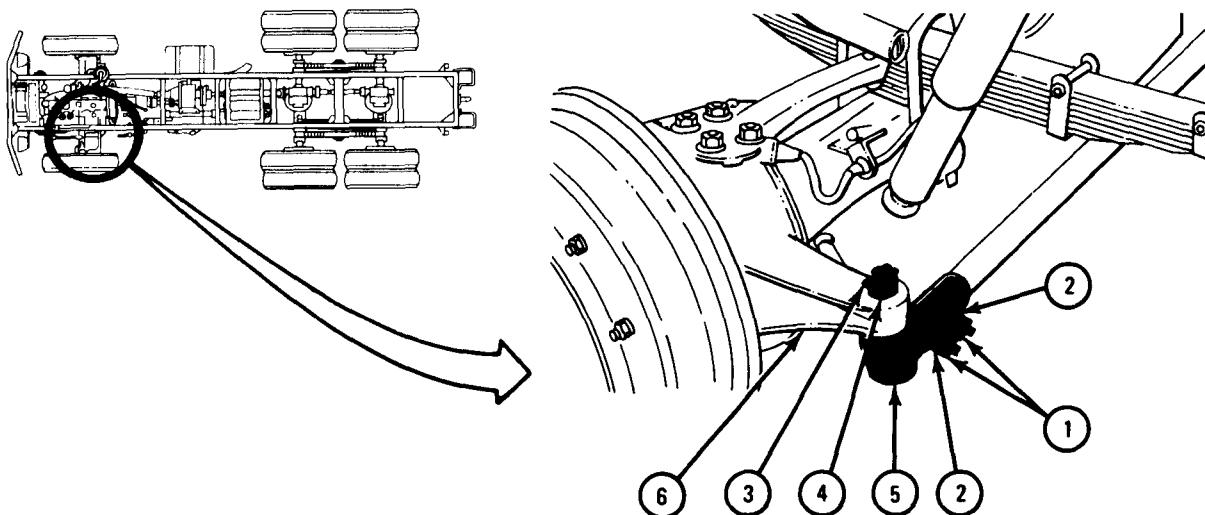

TA 046196

FRAME 2

NOTE

Procedure is the same for both tie rod ends except that on left side of truck, tie rod end has left hand threads. On right side of truck, tie rod end has right hand threads.

1. Using pipe wrench, unscrew tie rod end (1) from tie rod (2). Count how many turns it takes to unscrew tie rod end off.
2. Jack truck down. Refer to Part 1, para 11-3.

END OF TASK

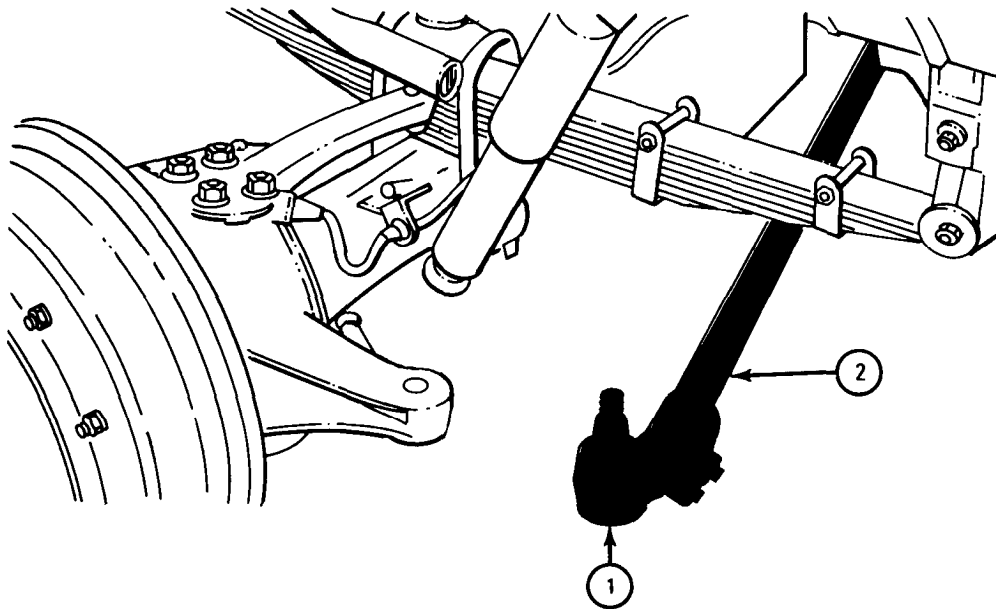

TA 046197

c. Replacement.

FRAME 1

NOTE

Procedure is the same for both tie rod ends except that on left side of truck, tie rod end has left hand threads. On right side of truck, tie rod end has right hand threads.

1. Using pipe wrench, screw tie rod end (1) into tie rod (2). Screw it in the same number of turns it took to take it off. Be careful not to damage dust cover (3).

GO TO FRAME 2

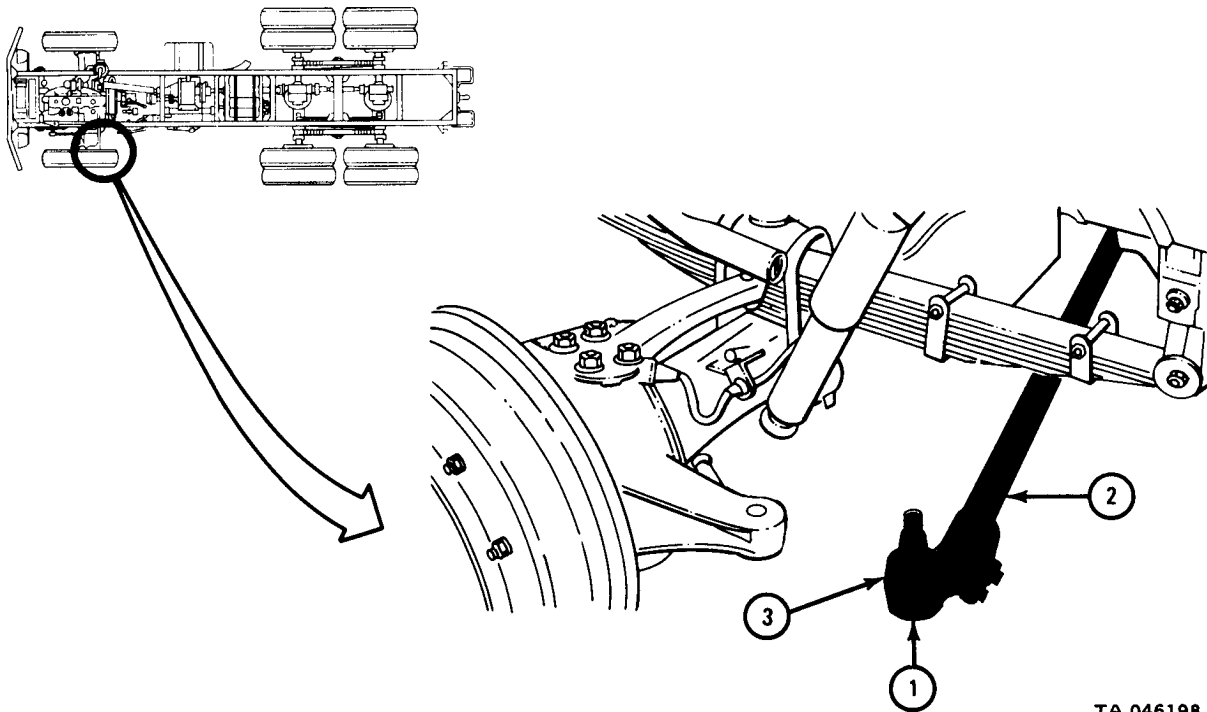

TA 046198

FRAME 2

1. Jack up tie rod (1) as close to steering knuckle (2) as possible.
2. Put tie rod end (3) into steering knuckle (2).
3. Using 1 3/8-inch wrench, screw on nut (4) all the way.
4. Put cotter pin (5) through nut (4) and tie rod end (3). If cotter pin holes are not lined up, unscrew nut only until they do.
5. Using pliers, bend ends of cotter pin (5) around nut (4).
6. Using 15/16-inch wrench, tighten two nuts (6).
7. Take jack away from tie rod (1).

NOTE

Follow-on Maintenance Action Required:

Adjust toe-in. Refer to para 15-3.

END OF TASK

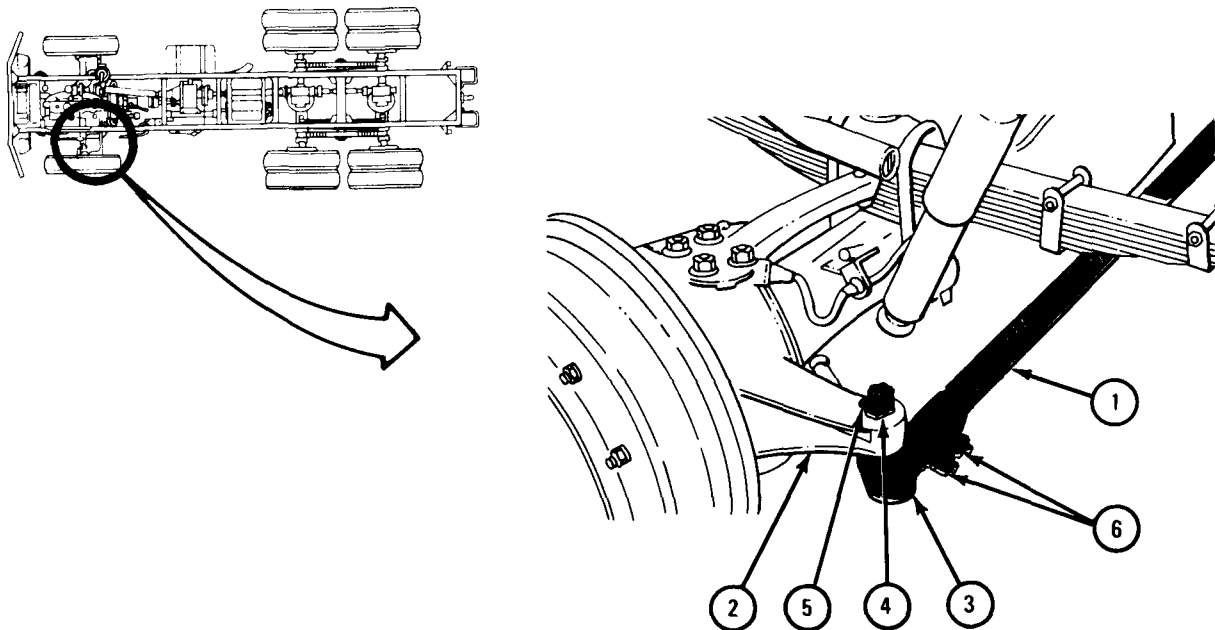

TA 046199

15-7. DRAG LINK ASSEMBLY REMOVAL AND REPLACEMENT.

TOOLS: Pliers
Screwdriver bit

SUPPLIES: None

PERSONNEL: One

EQUIPMENT CONDITION: Truck parked, engine off, handbrake set, rear wheels chocked.

a. Preliminary Procedure. Jack up front of truck chassis. Put safety jacks under frame. Refer to Part 1, para 11-4.

b. Removal.

FRAME 1

1. Using pliers, take cotter pin (1) out of drag link (2).
2. Using screwdriver bit, unscrew adjusting plug (3) until it is out of drag link (2).
3. Do steps 1 and 2 again on other end of drag link (2).

GO TO FRAME 2

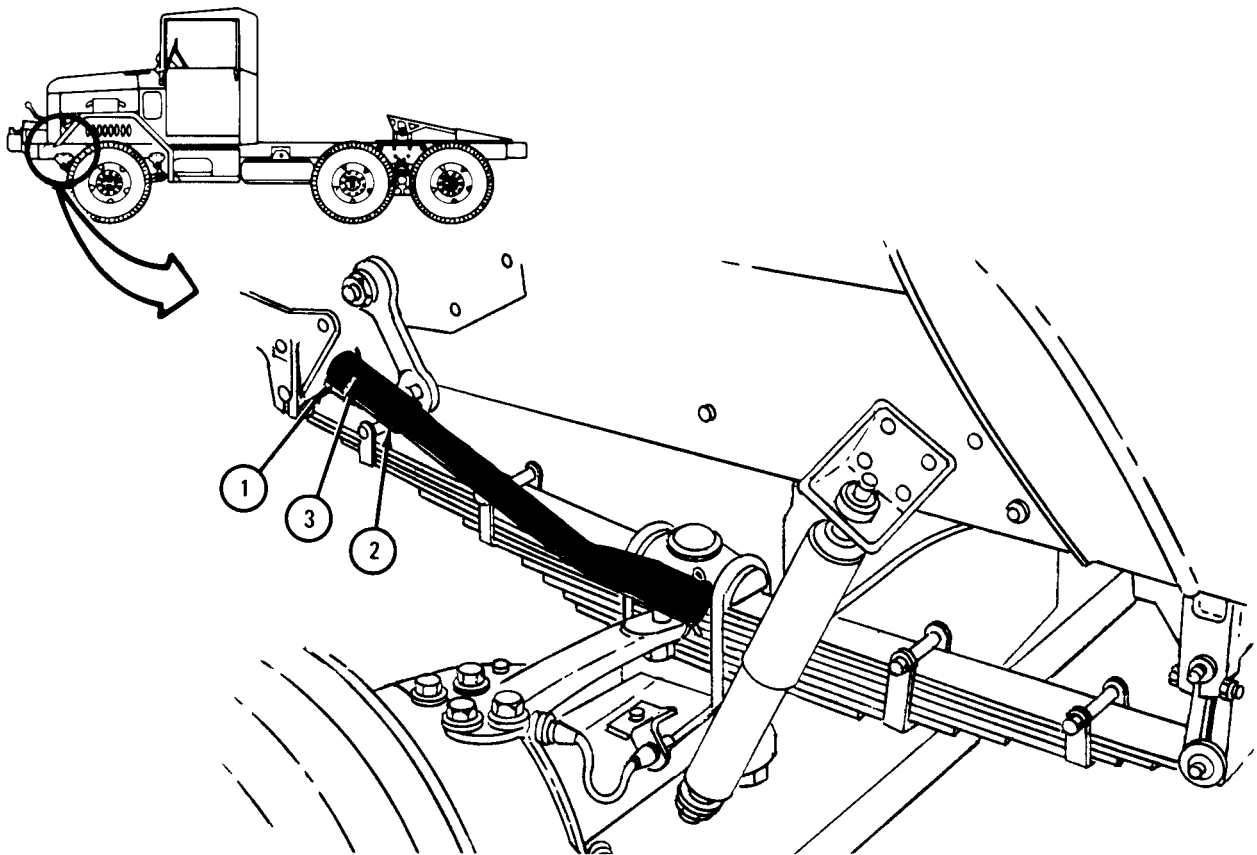

TA 046272

FRAME 2

1. Working in cab of truck, turn steering wheel to the left or right as needed.
2. Working under truck, take out safety plug (1). Take drag link (2) out of pitman arm (3).
3. Put end of drag link (2) down toward ground. Take spring (4) and two ball seats (5) out of drag link.

GO TO FRAME 3

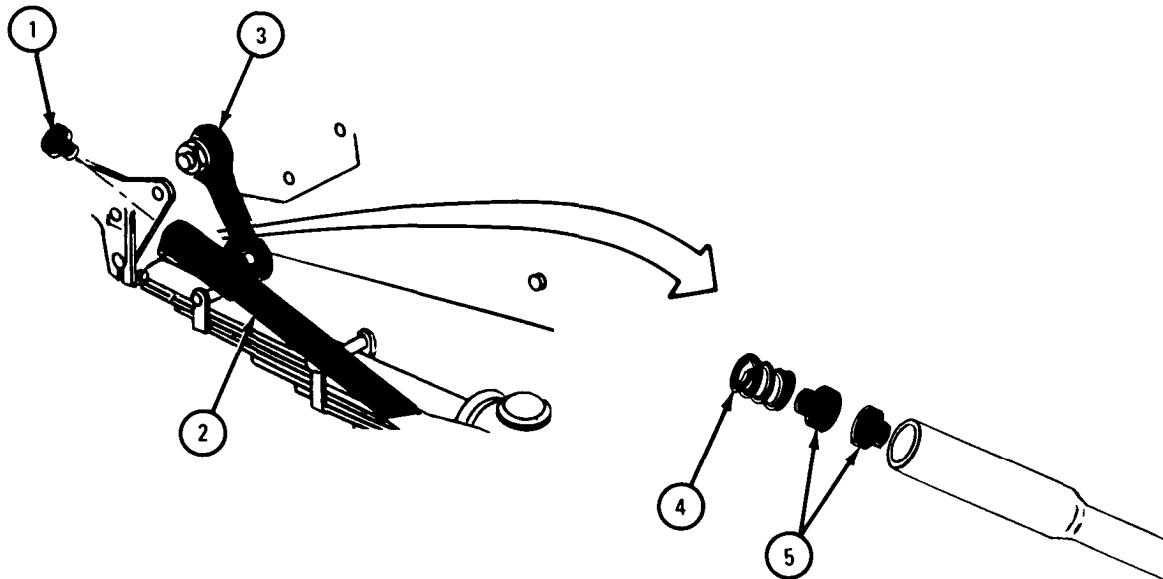

TA 046273

FRAME 3

1. Take out ball seat (1). Lift drag link (2) up and off steering arm (3).
2. Point end of drag link (2) down toward ground. Take ball seat (4), spring (5), and safety plug (6) out of drag link.

END OF TASK

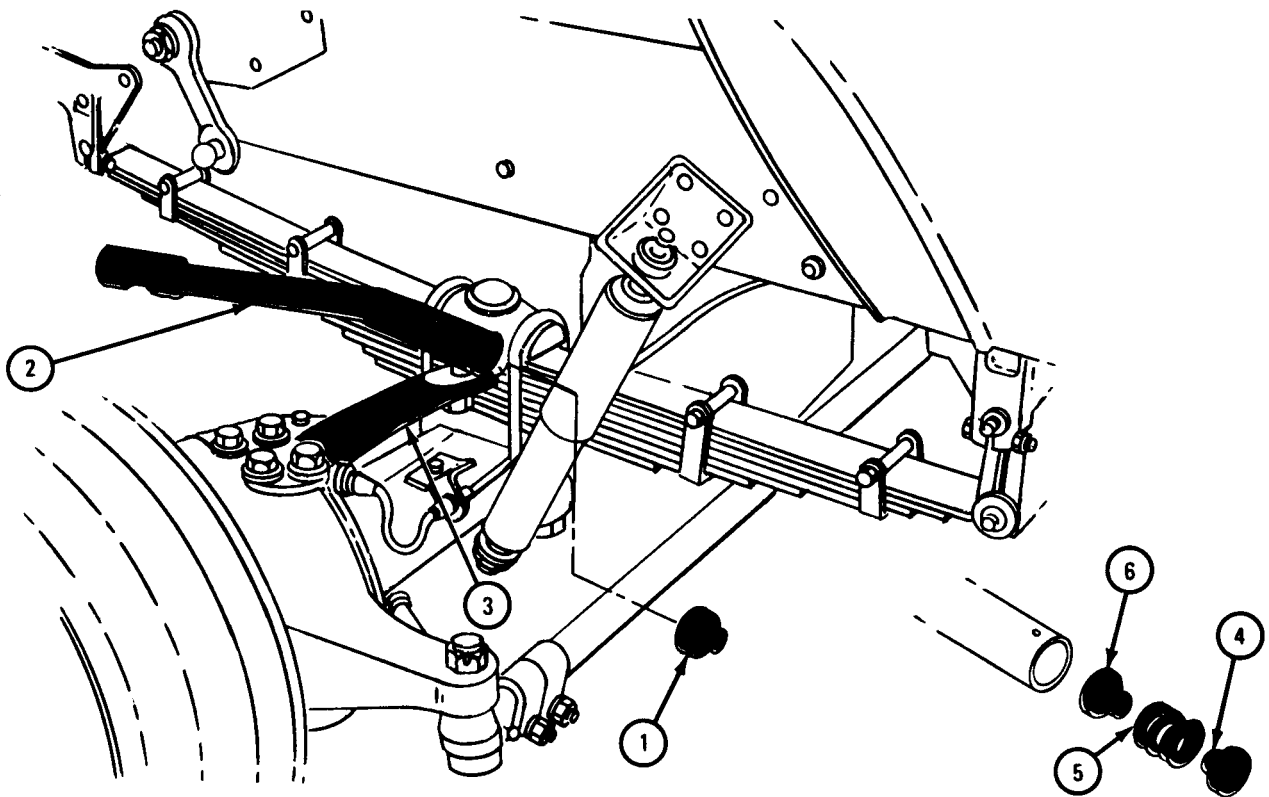

TA 046274

c. Replacement.

FRAME 1

1. Check openings (1 and 2) in side of drag link (3) to see which end has opening closer to end. The end of drag link with opening (1) is the steering arm end of drag link.

CAUTION

How safety plug (4) and spring (5) go in is important.
Make sure they are put in as shown.

2. Put safety plug (4), spring (5) and ball seat (6) into steering arm end of drag link (3).

GO TO FRAME 2

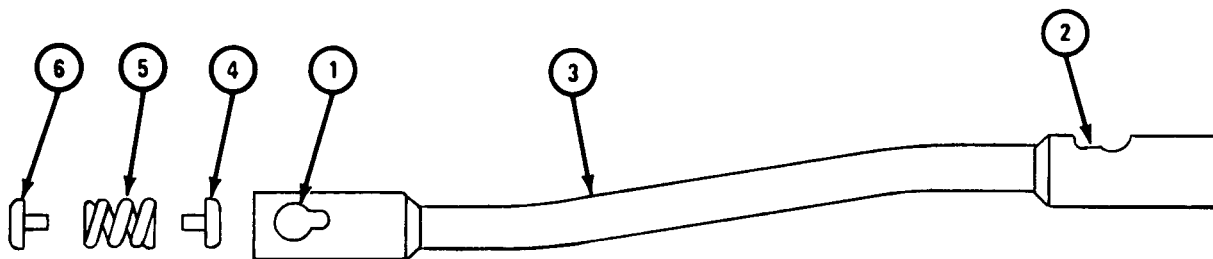

TA 046275

FRAME 2

1. Put steering arm end of drag link (1) onto steering arm ball (2). Make sure ball seat (3) in drag link is caught. Push drag link down until ball goes into opening.
2. Put other ball seat (4) into drag link (1). Using screwdriver bit, screw in adjusting plug (5).

GO TO FRAME 3

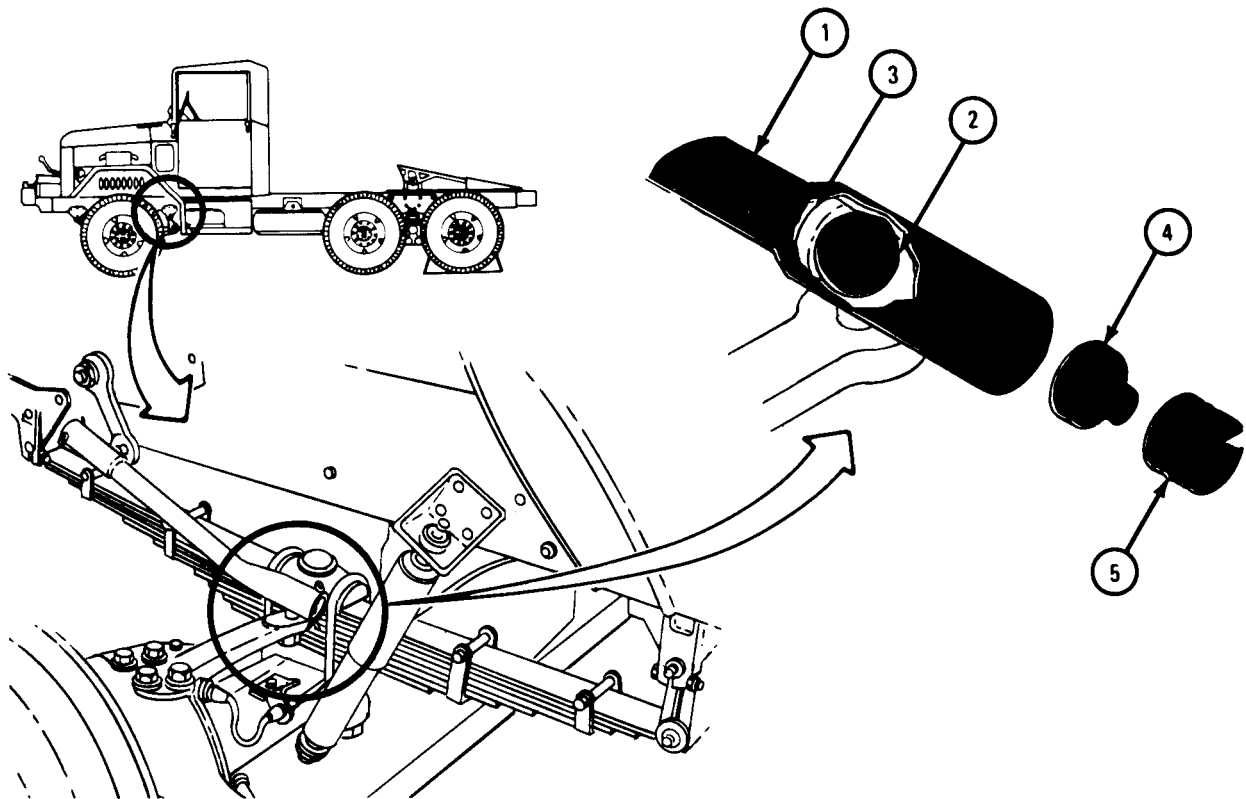

TA 046276

FRAME 3

1. Put ball seat (1) into drag link (2) with the cup side toward open end of drag link.
2. Put drag link (2) onto pitman arm ball (3). Make sure ball seat (1) in drag link is caught.
3. Put in other ball seat (4) with cup side toward pitman arm ball (3). Put in spring (5) and safety plug (6).
4. Using screwdriver bit, screw in adjusting plug (7).

GO TO FRAME 4

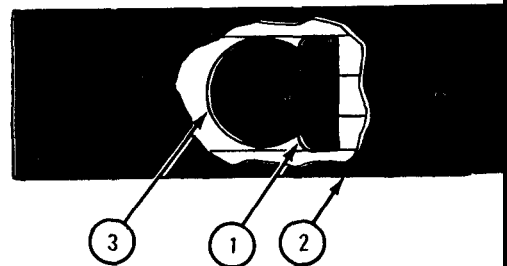
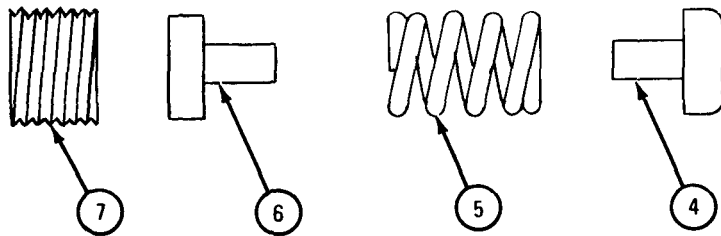
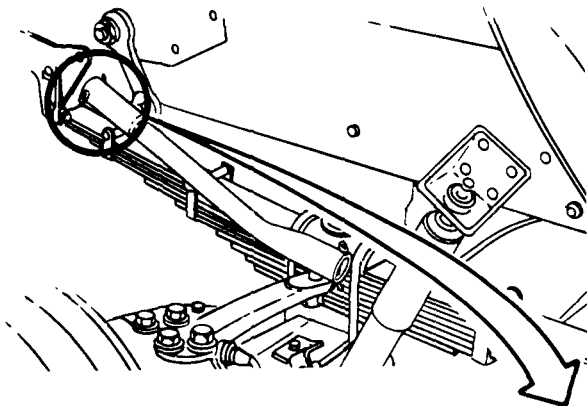

TA 046277

FRAME 4

1. Lubricate drag link. Refer to LO 9-2320-209-12/1.
2. Using screwdriver bit, screw in and tighten adjusting plug (1). Unscrew adjusting plug one half turn or less, until cotter pin slot lines up with holes.
3. Put cotter pin (2) through drag link (3). Using pliers, open ends of cotter pin.
4. Go to pitman arm (4) end of drag link (3). Do steps 2 and 3 again on that end of drag link.
5. Take safety jacks away. Jack truck chassis down. Refer to Part 1, para 11-4.

END OF TASK

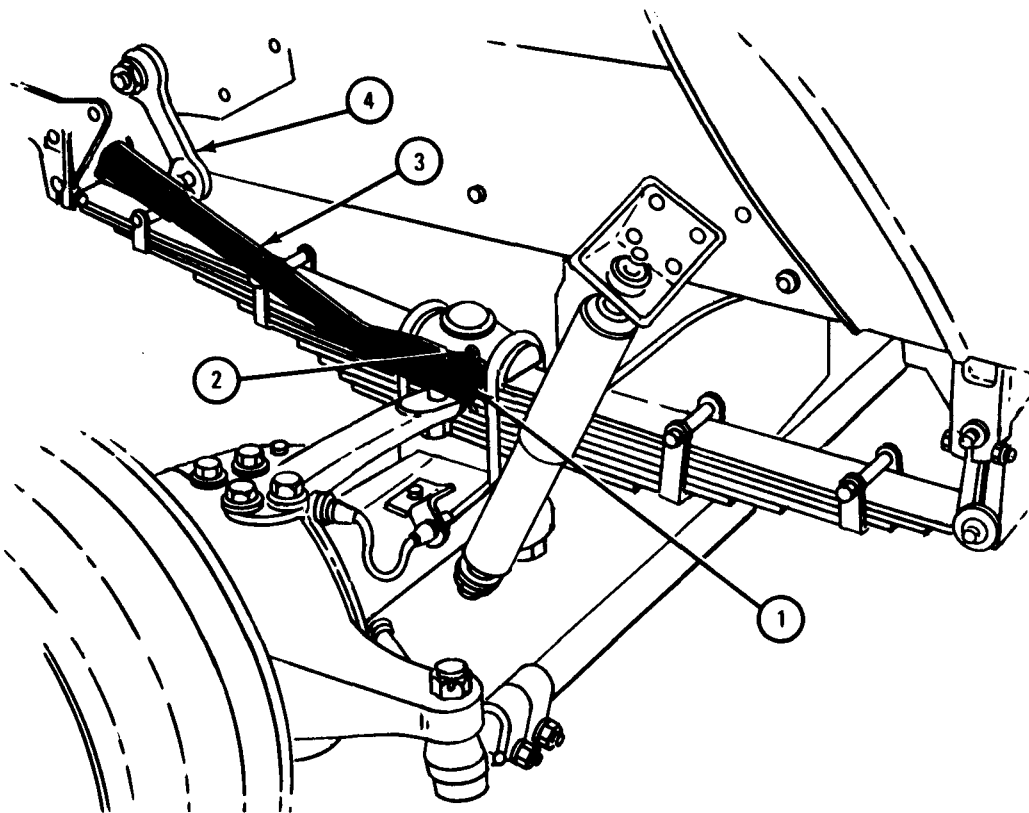

TA 046278

15-8. DRAG LINK ASSEMBLY REPAIR.

TOOLS: Six-point 7/16-inch wrench

SUPPLIES: Solvent, dry cleaning, type II (SD-20), Fed. Spec P-D-680

PERSONNEL: One

EQUIPMENT CONDITION: Truck parked, engine off, handbrake set.

FRAME 1

NOTE

Repair of drag link assembly is limited to the replacement of parts found damaged during inspection.

1. Remove drag link assembly. Refer to para 15-7. All parts except grease fittings are off drag link when drag link assembly is taken out.
2. If grease fittings (1) are bad, using wrench, unscrew them from drag link (2). Using wrench, screw in new fittings.

WARNING

Dry cleaning solvent is flammable. Do not use near an open flame. Keep a fire extinguisher nearby when solvent is used. Use only in well-ventilated places. Failure to do this may result in injury to personnel and damage to equipment.

3. Using solvent, clean all parts. Check all parts. Throw away bad parts and get new parts in their place.
4. Replace drag link assembly. Refer to para 15-7.

END OF TASK

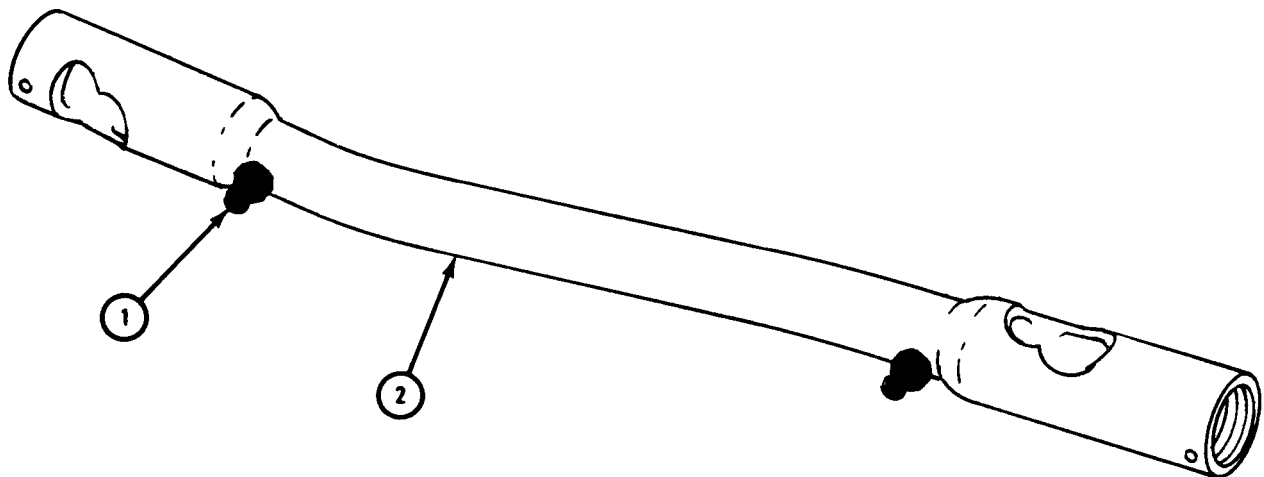

TA 046279

15-9. DRAG LINK ADJUSTMENT.

TOOLS: Pliers
Screwdriver bit

SUPPLIES: Cotter pin (2)

PERSONNEL: One

EQUIPMENT CONDITION: Truck parked, engine off, handbrake set, wheels chocked.

FRAME 1

1. Lubricate drag link. Refer to LO 9-2320-209-12/1.
2. Using pliers, take cotter pin (1) out of drag link (2).
3. Using screwdriver bit, screw in and tighten adjusting plug (3). Unscrew adjusting plug one-half turn or less, until cotter pin slot lines up with holes.
4. Put cotter pin (1) through drag link (2). Using pliers, open ends of cotter pin.
5. Do steps 1 through 4 again on other end of drag link (2).

END OF TASK

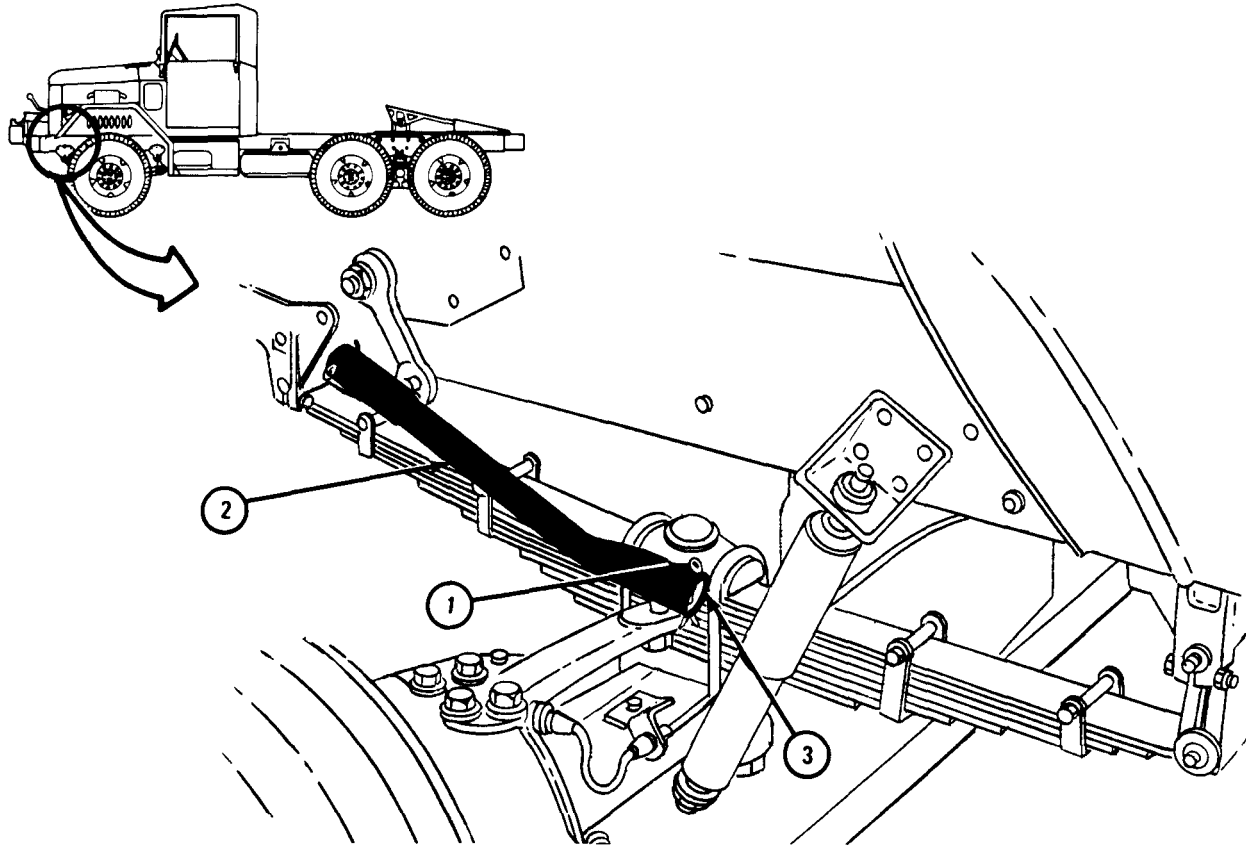

TA 046272

15-10. STEERING WHEEL REMOVAL AND REPLACEMENT.

TOOLS: 1 1/8-inch socket wrench
1 1/4-inch socket wrench
5/6-inch sockethead screw key (Allen wrench or equivalent)
Steering wheel puller, pn 7083305
Flat-tip screwdriver
Mallet, 3 pound

SUPPLIES: None

PERSONNEL: One

EQUIPMENT CONDITION: Truck parked, engine off, handbrake set.

a. Preliminary Procedures.

- (1) Disconnect battery ground cable. Refer to Part 1, para 7-58.
- (2) Remove horn button from steering wheel. Refer to Part 1, para 7-52.
- (3) Remove horn cable from steering column. Refer to Part 1, para 7-54.

b. Removal.

FRAME 1

1. Using screwdriver, loosen clamp screw (1). Slide turn signal control (2) down on steering column (3).

NOTE

If truck does not have air brake hand control valve, do not do step 2.

2. Using 5/16-inch allen wrench, loosen two screws (4). Slide air brake hand control valve (5) down on steering column (3).

GO TO FRAME 2

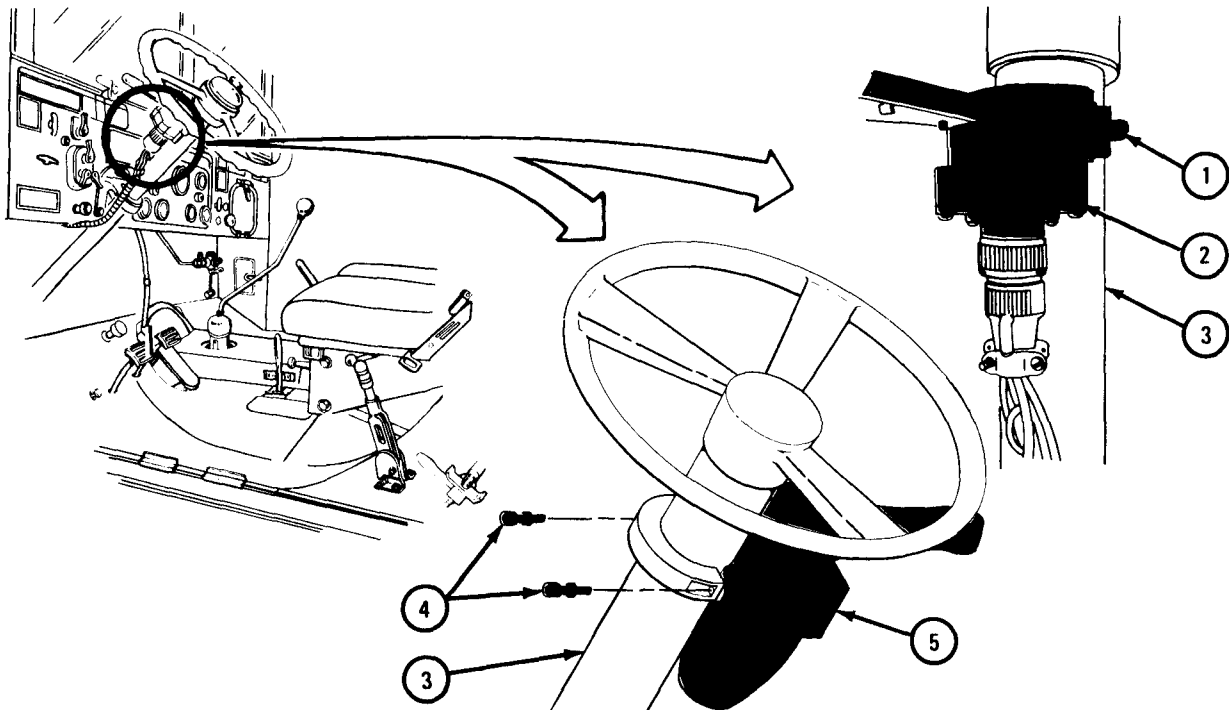

TA 080877

FRAME 2

1. Using 1 1/4-inch wrench, unscrew nut (1) until it is level with top of shaft (2).

GO TO FRAME 3

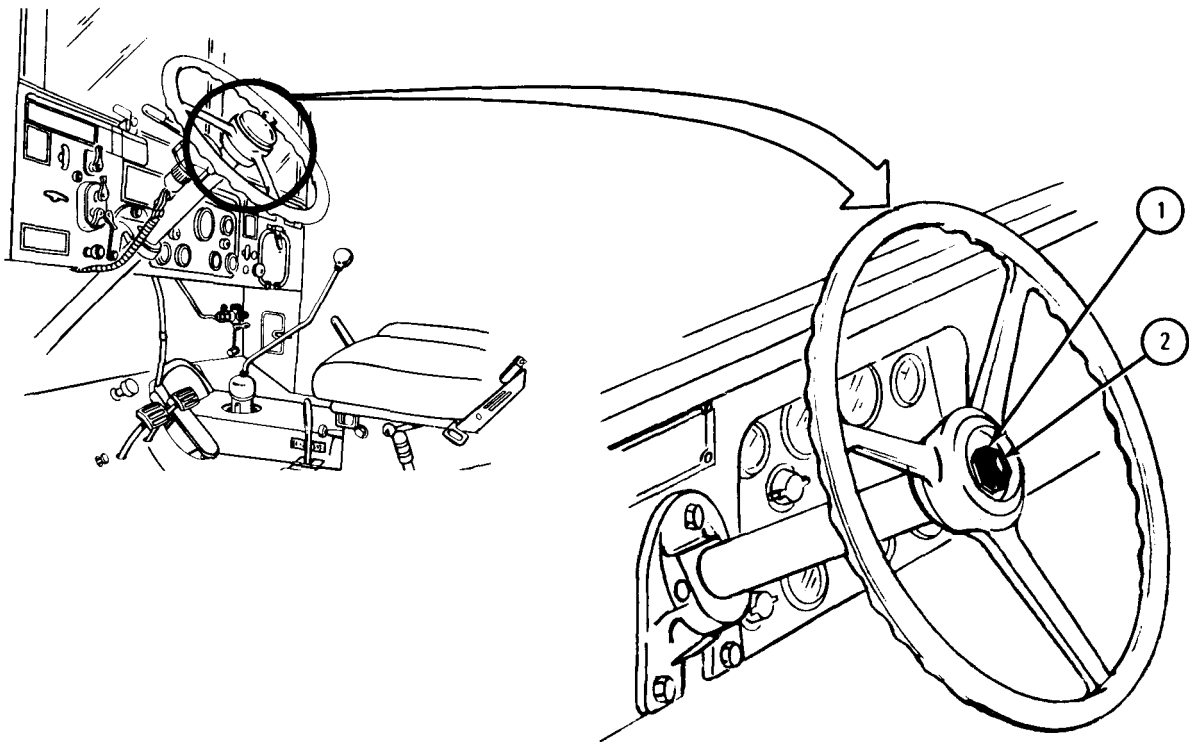

TA 046390

FRAME 3

1. Turn steering wheel (1) to the drive straight ahead position.
2. Put adapter (2) in center of steering wheel nut (3).
3. Put adapter (4) over steering column.
4. Put puller (5) over adapters (2 and 4) as shown.
5. Using 1 1/8-inch wrench, screw in puller screw (6) until steering wheel (1) pops loose.
6. Take off puller (5) and adapters (2 and 4).
7. Using 1 1/4-inch wrench, unscrew and take off nut (3).
8. Take off steering wheel (1).

END OF TASK

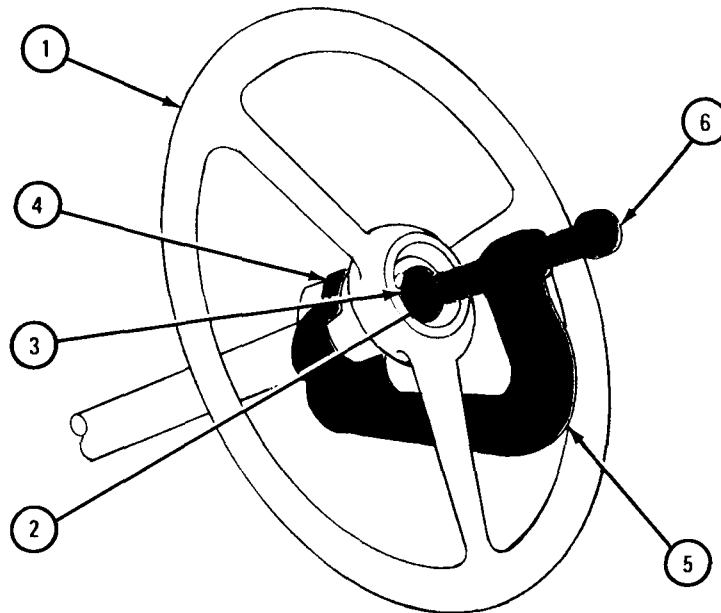

TA 046391

c. Replacement.

FRAME 1

1. Hold steering wheel (1) in the drive straight ahead position. Put steering wheel on shaft that comes out of steering column (2).
2. Using mallet, tap steering wheel down enough so nut (3) can be screwed on. Using 1 1/4-inch wrench, screw on and tighten nut.

GO TO FRAME 2

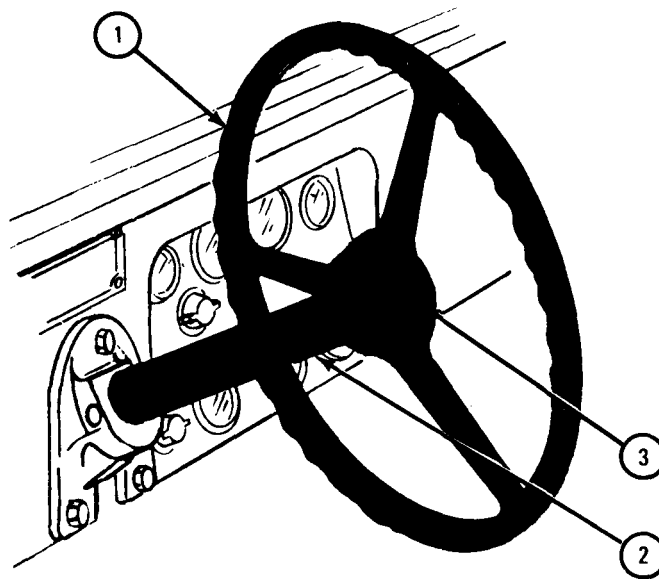

TA 046392

FRAME 2

NOTE

If truck does not have air brake hand control valve, do not do step 1.

1. Slide air brake hand control valve (1) up on steering column (2). Using 5/16-inch allen wrench, tighten two screws (3).
2. Slide turn signal control (4) up on steering column (2). Using screwdriver, tighten clamp screw (5).

NOTE

Follow-on Maintenance Action Required:

1. Replace horn cable. Refer to Part 1, para 7-54.
2. Replace horn button. Refer to Part 1, para 7-52.
3. Reconnect battery ground cable. Refer to Part 1, para 7-58.

END OF TASK

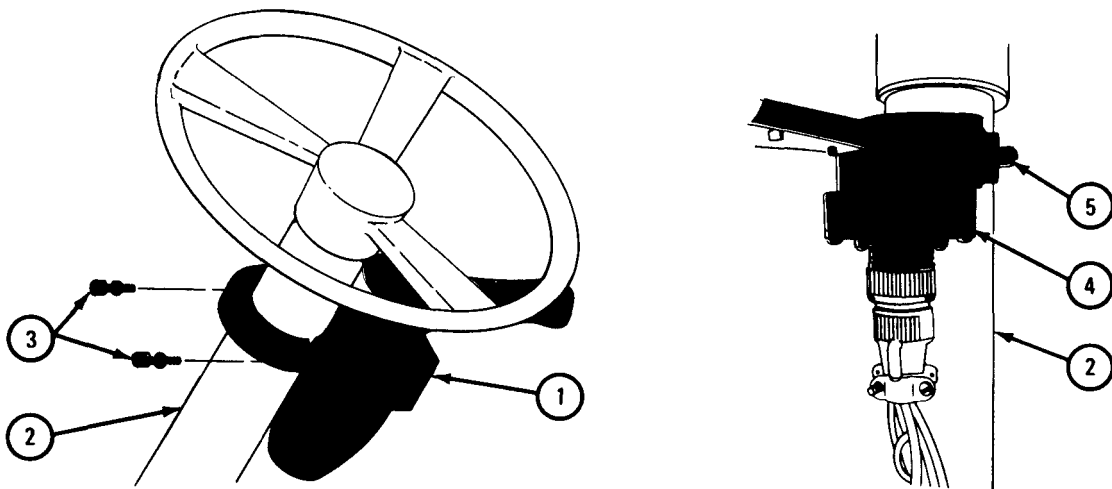

TA 080878

CHAPTER 16

FRAME AND TOWING ATTACHMENTS

GROUP MAINTENANCE

Section I. SCOPE

16-1. EQUIPMENT ITEMS COVERED. This chapter gives equipment maintenance procedures for the pintle and towing attachments, spare wheel carrier, and fifth wheel assembly for which there are authorized corrective maintenance tasks at the organizational maintenance level.

16-2. EQUIPMENT ITEMS NOT COVERED. All equipment items for which corrective maintenance is authorized at the organizational maintenance level are covered in this chapter.

Section II. PINTLE AND TOWING ATTACHMENTS

16-3. FRONT LIFTING SHACKLE REMOVAL AND REPLACEMENT.

TOOLS: 3/4-inch wrench or 3/4-inch socket ratchet wrench (2)
15/16-inch wrench (2) or 15/16-inch socket ratchet wrench (2)

SUPPLIES: None

PERSONNEL: One

EQUIPMENT CONDITION: Truck parked, engine off, handbrake set.

a. Preliminary Procedure. Remove brush guard from trucks without front winch. Refer to Part 1, para 6-4.

b. Removal.

FRAME 1

1. Take clip (1) out of retaining pin (2). Take retaining pin out of lifting shackle (3), and take shackle off bracket (4).

FOR TRUCKS WITHOUT FRONT WINCH, GO TO FRAME 2.
FOR TRUCKS WITH FRONT WINCH, GO TO FRAME 3

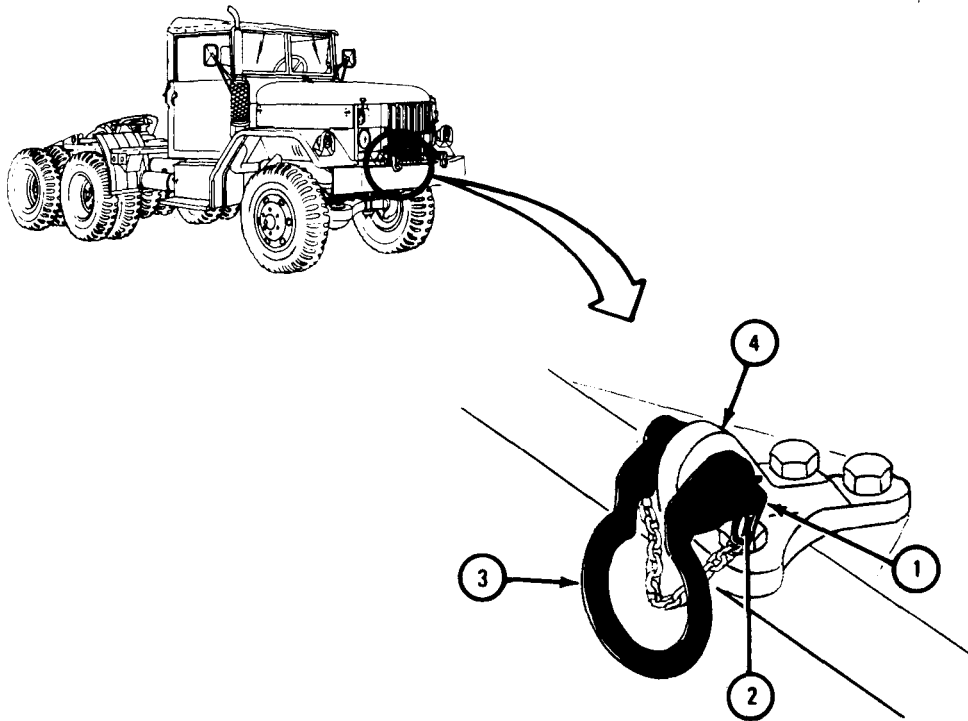

TA 046206

FRAME 2

1. Using 3/4-inch wrenches, unscrew and take off two nuts (1) and two screws (2).
2. Using 15/16-inch wrenches, unscrew and take off two nuts (3). Take out two screws (4 and 5).
3. Take off lifting shackle bracket (6) and brush guard bracket (7).

END OF TASK

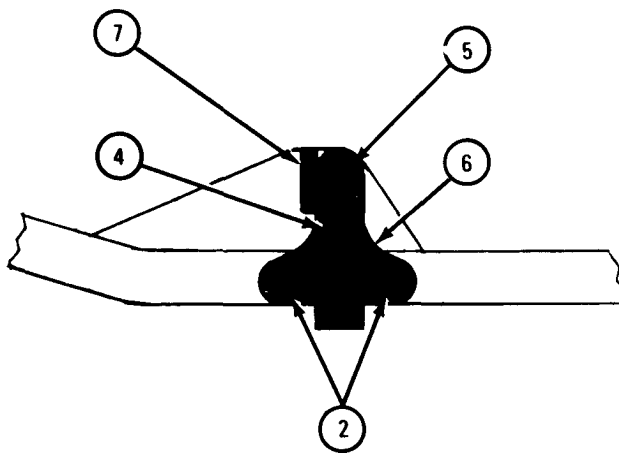

TOP VIEW

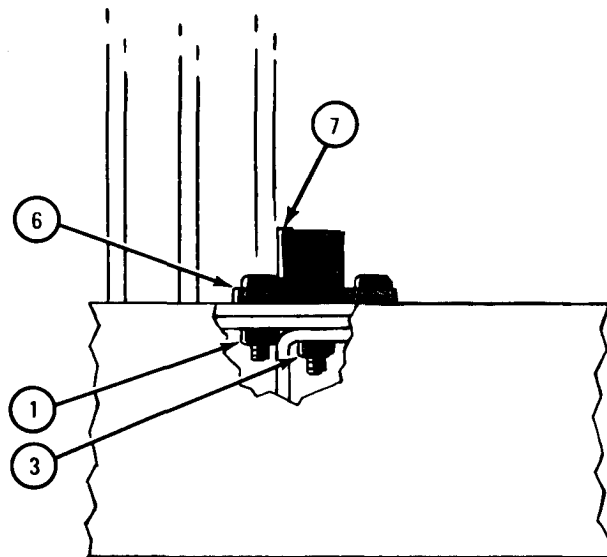

FRONT VIEW

TA 046701

FRAME 3

1. Using 3/4-inch wrenches unscrew and take off two nuts (1), two screws (2), and two spacers (3).
2. Using 15/16-inch wrench unscrew and take off two nuts (4). Take out two screws (5 and 6).
3. Take off shackle bracket (7).

END OF TASK

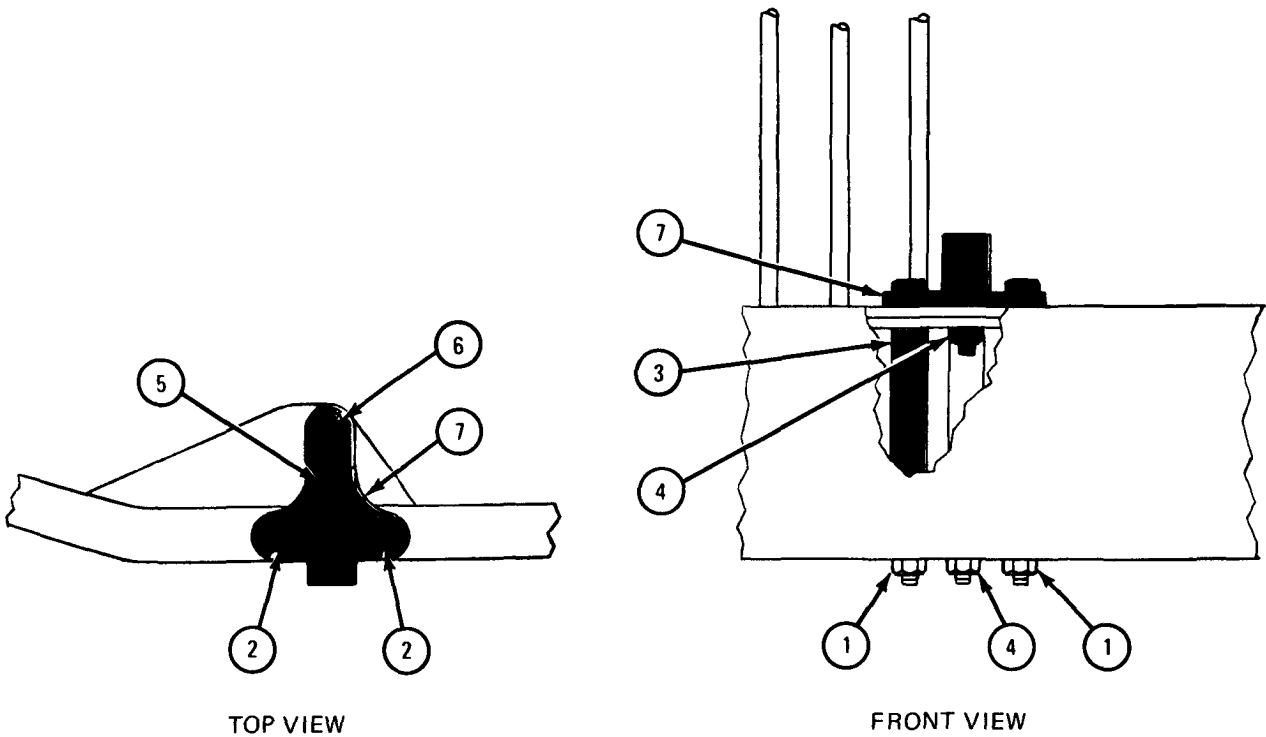

TA 046702

c. Replacement.

FRAME 1

NOTE

For trucks with front winch, go to frame 2. For trucks without front winch, do the following steps.

1. Put brush guard bracket (1) and shackle bracket (2) in place on truck and align holes.
2. Put in two screws (3 and 4).
3. Using 15/16-inch wrenches, screw on and tighten two nuts (5) and two screws (3 and 4).
4. Put in two screws (6).
5. Using 3/4-inch wrenches, screw on and tighten two nuts (7).
6. Replace brush guard. Refer to Part 1, para 6-4.

GO TO FRAME 2

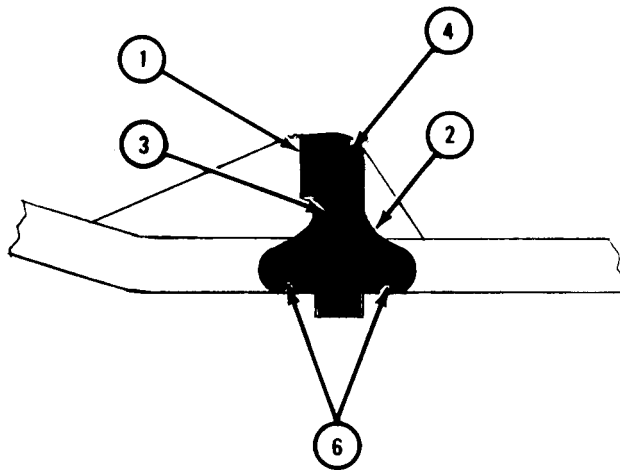
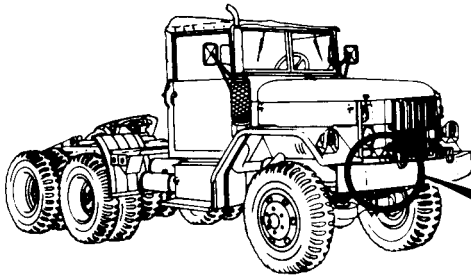

TOP VIEW

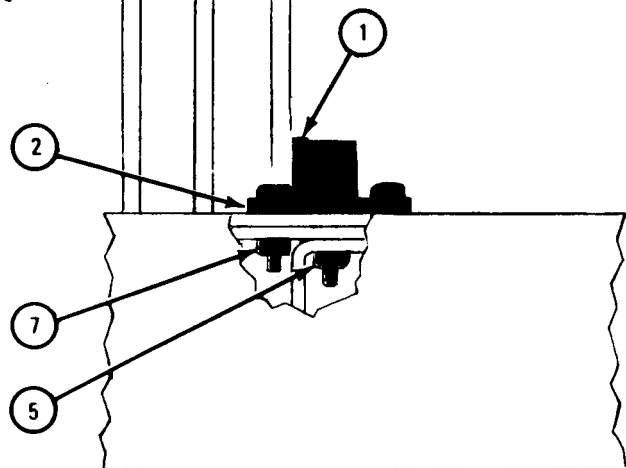

FRONT VIEW

TA 046703

FRAME 2

1. Put lifting shackle bracket (1) in place on truck and aline holes.
2. Put two spacers (2) and two screws (3) in place as shown.
3. Using 3/4-inch wrenches, screw on and tighten two nuts (4).
4. Put two screws (5 and 6) in place.
5. Using 15/16-inch wrenches, screw on and tighten two nuts (7).

GO TO FRAME 3

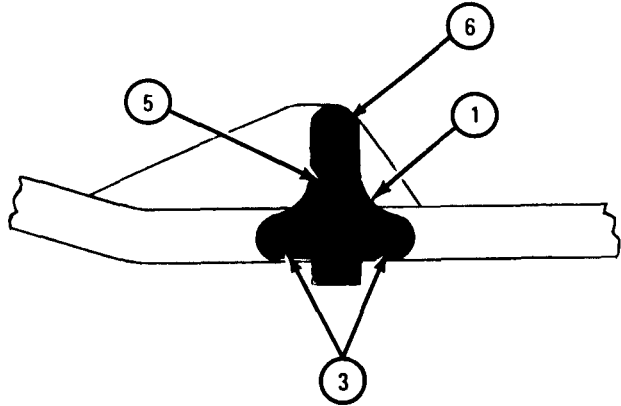
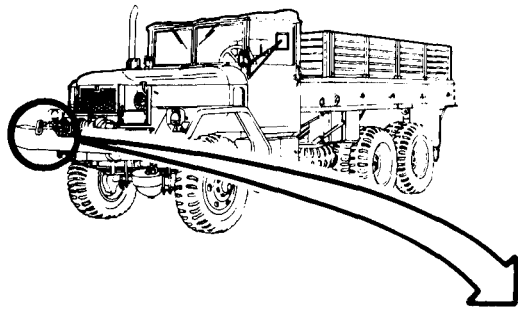

TOP VIEW

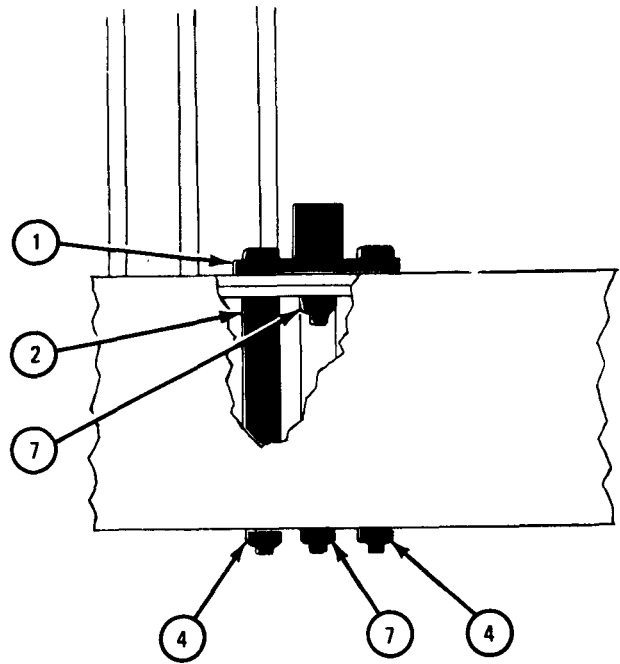

FRONT VIEW

TA 046704

FRAME 3

1. Put lifting shackle (1) in place on lifting shackle bracket (2) and align holes.
2. Put in retaining pin (3). Put clip (4) through hole in retaining pin and snap pin closed.

END OF TASK

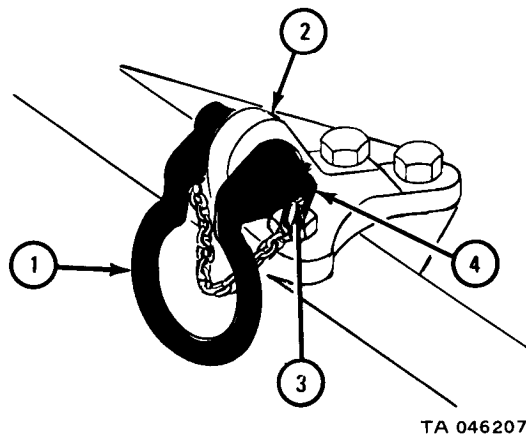

16-4. REAR LIFTING SHACKLE REMOVAL AND REPLACEMENT.

TOOLS: 3/4-inch wrench (2)

SUPPLIES: None

PERSONNEL: One

EQUIPMENT CONDITION: Truck parked, engine off, handbrake set.

a. Removal.

FRAME 1

1. Using wrenches, hold three nuts (1) on front side of rear frame (2) and unscrew and take off three screws (3) and nuts (1).
2. Take off shackle assembly (4).

END OF TASK

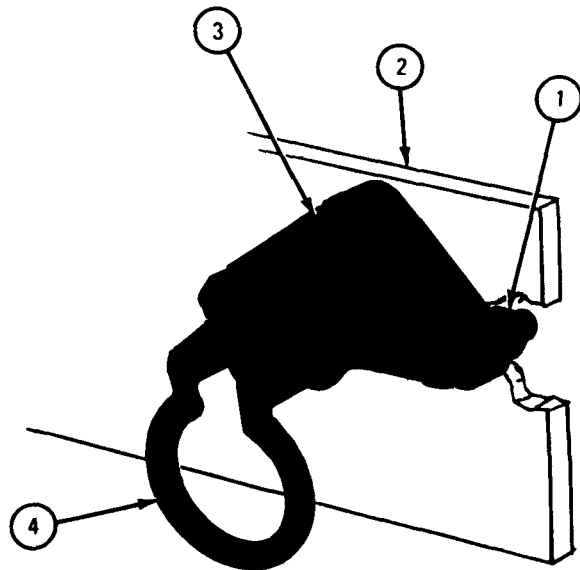
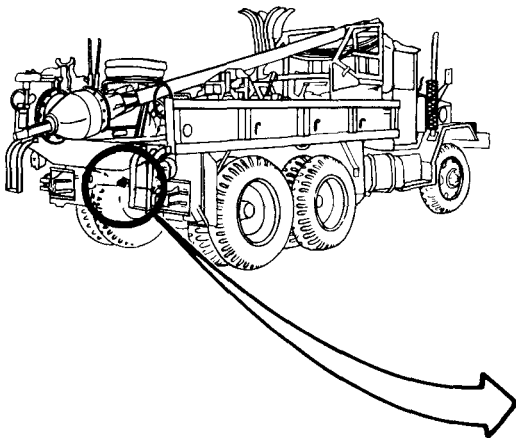

TA 046202

b. Replacement.

FRAME 1

1. Put shackle (1) to rear bumper (2). Line up mounting holes. Put in three screws (3).
2. Using wrenches, put on and hold nuts (4) and screw in and tighten three screws (3).

END OF TASK

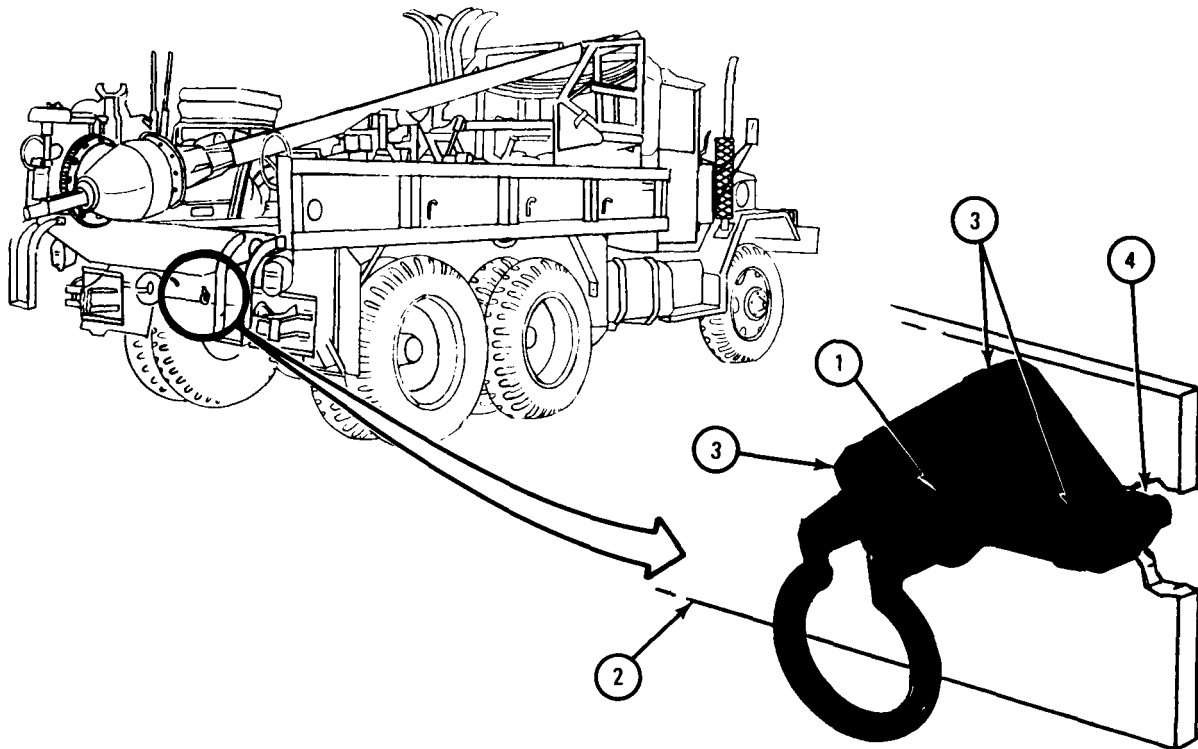

TA 046203

16-5. PINTLE HOOK REMOVAL AND REPLACEMENT.

TOOLS: 8-inch slip joint pliers
Prybar
2 3/16-inch socket wrench

SUPPLIES: None

PERSONNEL: One

EQUIPMENT CONDITION: Truck parked, engine off, handbrake set.

a. Removal.

FRAME 1

1. Using pliers, take out and throw away cotter pin (1).
2. Put prybar (2) through pintle hook (3) to keep pintle hook from turning. Hold prybar.
3. Using 2 3/16-inch wrench, unscrew and take off nut (4). Take off washer (5). Take out prybar (2).
4. Pry pintle hook (3) out of bracket (6).

END OF TASK

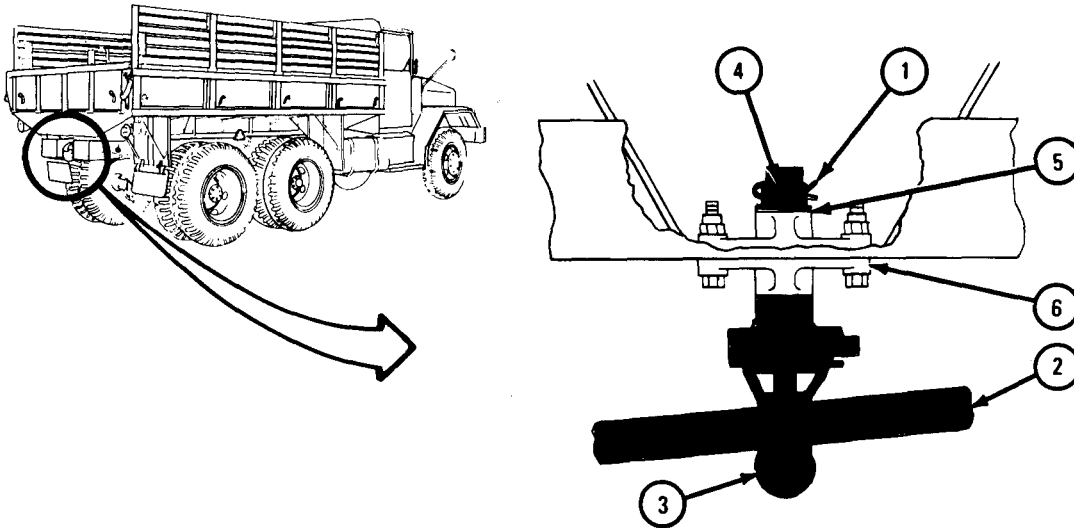

TA 046200

b. Replacement.

FRAME 1

1. Put pintle hook (1) in bracket (2).
2. Put washer (3) in place. Screw on nut (4).
3. Put prybar (5) through pintle hook (1) to keep it from turning. Hold prybar.
4. Using 2 3/16-inch wrench, tighten nut (4) until holes for cotter pin (6) line up. Take out prybar (5).
5. Put cotter pin (6) in place. Using pliers, bend open ends of cotter pin.

END OF TASK

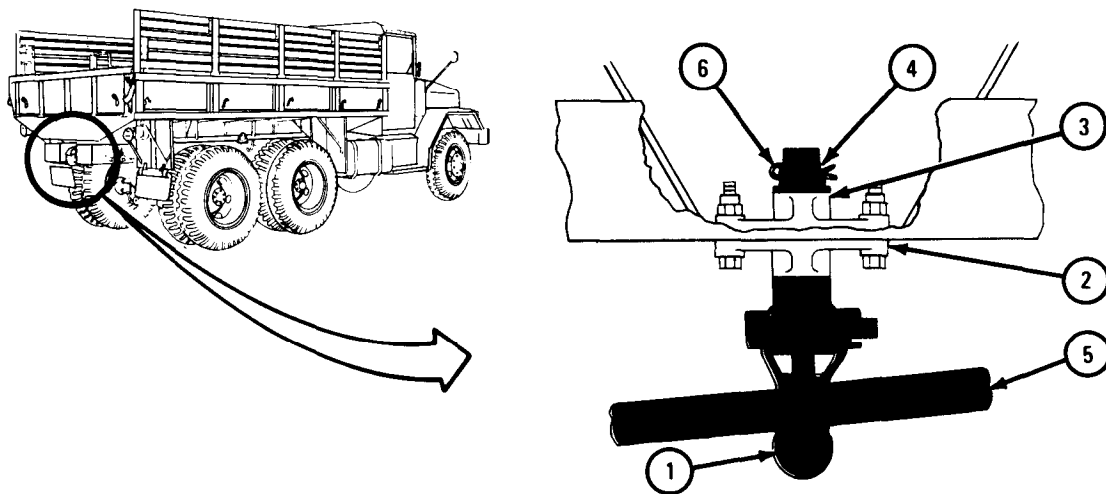

TA 046201

16-6. PINTLE HOOK REPAIR.

TOOLS: Pliers
1 1/2-inch wrench (2)
Drift punch
Hammer
Center punch
Anvil
Vise

SUPPLIES: Solvent, dry cleaning, type II (SD-2),
Fed. Spec P-D-680
Artillery and automotive grease, type GAA, MIL-G-10924

PERSONNEL: Two

EQUIPMENT CONDITION: Truck parked, engine off, handbrake set.

- a. Preliminary Procedure. Take pintle hook off truck. Refer to para 16-5.
- b. Disassembly.

FRAME 1

1. Put pintle hook (1) in vise.
2. Using pliers, take out cotter pin (2).
3. Using wrenches, hold bolt (3) and unscrew and take off nut (4). Take out bolt.
4. Take pintle hook (1) out of vise and put latch (5) into vise.
5. Using hammer, tap off lock (6) from pintle hook (1).
6. Using hammer and drift punch, drive out pin (7).
7. Take lock (6) off latch (5). Spring (8) will stay on latch. Take off spring.
8. Take latch (5) out of vise.

IF WORKING ON PINTLE WITH TEFLON BUSHINGS, GO TO FRAME 2.
IF WORKING ON PINTLE WITH GREASE FITTING, END OF TASK

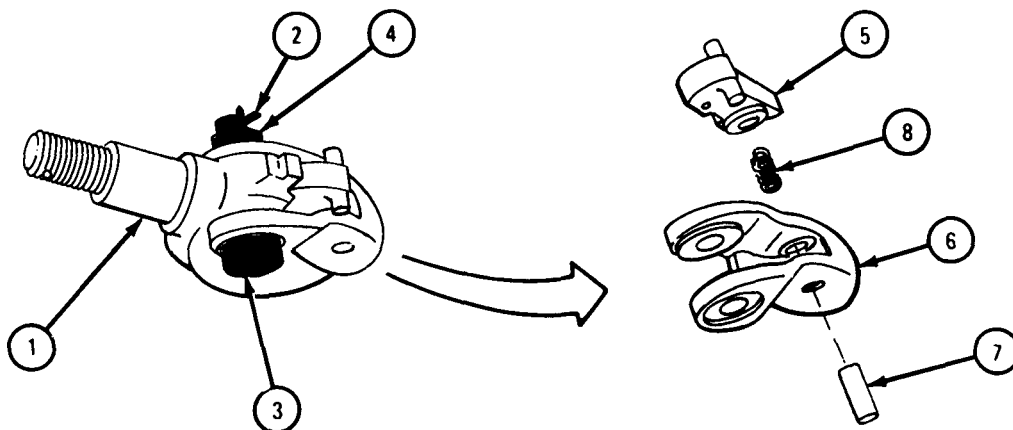

TA 046204

FRAME 2

1. Place pintle latch (1) in vise (2) with bushings (3) clear of vise jaws (4).
2. Ream bushings (3) to 0.779 to 0.782 inch inside diameter.
3. Take pintle latch (1) out of vise (2).

GO TO FRAME 3

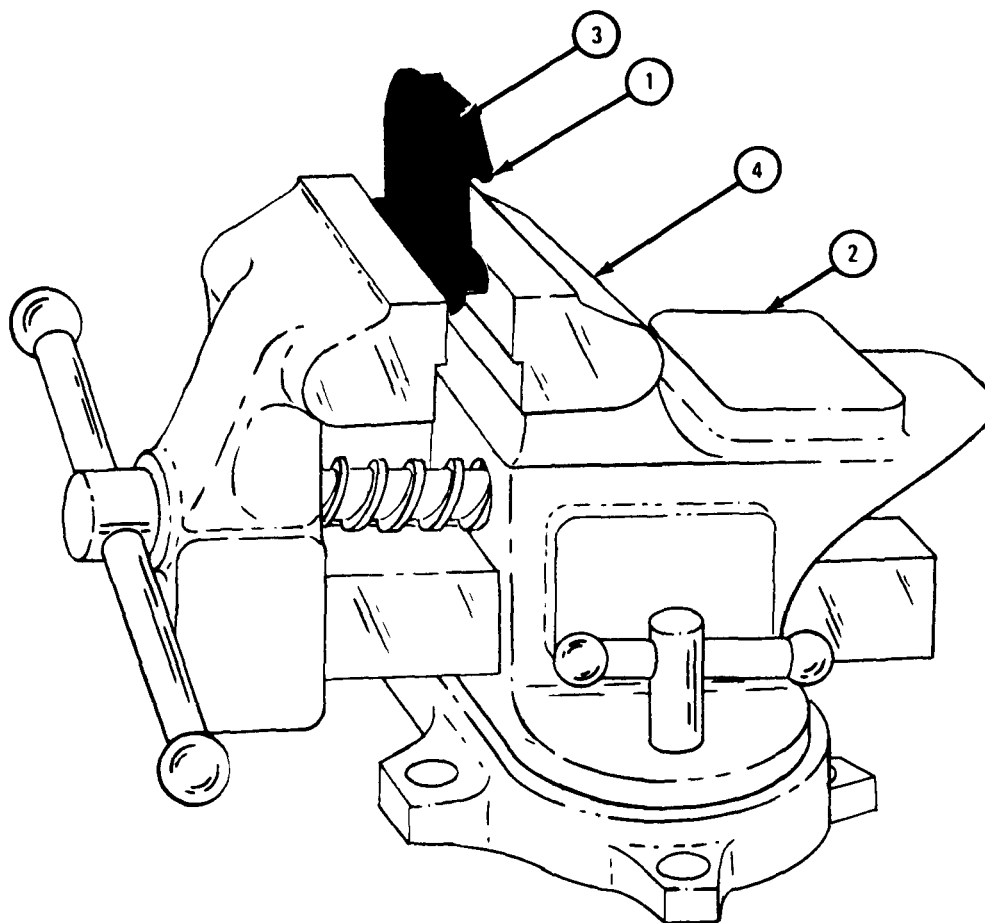

TA 104740

FRAME 3

1. Place pintle hook (1) in vise (2) with bushings (3) clear of jaws (4).
2. Ream bushings (3) to 1.028 to 1.032 inches inside diameter.
3. Take pintle hook (1) out of vise (2).

END OF TASK

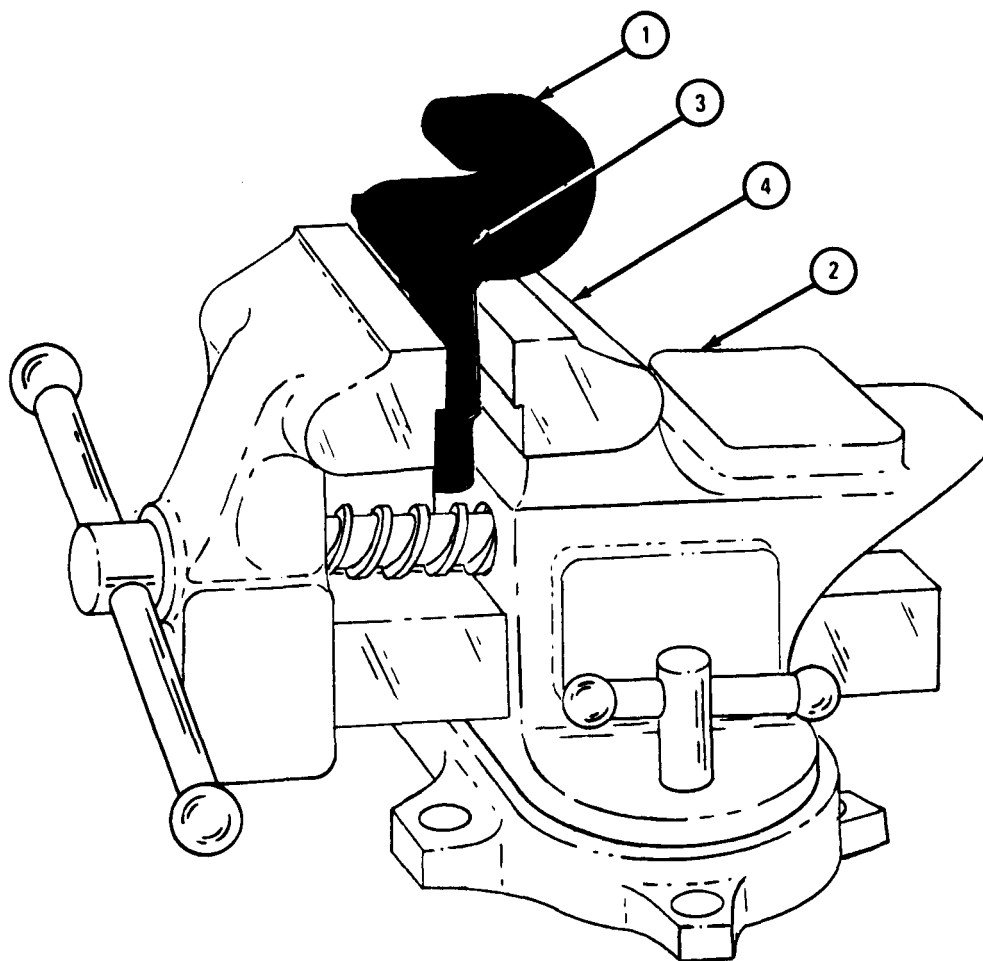

TA 104741

c. Assembly.

FRAME 1

WARNING

Dry cleaning solvent is flammable. Do not use near an open flame. Keep a fire extinguisher nearby when solvent is used. Use only in well-ventilated places. Failure to do this may result in injury to personnel and damage to equipment.

1. Look over all parts. Throw away any damaged parts and get new parts in their place. Clean all parts in solvent before putting them together.
2. Put pintle hook (1) into vise.
3. Put lock (2) on pintle hook (1) and line up bolt holes. Put bolt (3) through lock. Using wrenches, hold bolt (3) and screw on nut (4) until cotter pin holes line up.
4. Put cotter pin (5) through bolt (3). Using pliers, bend cotter pin ends around nut (4).
5. Put spring (6) in lock (2). Put latch (7) into lock (2) and push down until pin holes line up. Push pin (8) into lock (2).

GO TO FRAME 2

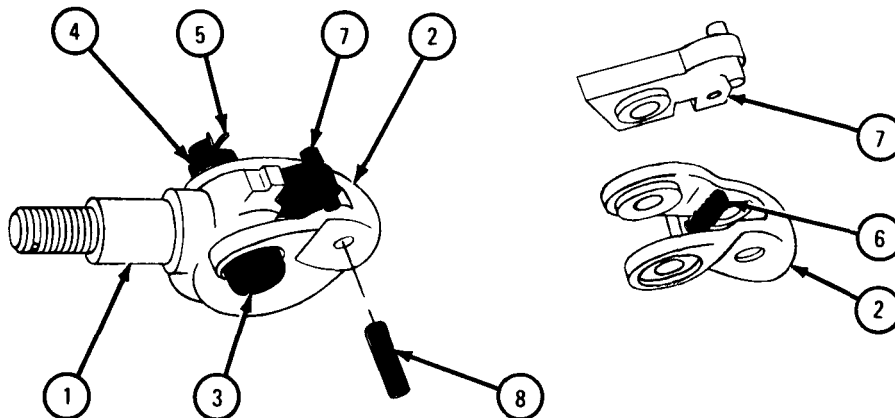

TA 046205

FRAME 2

1. Put pintle hook (1) on anvil (2) so part around pin (3) is flat on anvil.
2. Using center punch and hammer, stake pin (3) in three places (4).
3. Turn pintle hook (1) over so other side is flat on anvil (2). Using center punch and hammer, stake pin (3) in three places (4).

NOTE

Follow-on Maintenance Action Required:

1. Put pintle hook on truck. Refer to para 16-5.
2. Lubricate pintle hook. Refer to LO 9-2320-209-12/1.

END OF TASK

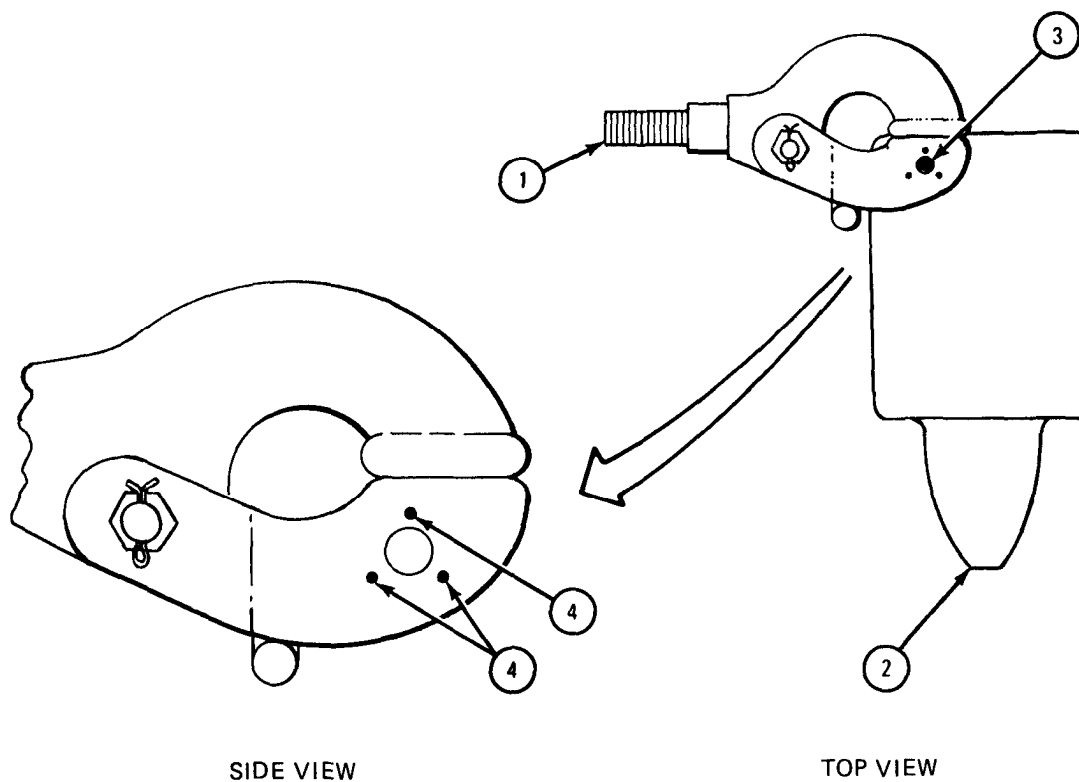

TA 046269

Section III. SPARE WHEEL CARRIER

16-7. SPARE WHEEL CARRIER REMOVAL AND REPLACEMENT (ALL TRUCKS EXCEPT TRUCK M342A2).

TOOLS: 3/4-inch wrench (2)

SUPPLIES: None

PERSONNEL: One

EQUIPMENT CONDITION: Truck parked, engine off, handbrake set.

a. Preliminary Procedures.

(1) Remove spare wheel from carrier. Refer to TM 9-2320-209-10.

(2) Remove air reservoir.

(a) On trucks M275A1 and M275A2, refer to para 13-26.

(b) On truck M35A1, refer to para 13-30.

(c) On truck M764, refer to para 13-29.

(d) On trucks M35A2C, M50A2, M109A3, M185A3, and M756A2, refer to para 13-28.

(e) On trucks M49A1C and M49A2C, refer to para 13-27.

b. Removal.

FRAME 1

1. Using wrenches, hold four screws (1) and unscrew and take off four nuts (2).
2. Take off spare wheel carrier (3). Take out four screws (1).

END OF TASK

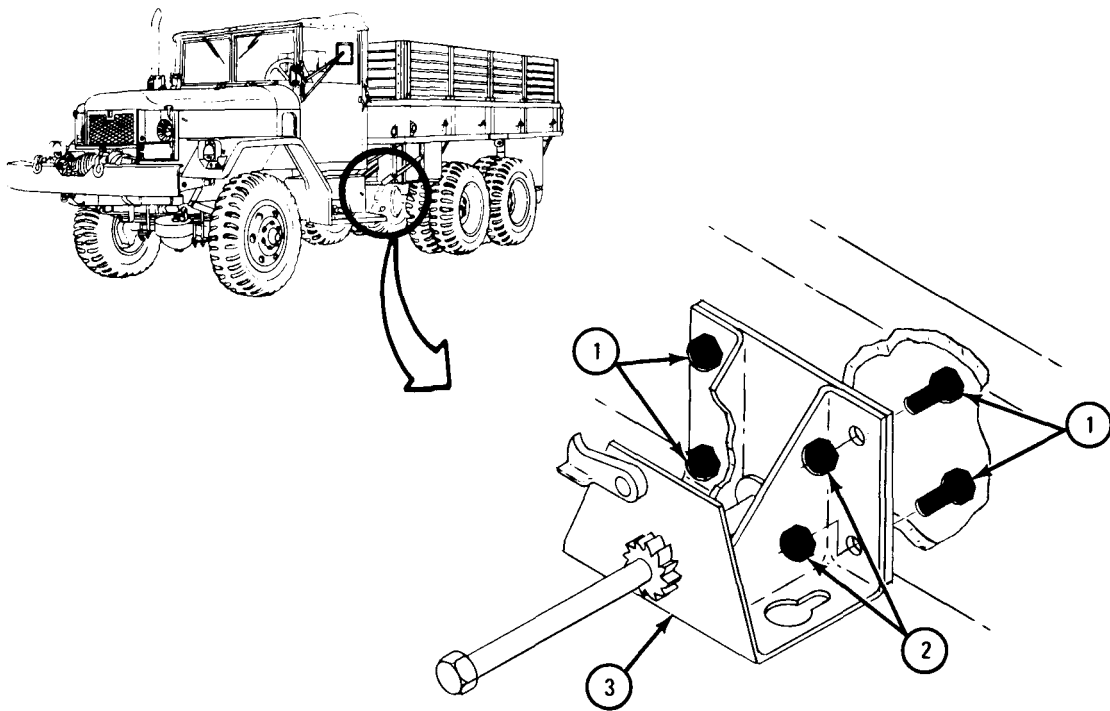

TA 046383

c. Replacement.

FRAME 1

1. Put screw (1) through truck frame from inside. Put spare wheel carrier (2) on screw and start nut (3).
2. Put three screws (4) through truck frame and spare wheel carrier (2). Start three nuts (5) on screws.
3. Using wrench, hold four screws (1 and 4). Using wrench, tighten four nuts (3 and 5).

NOTE

Follow-on Maintenance Action Required:

1. Replace air reservoir.
 - (a) On trucks M275A1 and M275A2, refer to para 13-26.
 - (b) On truck M35A1, refer to para 13-30.
 - (c) On truck M764, refer to para 13-29.
 - (d) On trucks M35A2C, M50A2, M109A3, M185A3, and M765A2, refer to para 13-28.
 - (e) On trucks M49A1C and M49A2C, refer to para 13-27.
2. Put spare wheel in carrier. Refer to TM 9-2320-209-10.

END OF TASK

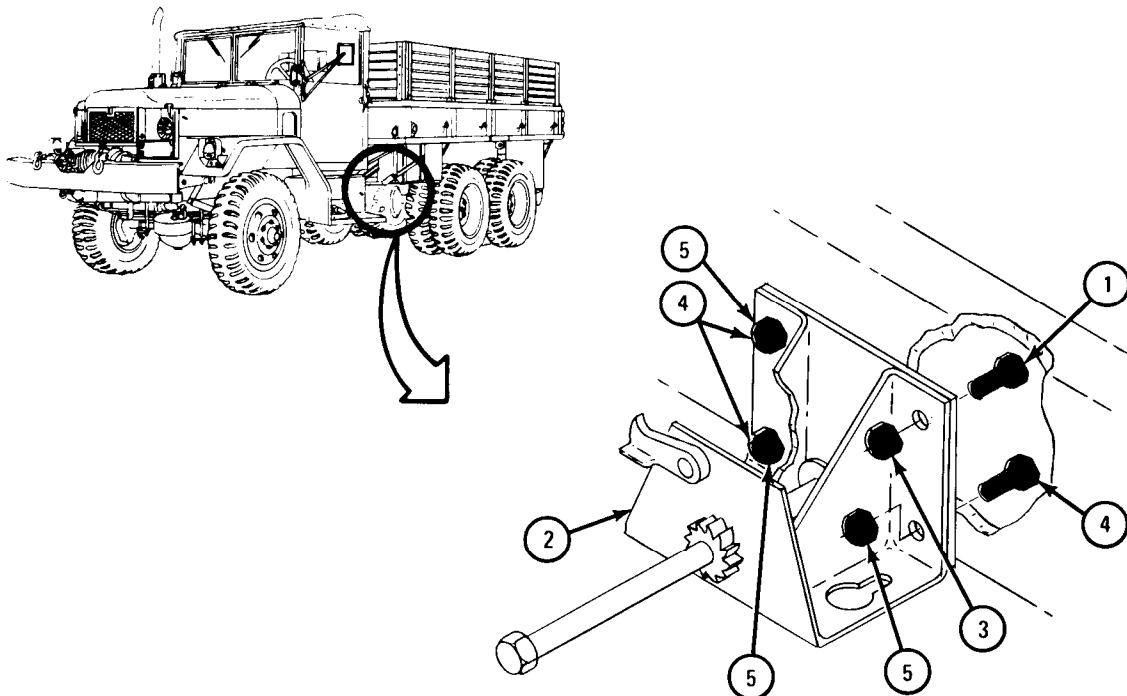

TA 046384

16-8. SPARE WHEEL CARRIER REPAIR (ALL TRUCKS EXCEPT TRUCK M342A2).

TOOLS: 7/16-inch wrench
Pliers
Leather gloves

SUPPLIES: None

PERSONNEL: One

EQUIPMENT CONDITION: Truck parked, engine off, handbrake set.

NOTE

Repair of spare wheel carrier is limited to replacement of damaged parts.

a. Preliminary Procedure. Remove spare wheel carrier from truck. Refer to para 16-7.

b. Disassembly.

FRAME 1

1. Turn pick-up member (1) with cable (2) attached so nuts (3) are facing up.
2. Using 7/16-inch wrench, unscrew and take off four nuts (3), four lockwashers (4), and two U-bolts (5).

WARNING

Always wear leather gloves when handling cable. Do not let cable run through hands. Broken or rusty wires can cause serious injury to personnel.

3. Pull ends of cable (2) out of holes in pick-up member (1).

GO TO FRAME 2

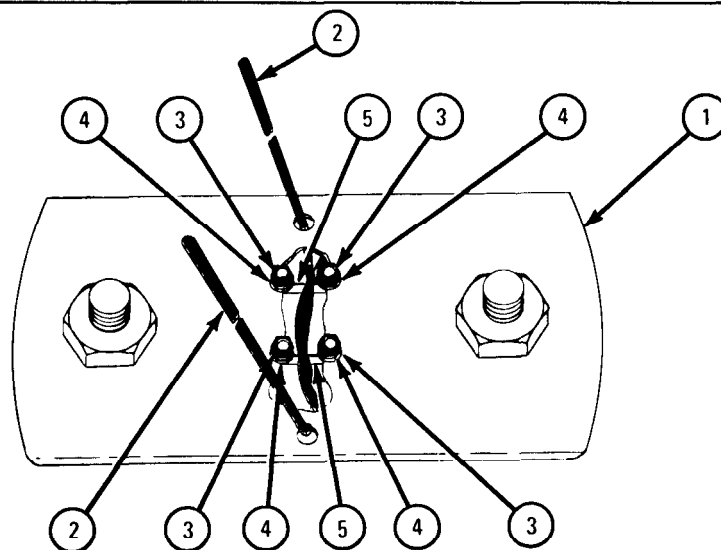

TA 046385

FRAME 2

WARNING

Be careful to avoid injury. If cable is frayed, sharp ends can go through leather glove and cause injury.

1. Using leather-gloved hand, pull loose ends of cable (1) up and out of opening (2) in housing (3).
2. Lift up and hold pawl (4). Using leather-gloved hand, pull on cable (1) until it is unwound from shaft (5).

GO TO FRAME 3

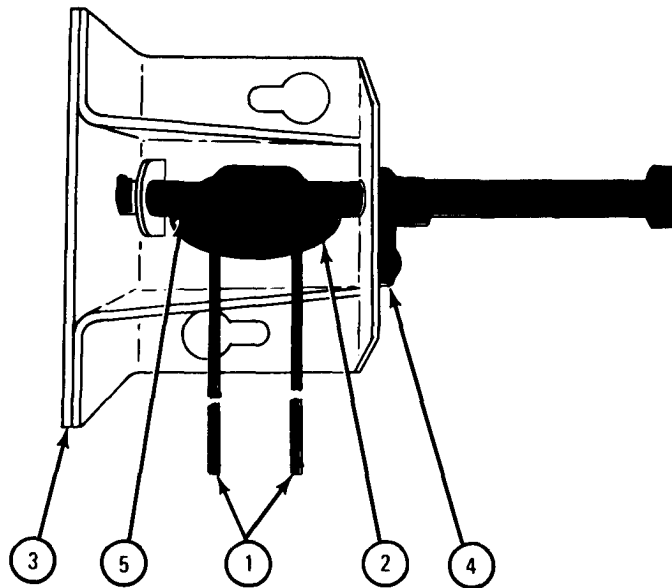

TA 046386

FRAME 3

1. Using pliers, pull cable (1) out of holes in shaft (2). Take off cable.
2. Using pliers, take out and throw away cotter pin (3).
3. Take shaft (2) out of housing (4).

END OF TASK

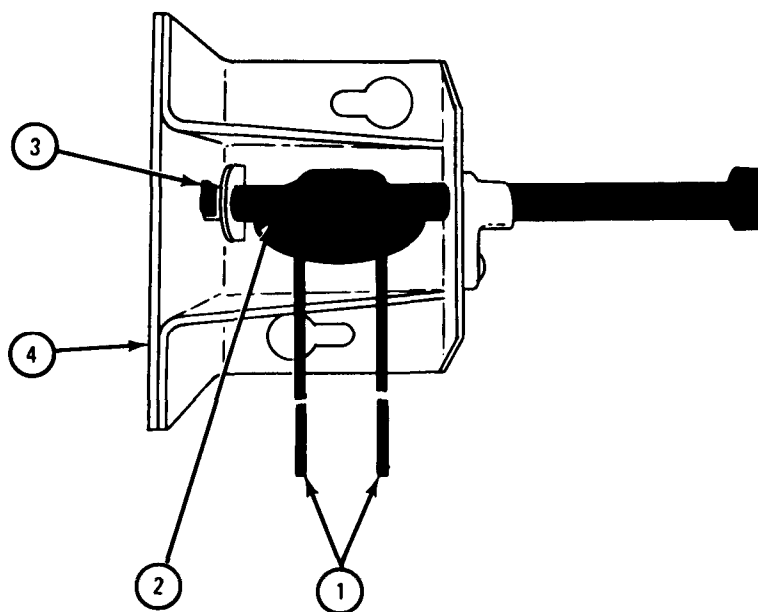

TA 046387

c. Assembly.**FRAME 1**

1. Check all parts. Throw away any damaged parts and put new parts in their place.
2. Lift up and hold pawl (1) out of the way. Put shaft (2) through housing (3) and bracket (4). Let go of pawl.
3. Put cotter pin (5) through hole in end of shaft (2). Using pliers, bend open ends of cotter pin.

WARNING

Always wear leather gloves when handling cable. Do not let cable run through hands. Broken or rusty wires can cause serious injury to personnel.

4. Put one end of cable (6) through each hole in shaft (2). Hold both ends of cable together so they are even when pulled. Pull them until they are through shaft.
5. Put both ends of cable (6) down through opening (7) in bottom of housing (3).

GO TO FRAME 2

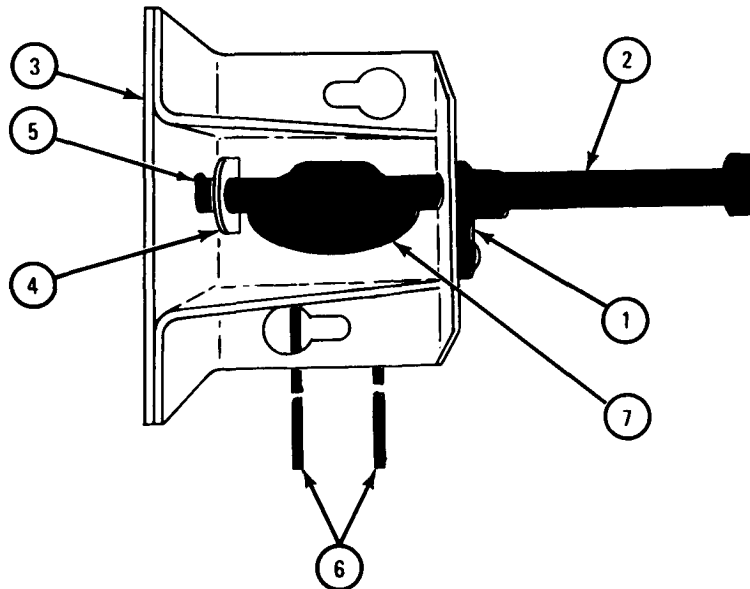

TA 046388

FRAME 2

1. Put ends of cable (1) through holes in pickup member (2) on side where nuts (3) are. Twist cables around each other for almost the width of the pickup member.
2. Put U-bolts (4) through holes in pickup member (2) so cables (1) are caught.
3. Put lockwashers (5) on two U-bolts (4). Using wrench, screw on and tighten nuts (6).

NOTE

Follow-on Maintenance Action Required:

Put spare wheel carrier back on truck. Refer to para 16-7.

END OF TASK

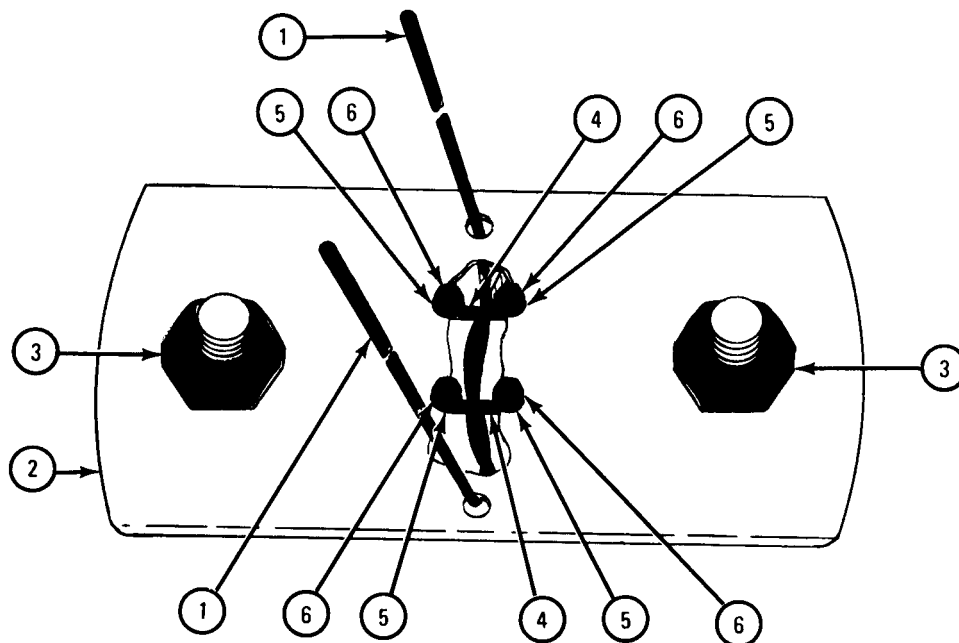

TA 046389

16-9. SPARE WHEEL CARRIER REMOVAL AND REPLACEMENT (TRUCK M342A2).

TOOLS: 9/16-inch box wrench
 9/16-inch socket wrench
 Pry bar

SUPPLIES: None

PERSONNEL: Two

EQUIPMENT CONDITION: Truck parked, engine off, handbrake set.

a. Preliminary Procedure. Remove spare wheel from wheel carrier. Refer to TM 9-2320-209-10.

b. Removal.

FRAME 1

1. Open tool box (1). Using 9/16-inch wrench, unscrew and take off six screws (2) and four nuts (3).

2. Take off tool box (1) and two spacers (4).

GO TO FRAME 2

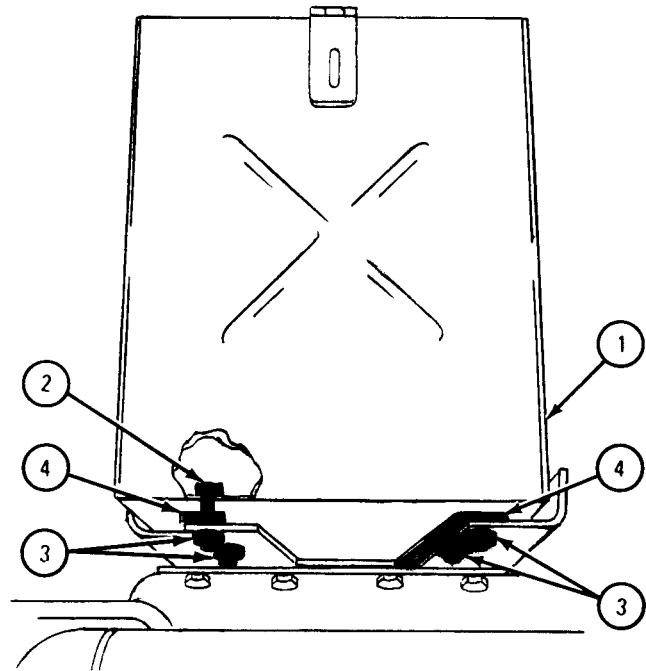
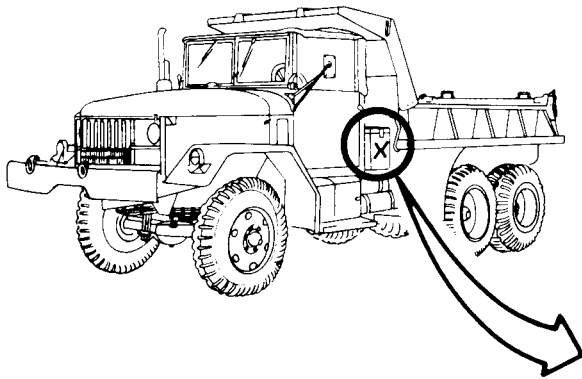

TA 046419

FRAME 2

1. Using 9/16-inch wrench, unscrew and take off four nuts (1) and screws (2).
2. Go to other side of truck. You will be working on other end of spare wheel carrier.

GO TO FRAME 3

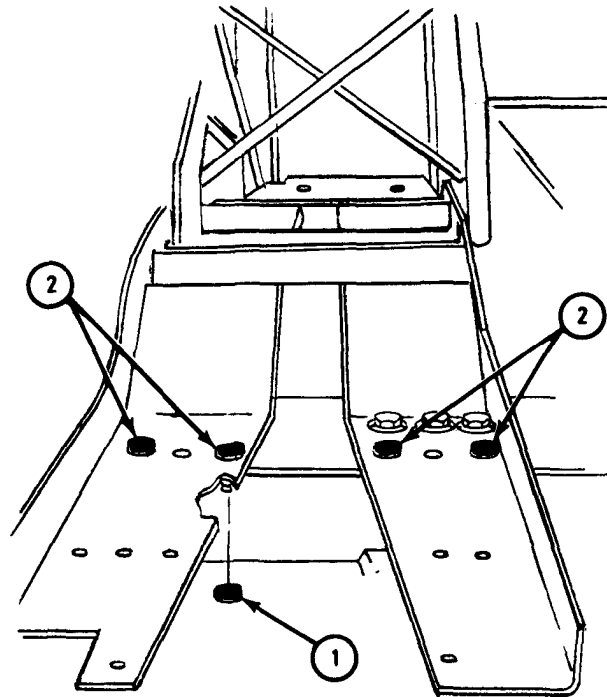

TA 046420

FRAME 3

Soldier A 1. Using 9/16-inch wrench, loosen four screws (1).

Soldier B 2. Using prybar (2), raise back end of cab (3).

Soldier A 3. Take out four screws (1).

Soldier B 4. Let back end of cab (3) down and take out prybar (2).

GO TO FRAME 4

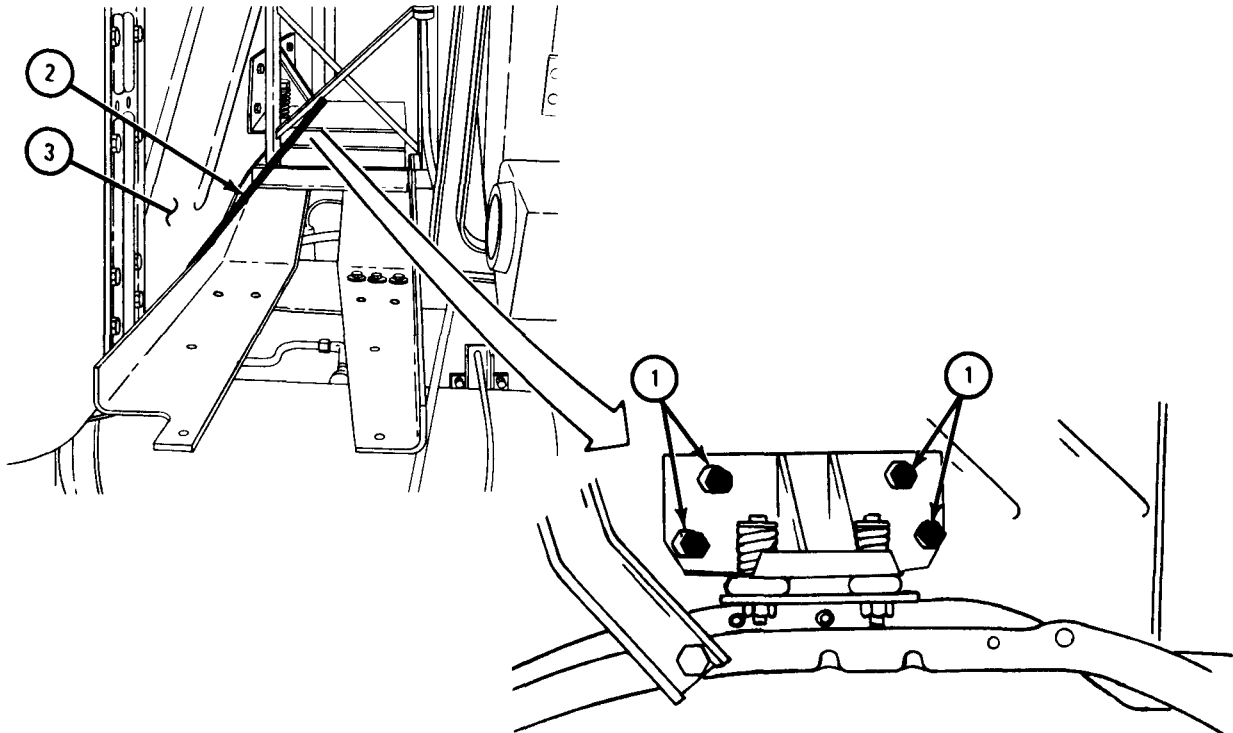

TA 046421

FRAME 4

1. Using 9/16-inch wrench, unscrew and take off four nuts (1) and screws (2).
2. Take off spare wheel carrier (3).

END OF TASK

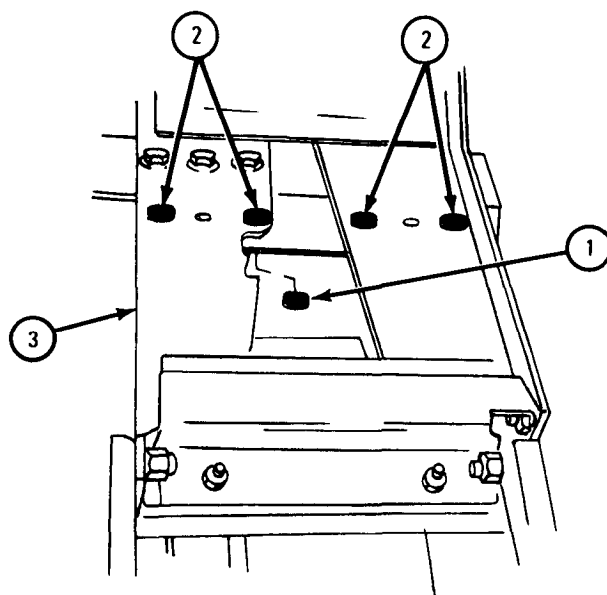

TA 046422

c. Replacement.

FRAME 1

- Soldier A 1. Put spare wheel carrier (1) into place behind cab (2) of truck.
- Soldier B 2. Using prybar (3), raise up cab (2) to aline four screw holes in back of cab with four screw holes in mounting bracket (4).
- Soldier A 3. Using 9/16-inch wrench, screw in and tighten four screws (5).
- Soldier B 4. Let back of cab (2) down and take out prybar (3).
- GO TO FRAME 2

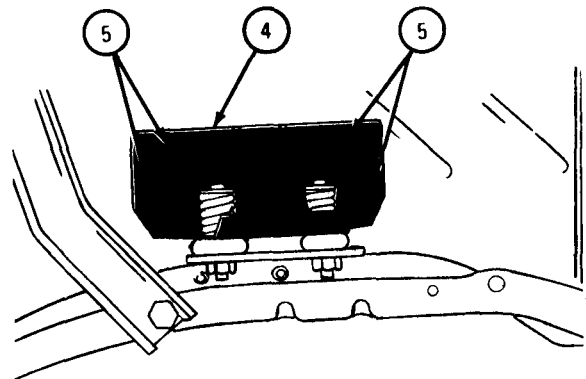
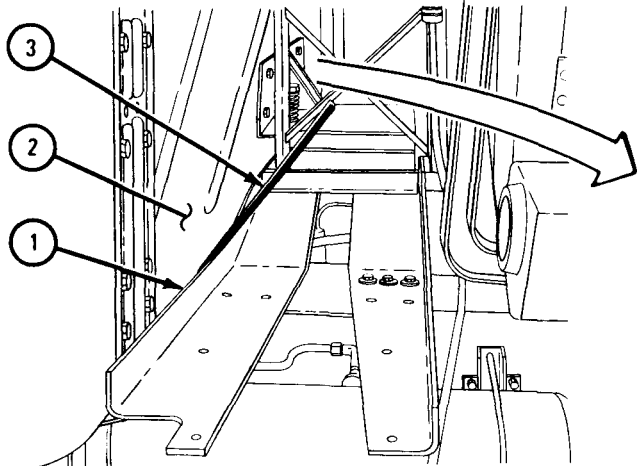
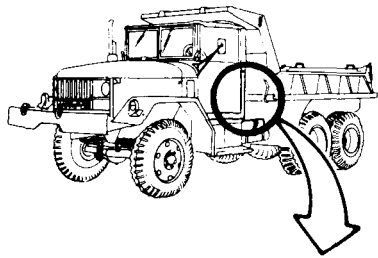

TA 046423

FRAME 2

1. Put four screws (1) through spare wheel carrier (2) and bracket (3).
2. Using 9/16-inch wrench, hold four nuts (4). Using 9/16-inch wrench, tighten four screws (1) until almost tight. Spare wheel carrier must be free to slide.
3. Go to driver's side of truck. You will be working on other end of spare wheel carrier.

GO TO FRAME 3

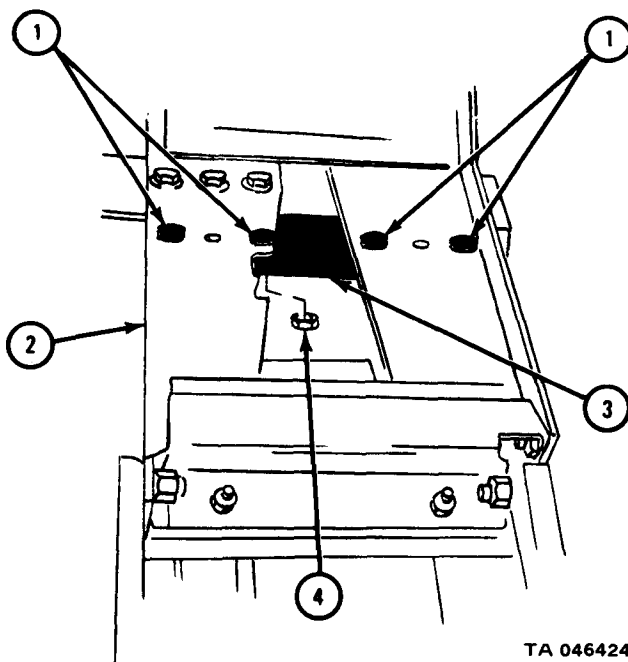

FRAME 3

1. Put four screws (1) through spare wheel carrier (2) and bracket (3).
2. Using 9/16-inch wrench, hold four nuts (4). Using 9/16-inch wrench, screw in and tighten four screws (1).

GO TO FRAME 4

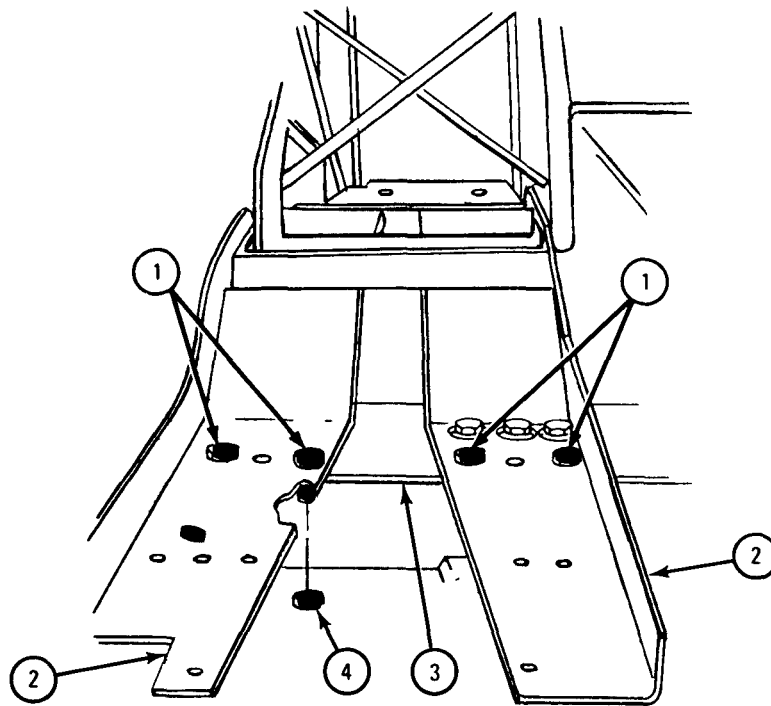

TA 046425

FRAME 4

1. Put two spacers (1) onto spare wheel carrier (2). Line up screw holes.
2. Open tool box (3). Set tool box down on spacers (1). Line up screw holes.
3. Put six screws (4) down through holes in tool box (3) and through spacers (1) and spare wheel carrier (2).
4. Using 9/16-inch wrench, hold screws (4). Using 9/16-inch wrench, screw on and tighten four nuts (5).

GO TO FRAME 5

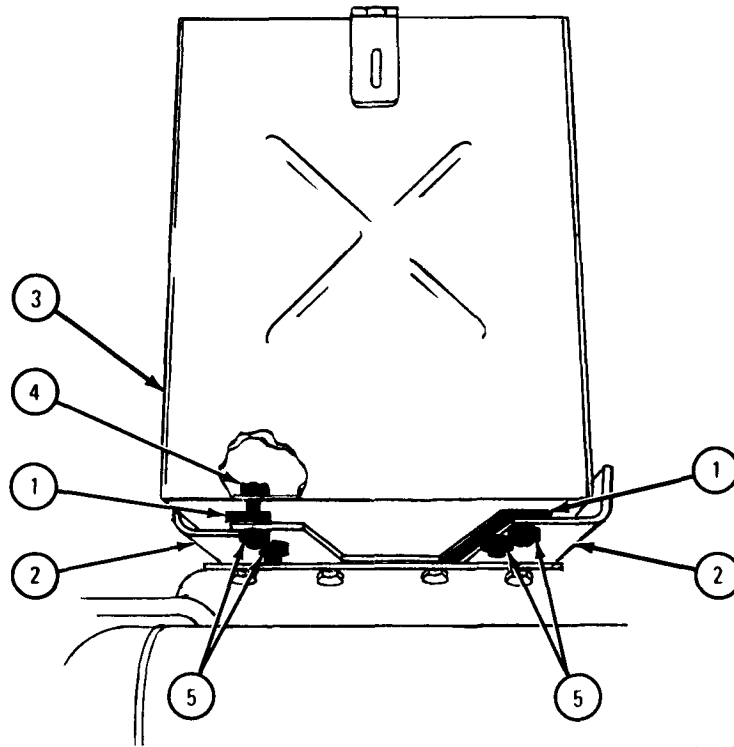

TA 046426

FRAME 5

1. Go to other side of truck. You will be working on other end of spare wheel carrier.
2. Using 9/16-inch wrench, hold four nuts (1). Using 9/16-inch wrench, tighten four screws (2).

NOTE

Follow-on Maintenance Action Required:

Put spare wheel in spare wheel carrier. Refer to
TM 9-2320-209-10.

END OF TASK

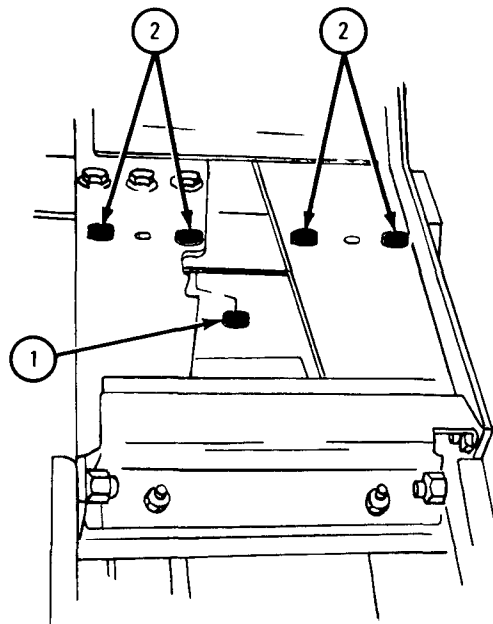

TA 046427

16-10. SPARE WHEEL CARRIER REPAIR (TRUCK M342A2).

TOOLS: Pliers
1/2-inch wrench
15/16-inch wrench
9/16-inch wrench
15/16-inch tubing wrench
Prybar

SUPPLIES: Wood block,
2 x 4 x 24 inches

PERSONNEL: One

EQUIPMENT CONDITION: Truck parked, engine off, handbrake set.

a. Preliminary Procedure. Remove spare wheel carrier from truck. Refer to para 16-9.

b. Disassembly.

FRAME 1

1. Using 9/16-inch wrenches, unscrew and take out four nuts (1) and screws (2) and take out spacer (3).

2. Do step 1 again for spacer (4).

GO TO FRAME 2

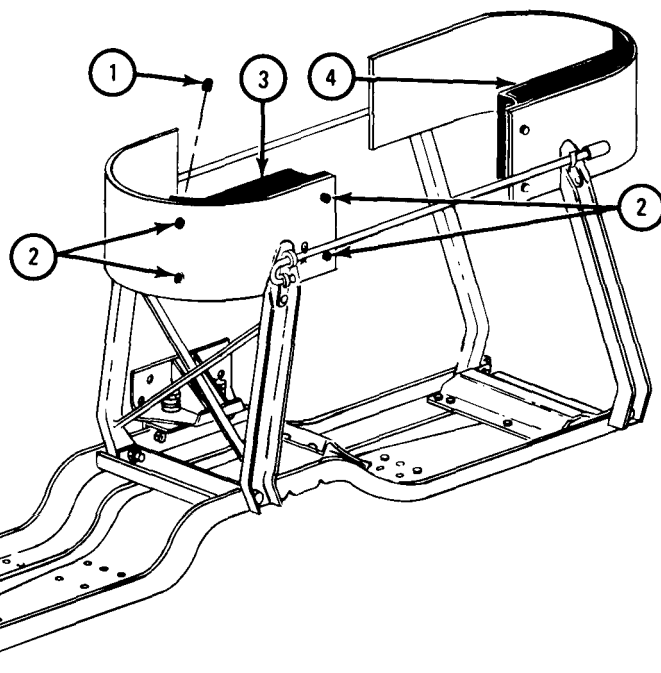
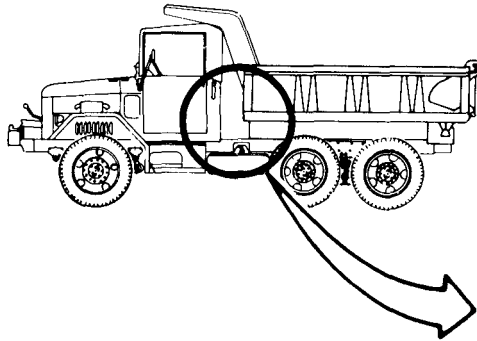

TA 046517

FRAME 2

1. Using pliers, take out and throw away cotter pin (1).
2. Unscrew sleeve nut (2).
3. Pull out hook bolt (3).
4. Do steps 1, 2, and 3 again for hook bolt (4).

GO TO FRAME 3

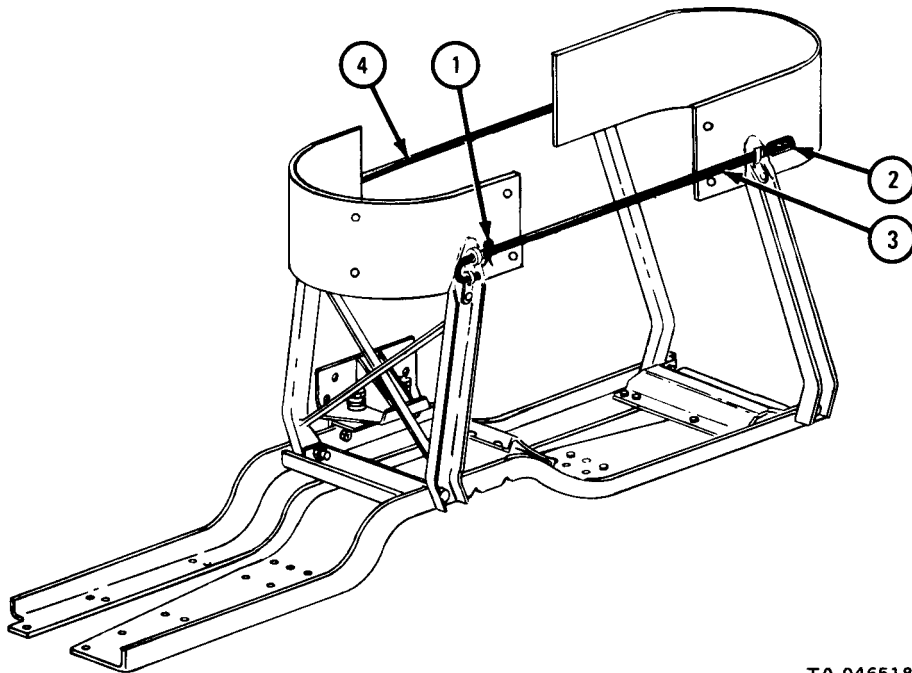

TA 046518

FRAME 3

1. Using 15/16-inch tubing wrench and 15/16-inch wrench, unscrew and take out two nuts (1) and screws (2). Take away bar assembly (3).
2. Do step 1 again for bar assembly (4).

GO TO FRAME 4

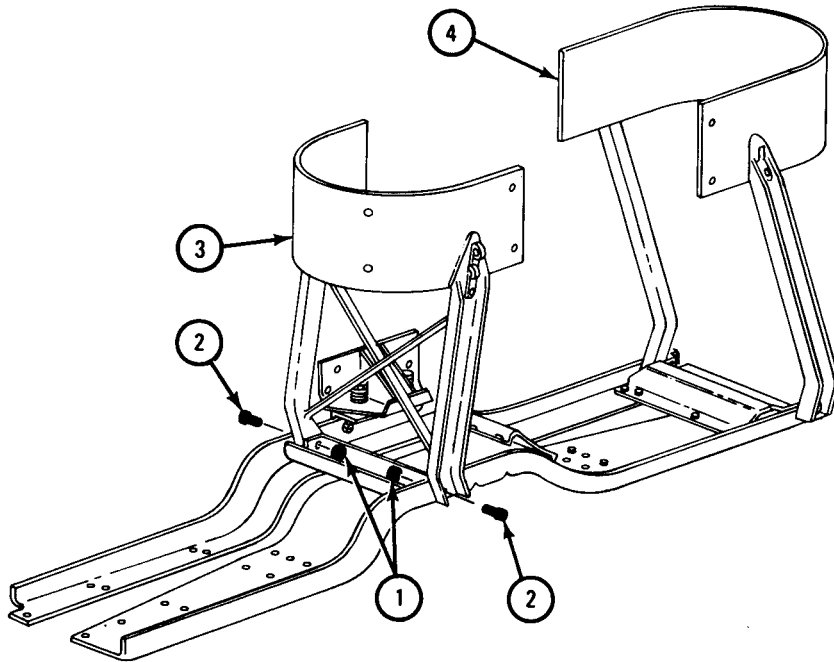

TA 046519

FRAME 4

1. Using 15/16-inch wrenches, unscrew and take out nut (1) and screw (2).
2. Take off three washers (3) and spring (4).
3. Using prybar, raise back of cab (5) and place wood block between cab and frame (6).
4. Take off rubber mount (7).
5. Do steps 1, 2, and 3 again and take off rubber mount (8).

GO TO FRAME 5

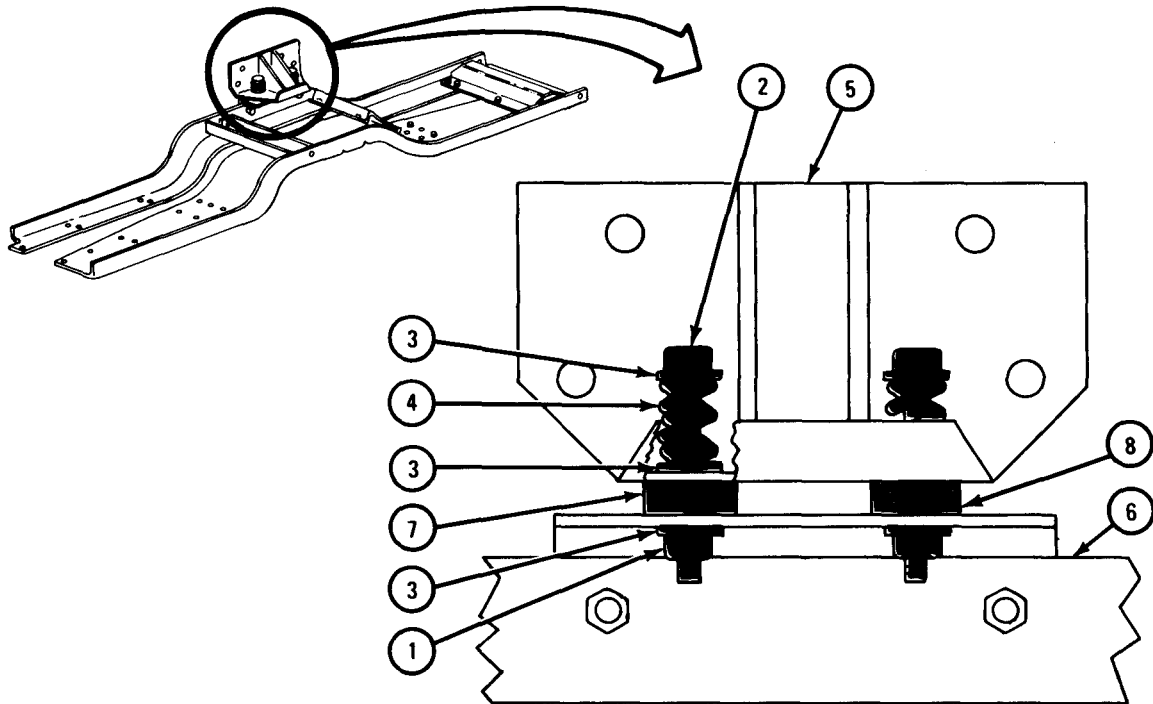

TA 046520

FRAME 5

1. Using 9/16-inch wrenches, unscrew and take out four nuts (1) and screws (2).
2. Using 9/16-inch wrenches, unscrew and take out two nuts (3), two screws (4), and bracket (5). Take off support (6).

GO TO FRAME 6

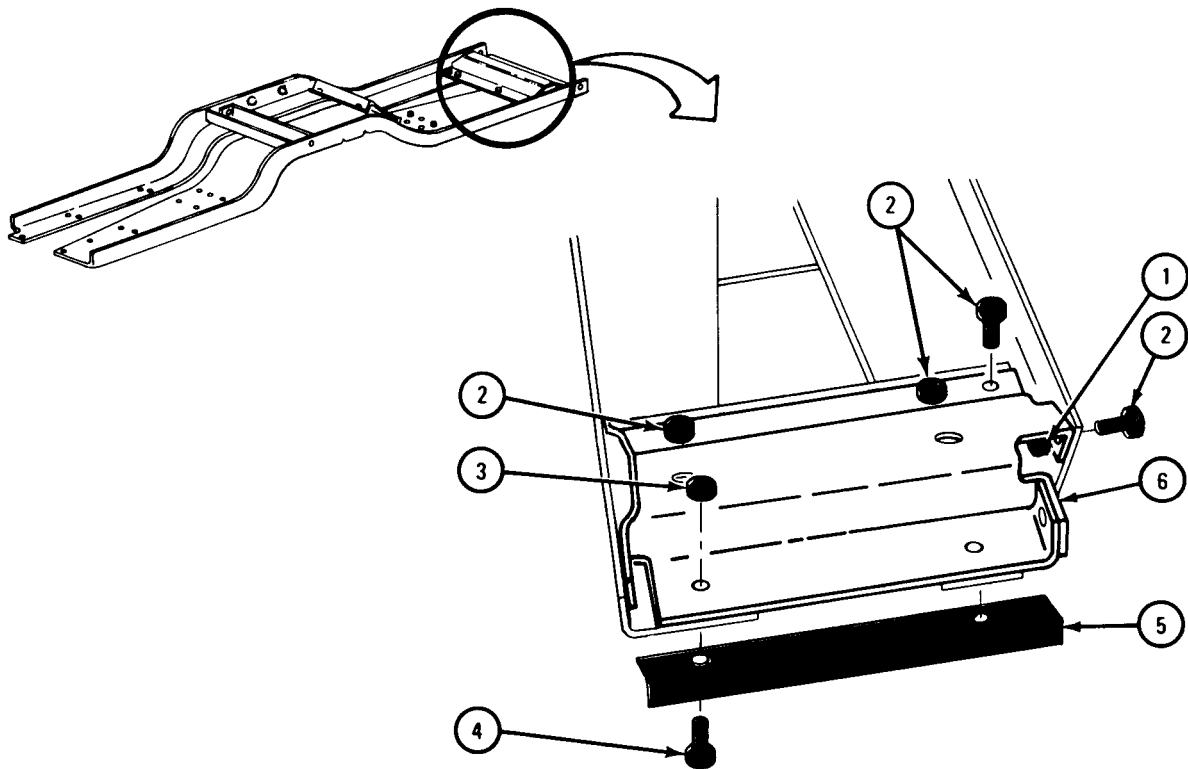

TA 046522

FRAME 6

1. Using 9/16-inch wrenches, unscrew and take out four nuts (1) and screws (2).
2. Take off support (3).

GO TO FRAME 7

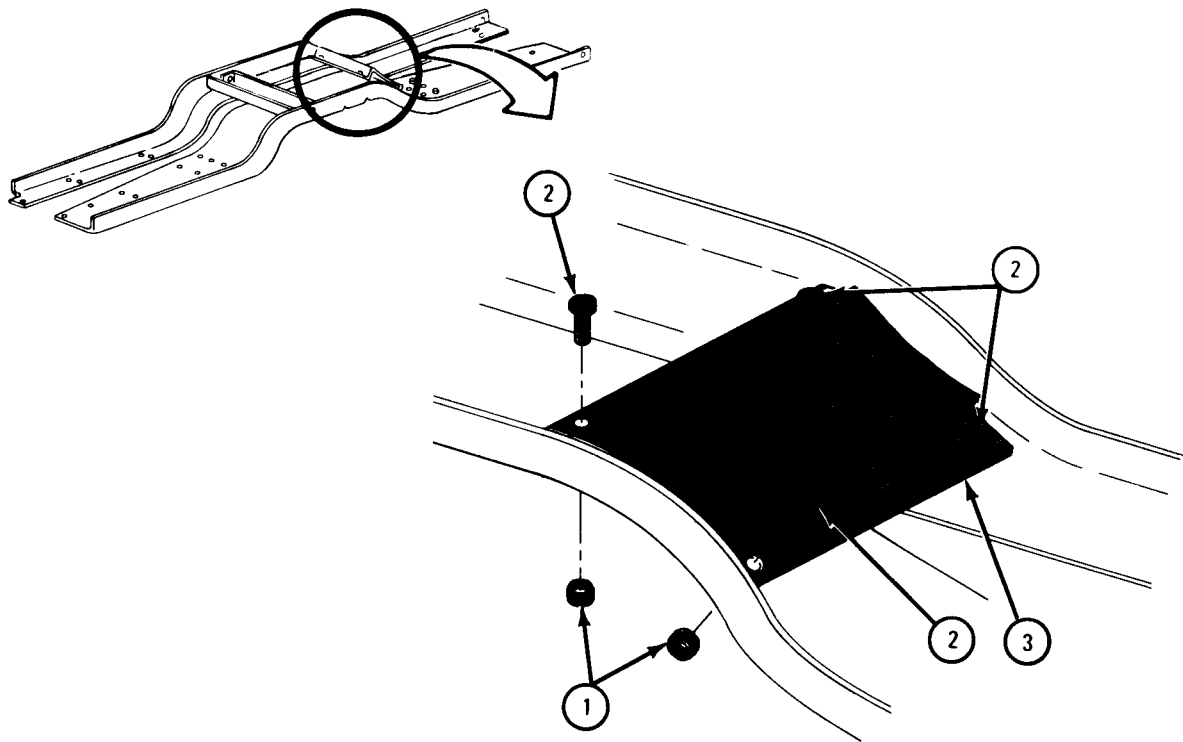

TA 046523

FRAME 7

1. Using 9/16-inch wrenches, unscrew and take out five nuts (1) and screws (2).
2. Take off brace (3).

END OF TASK

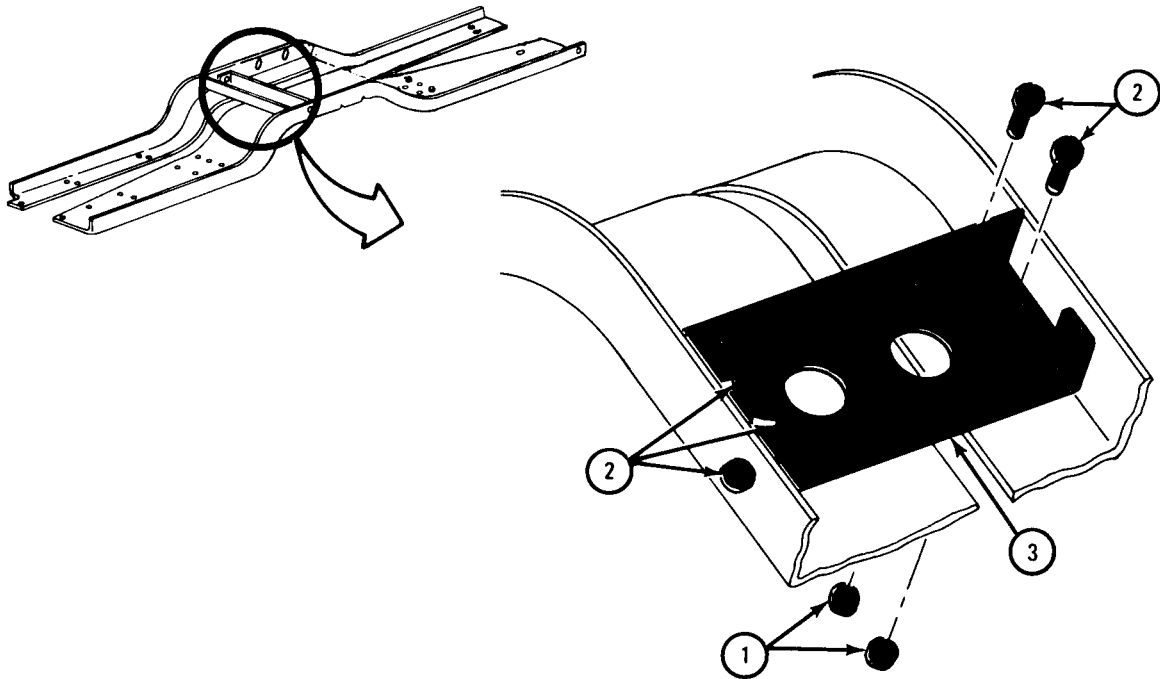

TA 046524

c. Repair. Repair of spare wheel carrier is limited to replacement of damaged parts.

d. Assembly.

FRAME 1

1. Put brace (1) on member (2) and cab support (3) and aline screw holes.
2. Put five screws (4) through screw holes in brace (1). Using 9/16-inch wrenches, screw on and tighten five nuts (5).

GO TO FRAME 2

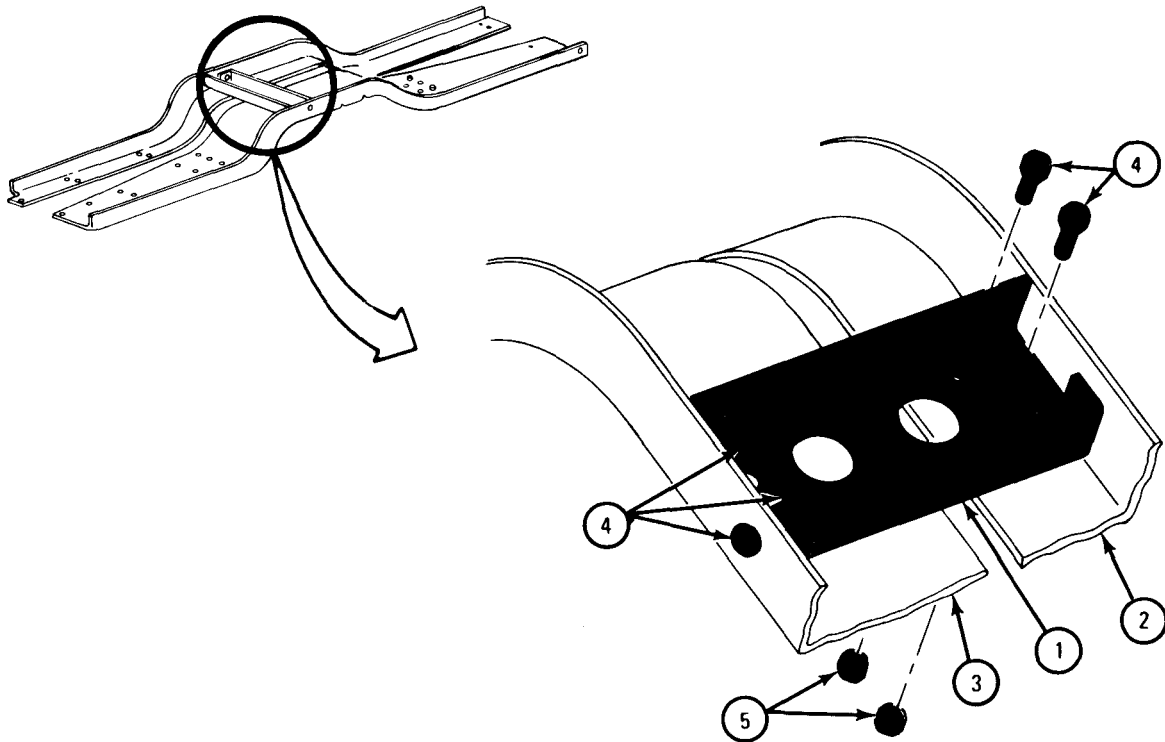

TA 046525

FRAME 2

1. Put support (1) on cab support (2) and member (3) and align screw holes.
2. Put four screws (4) through screw holes in support (1). Using 9/16-inch wrenches, screw on and tighten four nuts (5).

GO TO FRAME 3

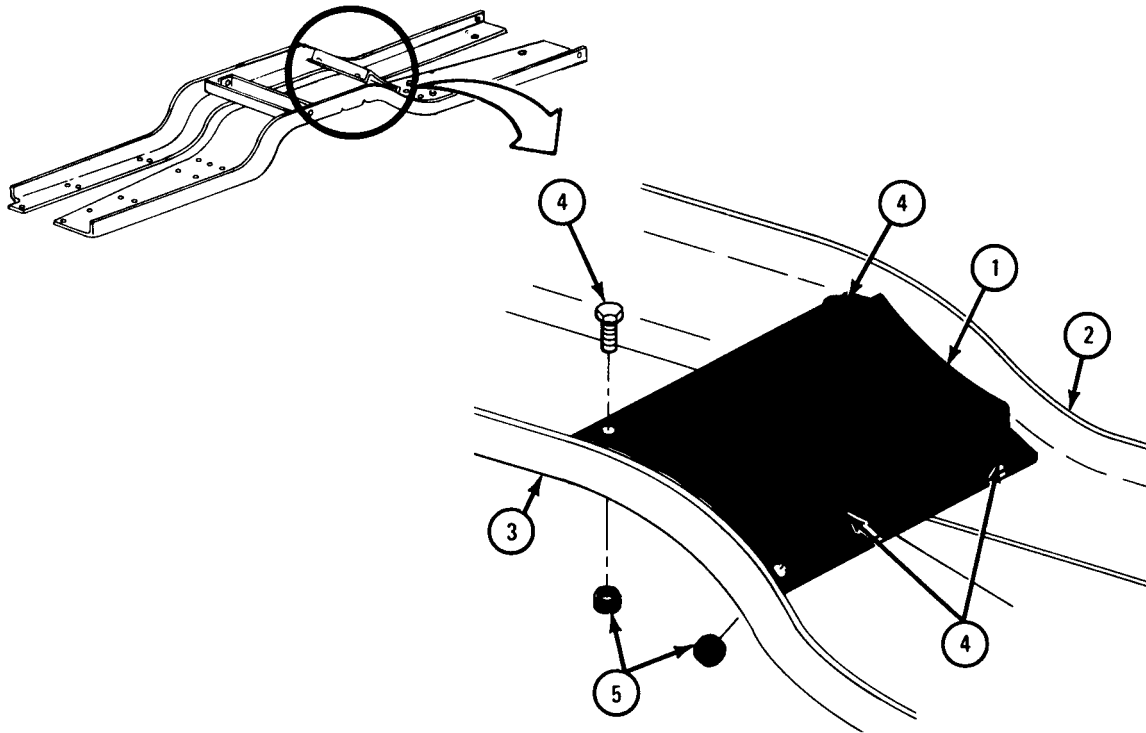

TA 046526

FRAME 3

1. Put support (1) on cab support (2) and member (3) and align screw holes.
2. Put four screws (4) through screw holes in support (1). Using 9/16-inch wrenches, screw on and tighten four nuts (5).
3. Put bracket (6) in place and align holes. Put two screws (7) through holes in bracket and support (1). Using 9/16-inch wrenches, screw on and tighten two nuts (8).

GO TO FRAME 4

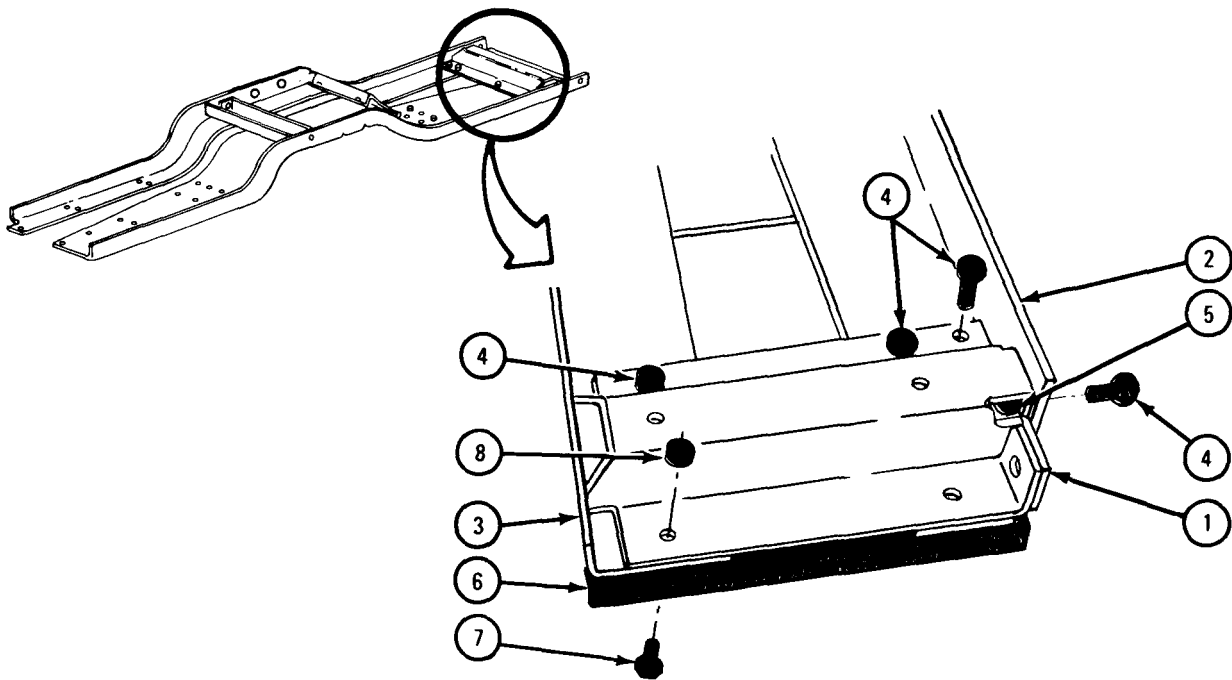

TA 046527

FRAME 4

1. Using prybar, raise back of cab and place wood block between cab and frame.
2. Put two rubber mounts (1) between brackets (2 and 3).
3. Put two washers (4), two springs (5), and two washers (6) onto two screws (7) and put screws through holes in bracket (2).
4. Using 15/16-inch wrenches, screw on and tighten two nuts (8) with two washers (9).

GO TO FRAME 5

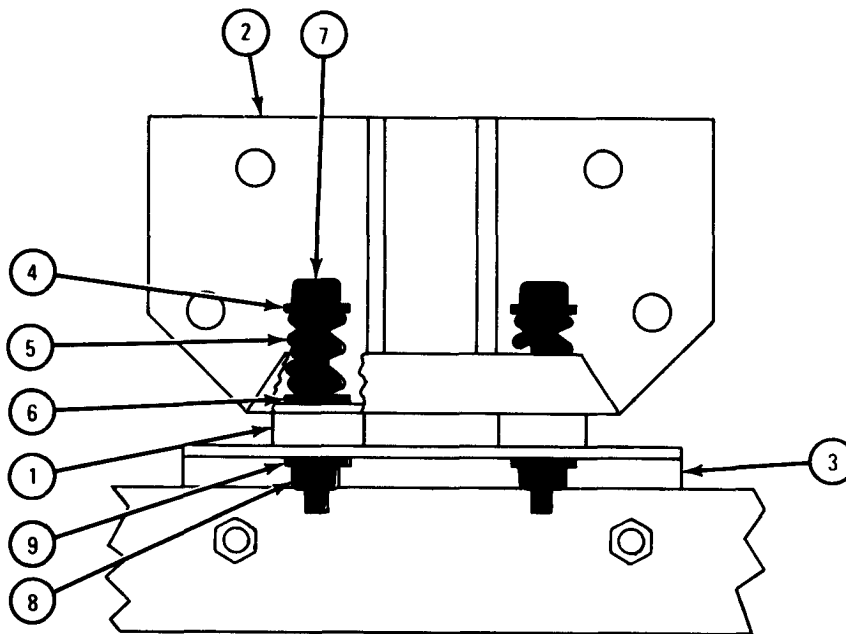

TA 046529

FRAME 5

1. Put screw (1) through cab support (2) and bar assembly (3). Using 15/16-inch wrenches, screw on and tighten nut (4).
2. Put screw (5) through bar assembly (3) and member (6). Using 15/16-inch wrenches, screw on and tighten nut (7).
3. Do steps 1 and 2 again for bar assembly (8).

GO TO FRAME 6

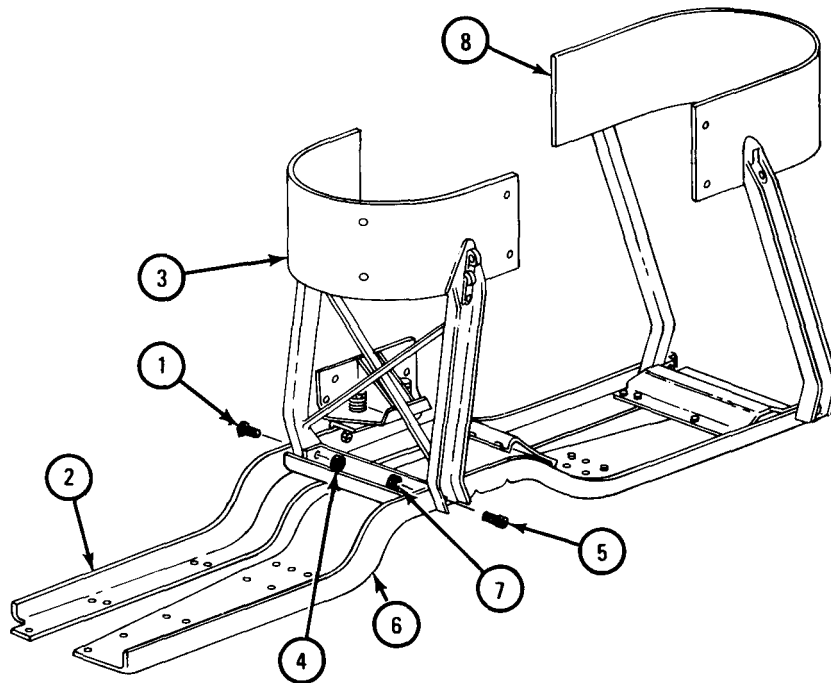

TA 046530

FRAME 6

1. Put spacer (1) on bar assembly (2) and align screw holes.
2. Put four screws (3) through holes in bar assembly (2) and spacer (1). Using 9/16-inch wrenches, screw on and tighten four nuts (4).
3. Do steps 1 and 2 again for spacer (5).

GO TO FRAME 7

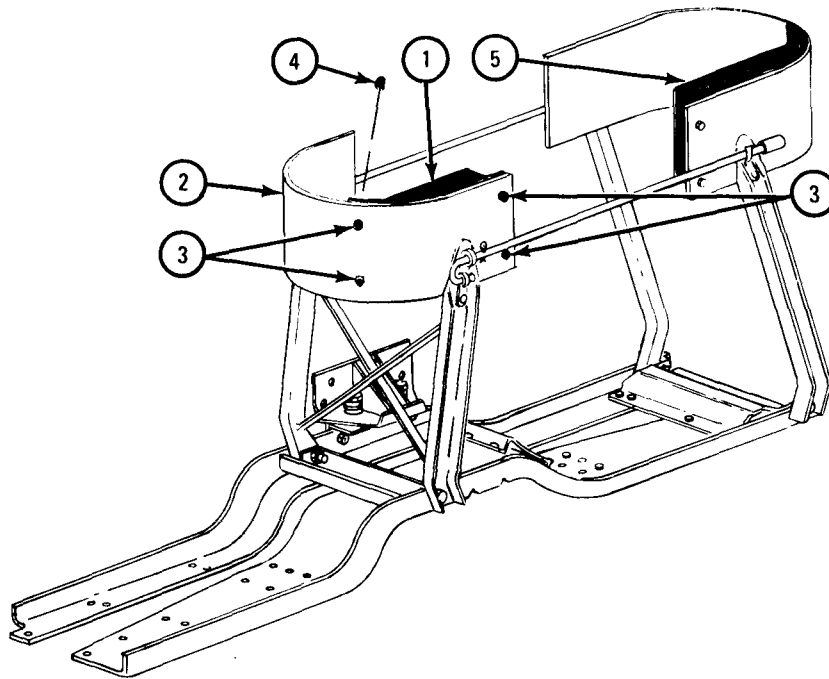

TA 046532

FRAME 7

1. Put hook bolt (1) through bar assembly (2). Make sure that hood bolt is in both holes of bar assembly.
2. Put cotter pin (3) through hole in hook bolt (1). Using pliers, spread open ends of cotter pin.
3. Put other end of hook bolt (1) through hole in bar assembly (4). Screw on sleeve nut (5).
4. Do steps 1, 2, and 3 again for hook bolt (6).

NOTE

Follow-on Maintenance Action Required:

Replace spare wheel carrier. Refer to para 16-9.

END OF TASK

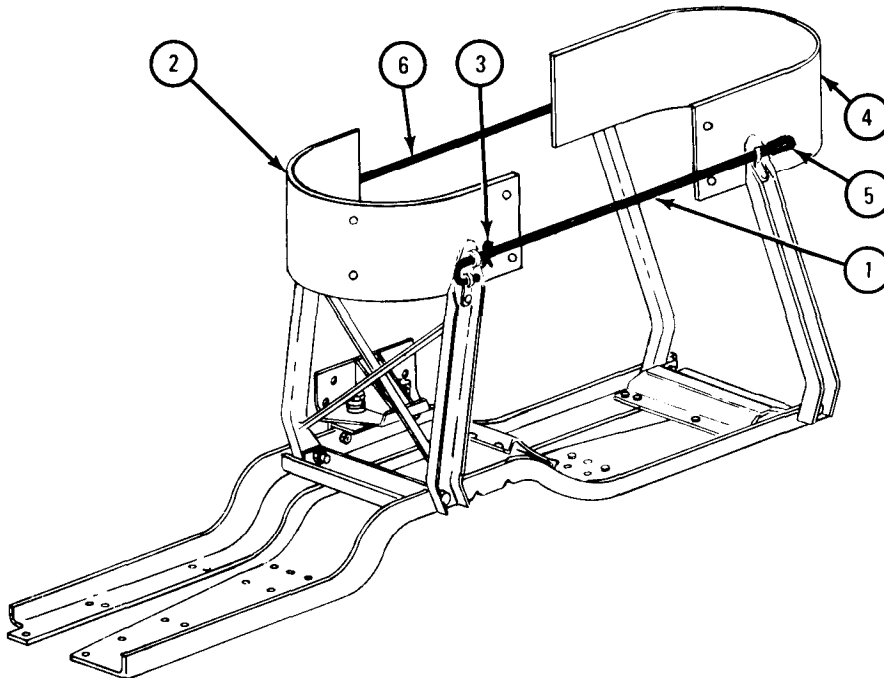

TA 046531

Section IV. FIFTH WHEEL ASSEMBLY

16-11. FIFTH WHEEL ASSEMBLY REMOVAL AND REPLACEMENT.

TOOLS: Hoist
15/16-inch wrench (2)

SUPPLIES: None

PERSONNEL: One

EQUIPMENT CONDITION: Truck parked, engine off, handbrake set.

a. Removal.

FRAME 1

1. Using 15/16-inch wrenches, unscrew and take off five nuts (1), screws (2), and washers (3 and 4).
 2. Go to other side of truck and do step 1 again for other side of fifth wheel.
- GO TO FRAME 2

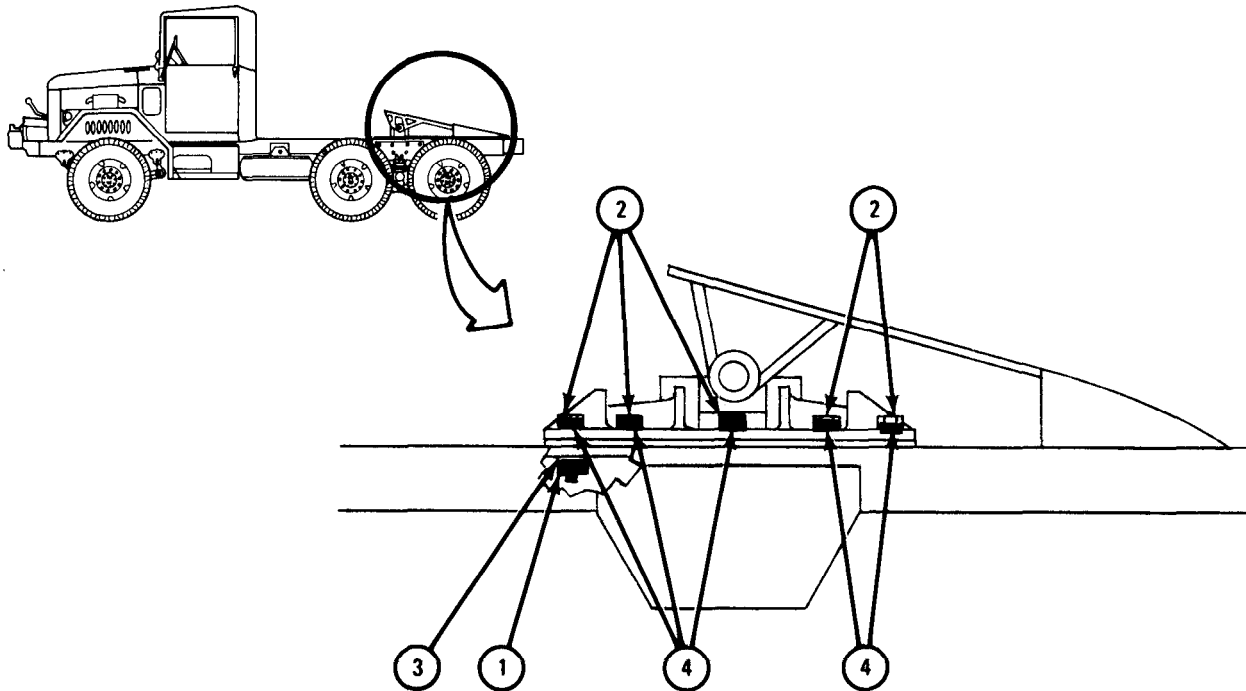

TA 046253

FRAME 2

1. Using hoist, take off fifth wheel assembly (1). Take off spacers (2) from both sides of truck frame.

END OF TASK

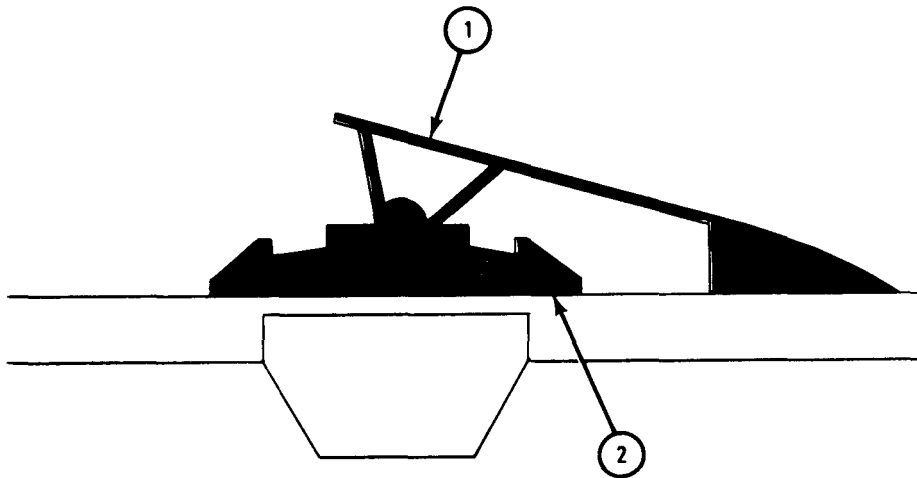

TA 046254

b. Replacement.

FRAME 1

1. Put spacer (1) on truck frame. Line up mounting screw holes in five places. Check that truck frame rivets are in their clearance holes and spacer is down on frame.
2. Do step 1 again for other spacer on other side of truck.
3. Using hoist, put fifth wheel (2) down on spacers (1), making sure that mounting holes line up.

GO TO FRAME 2

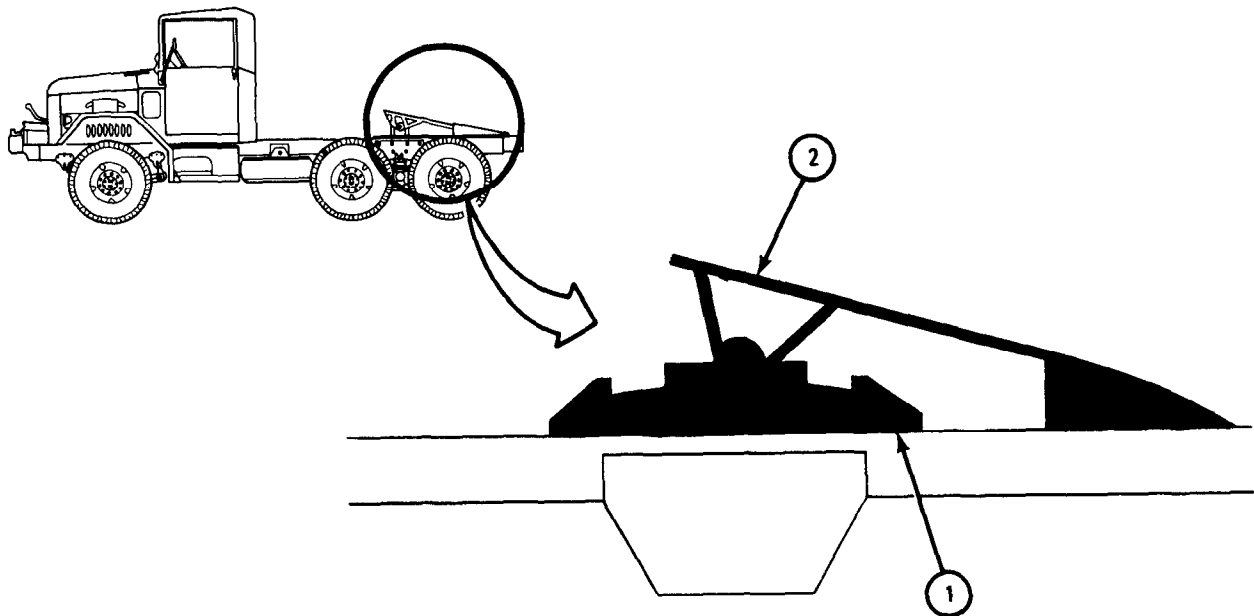

TA 046255

FRAME 2

1. Put flat washers (1) onto five screws (2). Put screw through mounting holes in fifth wheel (3), spacer (4), and truck frame (5).
2. Put flat washers (6) onto five screws (2) and using 15/16-inch wrenches, screw on and tighten five nuts (7).
3. Go to other side of truck and do steps 1 and 2 again for other side of fifth wheel (3).

END OF TASK

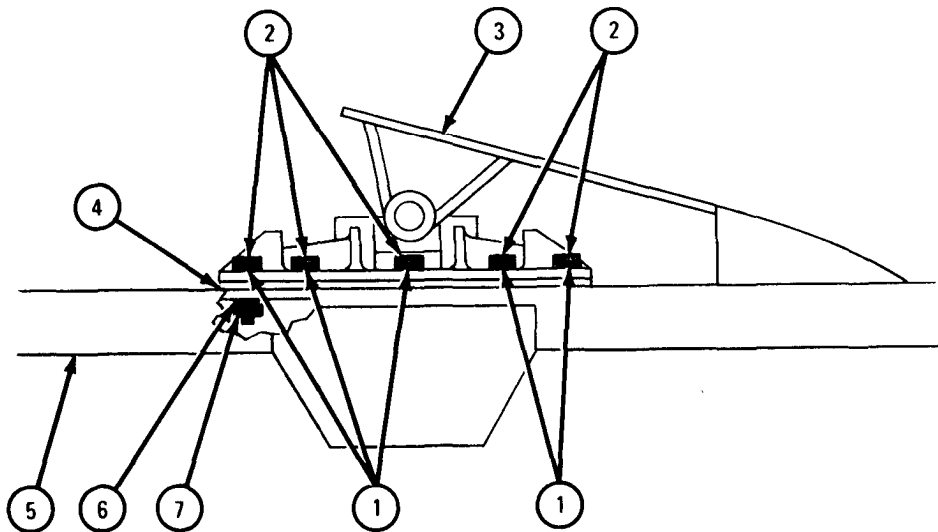

TA 046256

CHAPTER 17

SPRINGS AND SHOCK ABSORBERS GROUP MAINTENANCE

Section I. SCOPE

17-1. EQUIPMENT ITEMS COVERED. This chapter gives equipment maintenance procedures for the springs, shock absorbers, and torque rods for which there are authorized corrective maintenance tasks at the organizational maintenance level.

17-2. EQUIPMENT ITEMS NOT COVERED. All equipment items for which corrective maintenance is authorized at the organizational maintenance level are covered in this chapter.

Section II. SPRINGS

17-3. FRONT SPRINGS REMOVAL AND REPLACEMENT.

NOTE

This task is shown for the left front spring. This task is the same for the right front spring.

TOOLS: 1/2-inch to 3/4-inch drive adapter
 5/8-inch wrench (2)
 9/16-inch wrench (2)
 Torque wrench, 600 pound-feet capacity
 Strap wrench
 Screwdriver bit, 47/64 x 1/2-inch square drive
 Trestle, 5-ton capacity (2)
 Wood block, 12 x 12 inches (4)
 Brass drift punch
 Ballpeen hammer
 Hydraulic jack, 8-ton capacity
 1 1/16-inch deep socket

SUPPLIES: None

PERSONNEL: Two

EQUIPMENT CONDITION: Truck parked, engine off, handbrake set, rear wheels chocked.

a. Removal.

FRAME 1

1. Put hydraulic jack (1) under axle housing (2) as shown.

WARNING

Keep hands away from wheels when jacking up truck.
Wheels may turn as they clear the ground. Personnel
can be injured.

2. Using hydraulic jack (1), jack up truck until front wheels (3) are off ground about 6 inches.
3. Put trestle (4) on top of two wood blocks (5) and set trestle under frame as shown.
4. Do step 3 again on other side of truck.
5. Using hydraulic jack (1), jack truck down onto two trestles (4).
6. Using hydraulic jack (1), support weight of axle housing (2).

GO TO FRAME 2

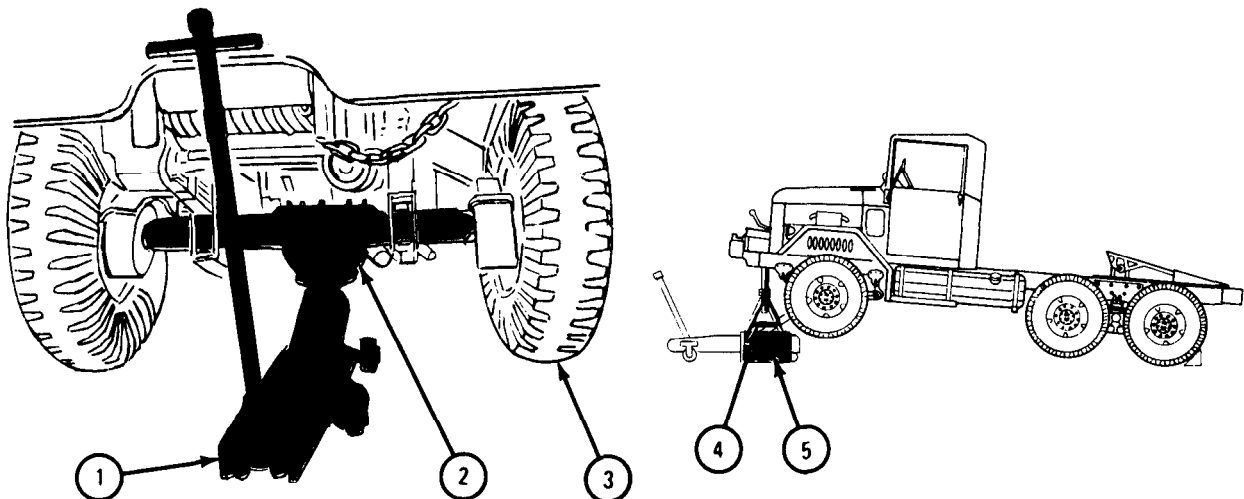

TA 086014

FRAME 2

1. Using 5/8-inch wrenches, hold nut (1) and unscrew and take off nut (2).
2. Using strap wrench, hold shock absorber (3).
3. Using 5/8-inch wrench, unscrew and take off nut (1).
4. Take off retainer (4) and bushing (5).
5. Push screw end of shock absorber (3) out of hole in plate (6). Take off rubber bushing (7) and retainer (8).

GO TO FRAME 3

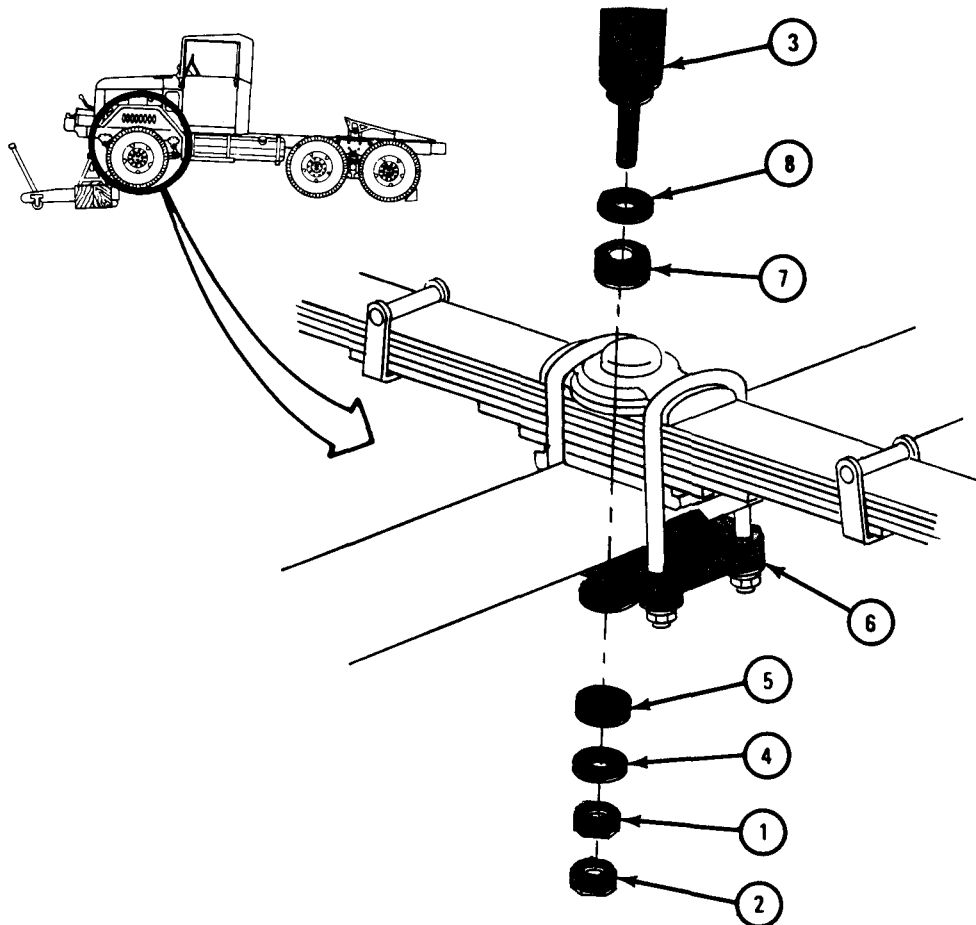

TA 046243

FRAME 3

1. Using 1 1/16-inch deep socket wrench, unscrew and take off four nuts with lockwashers (1). Take out plate (2).
 2. Take off two U-bolts (3). Take off saddle (4) and rubber bumper (5).
- GO TO FRAME 4

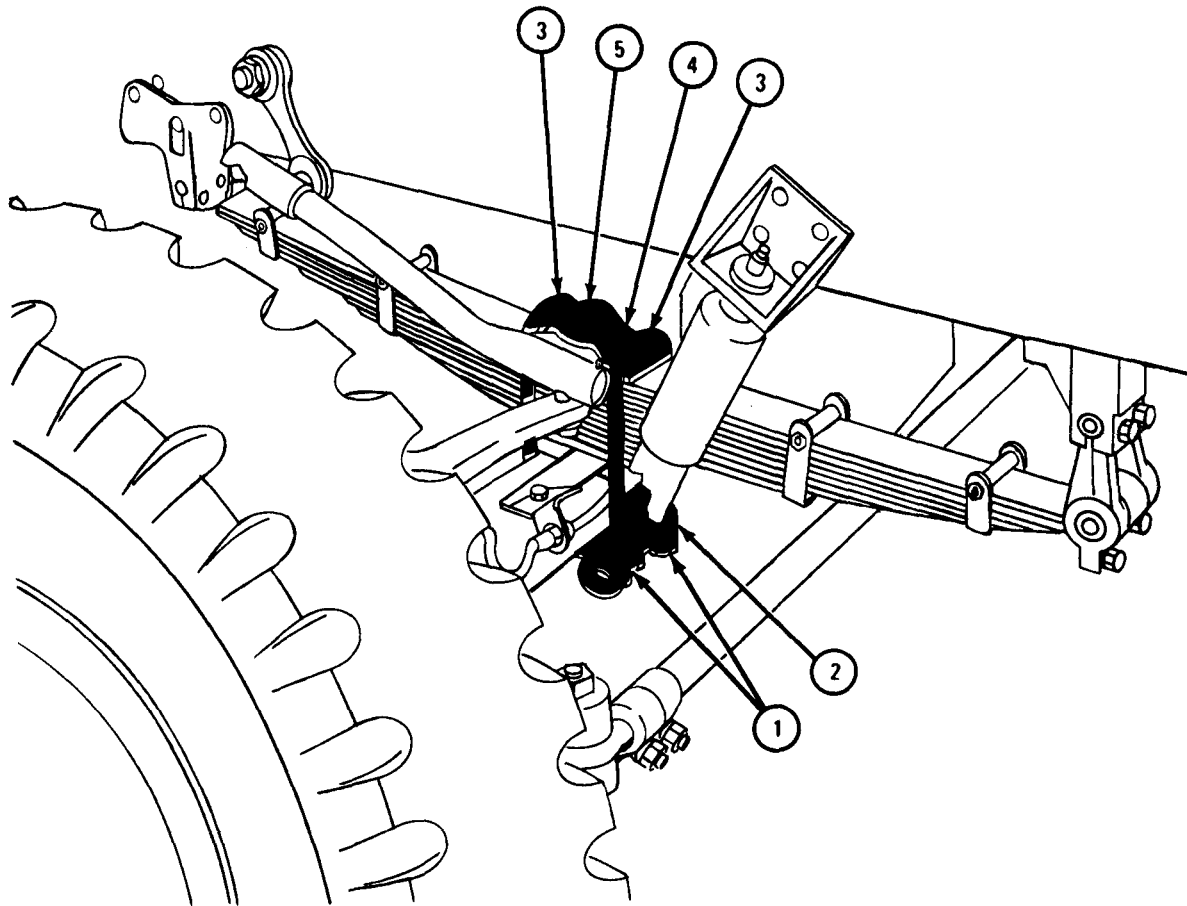

TA 046244

FRAME 4

WARNING

While working on spring, keep body clear of underside of spring. When parts are taken off, spring may come out and cause injury.

- Soldier A 1. Using 9/16-inch wrenches, unscrew and take off four screws (1) and four nuts (2).
2. Hold spring (3) in place.
- Soldier B 3. Working under truck and using drift punch and hammer, drive out two pins (4).
4. Push shackle (5) out of hanger (6) towards front of truck. Tap shackle with mallet if needed.
5. Using hydraulic jack, lower axle (7) to clear spring seat (8).
- Soldiers 6. Take out spring (3).
A and B
- END OF TASK

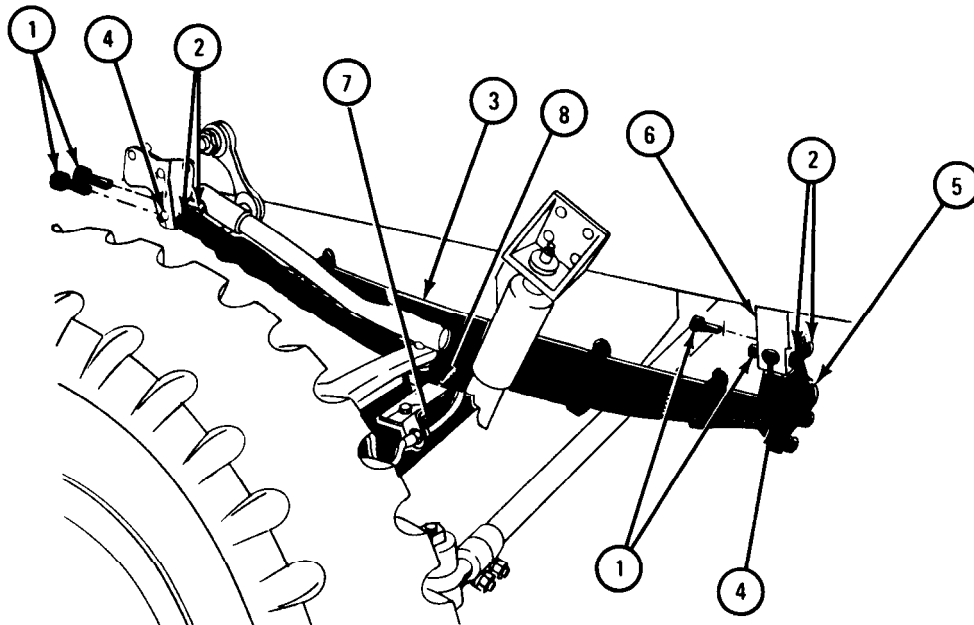

TA 046242

b. Replacement.

NOTE

If new spring is being put in, change both front springs.

FRAME 1

Soldier A 1. Check that spring seat (1) is sitting on axle housing (2).

Soldiers 2. Put spring (3) on spring seat (1).
A and B

Soldier A 3. Hold spring (3) in place.

GO TO FRAME 2

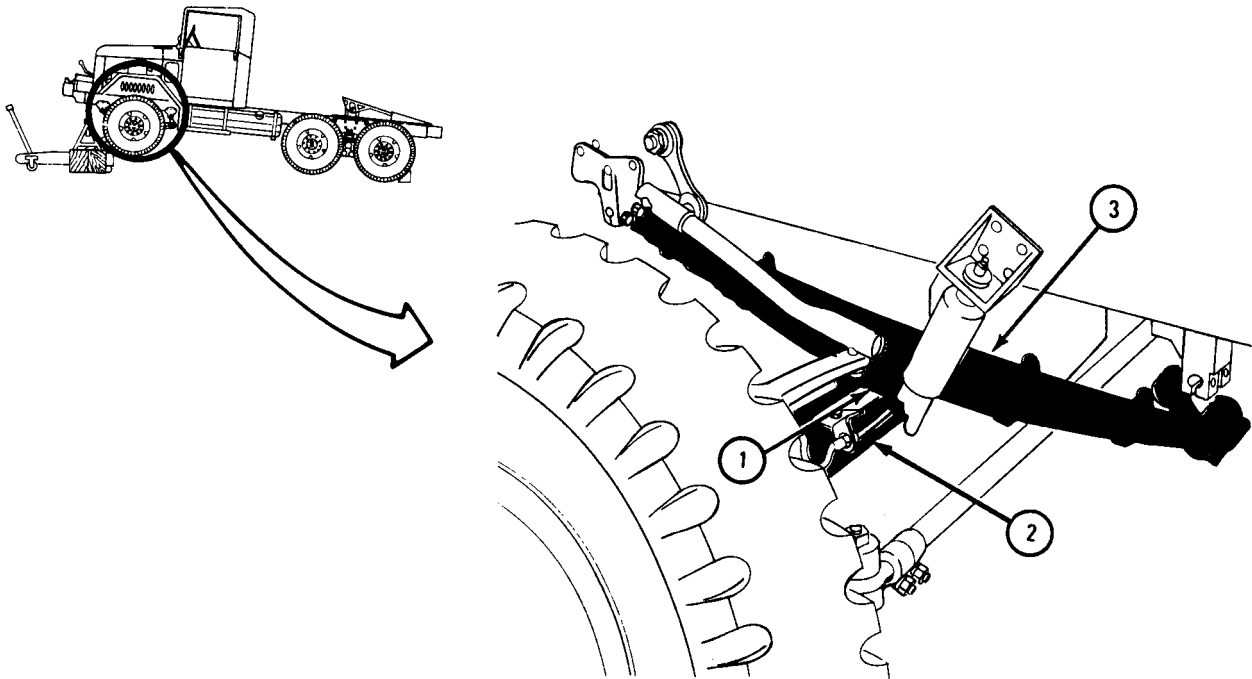

TA 084086

FRAME 2

Soldier B 1. Put eye of spring (1) in hanger (2) and aline holes.

NOTE

If needed, use hydraulic jack to move axle housing up or down to aline holes.

Soldier A 2. Put in pin (3).

3. Using socket wrench handle and screwdriver bit, turn pin (3) until slots in pin aline with holes in hanger (2). Put in two screws (4).

4. Using 9/16-inch wrenches, screw on and tighten two nuts (5).

GO TO FRAME 3

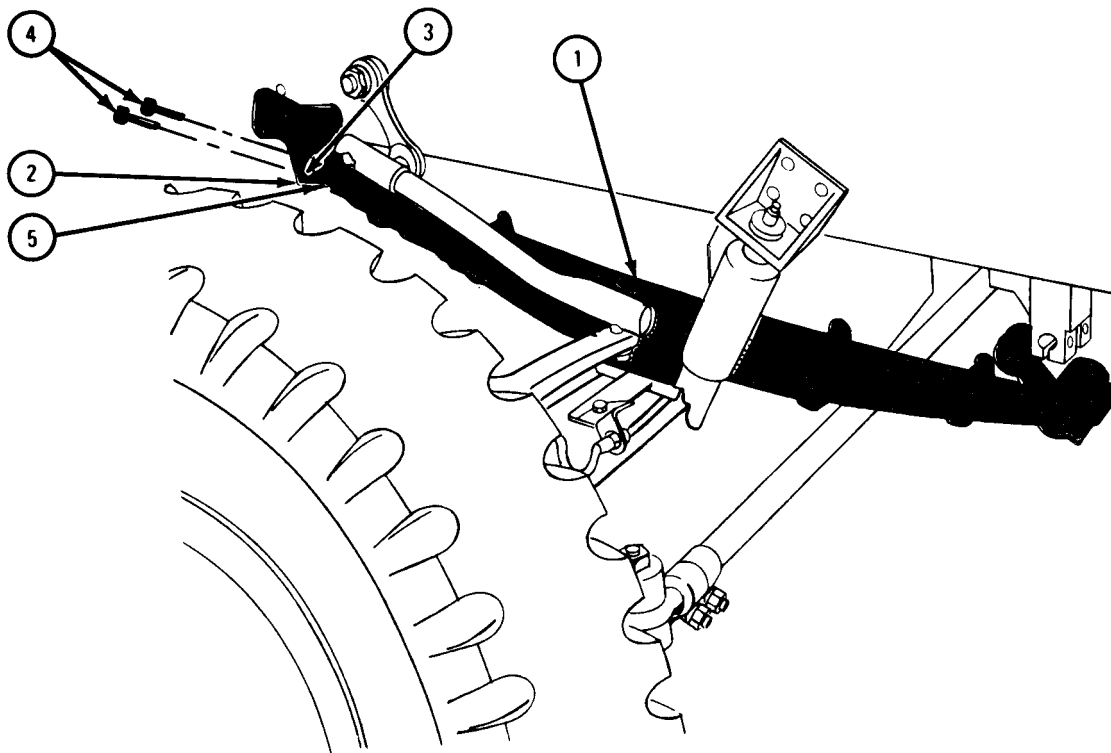

TA 046245

FRAME 3

Soldier A 1. Put shackle (1) in hanger (2) and aline holes.

Soldier B 2. Put in pin (3).

3. Using socket wrench handle and screwdriver bit, turn pin (3) until slots in pin aline with holes in hanger (2). Put in two screws (4).

4. Using 9/16-inch wrenches, screw on and tighten two nuts (5).

GO TO FRAME 4

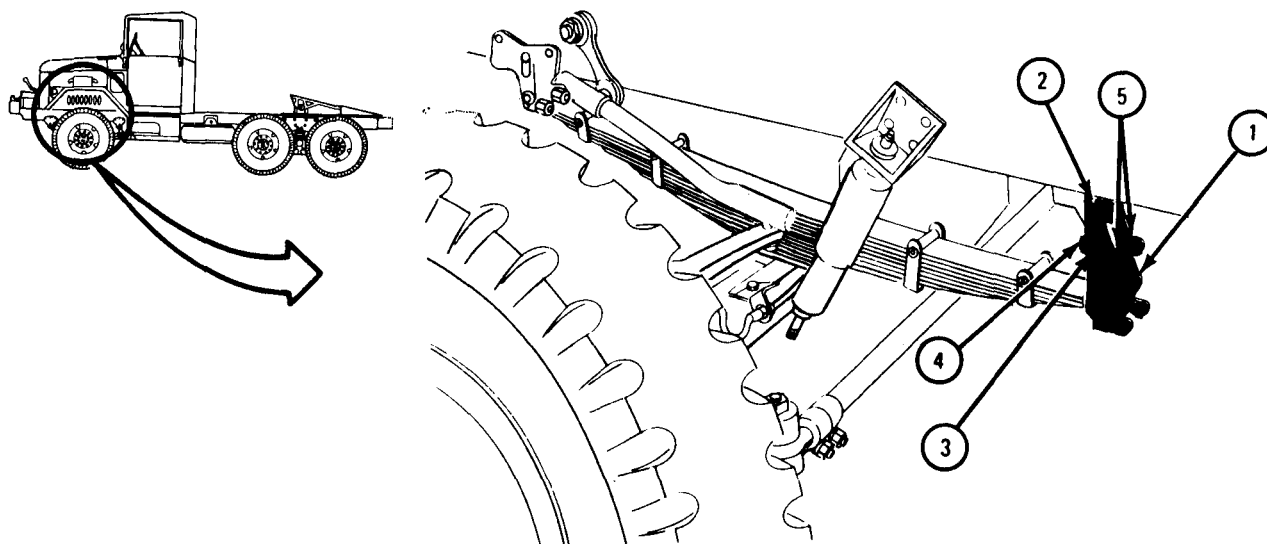

TA 046247

FRAME 4

Soldiers 1. Move axle housing (1) back and forth to be sure that center A and B screw of spring (2) is in hole in spring seat (3).

Soldier A 2. Put rubber bumper (4) in spring saddle (5).

3. Put saddle (5) on spring (2) as shown.

GO TO FRAME 5

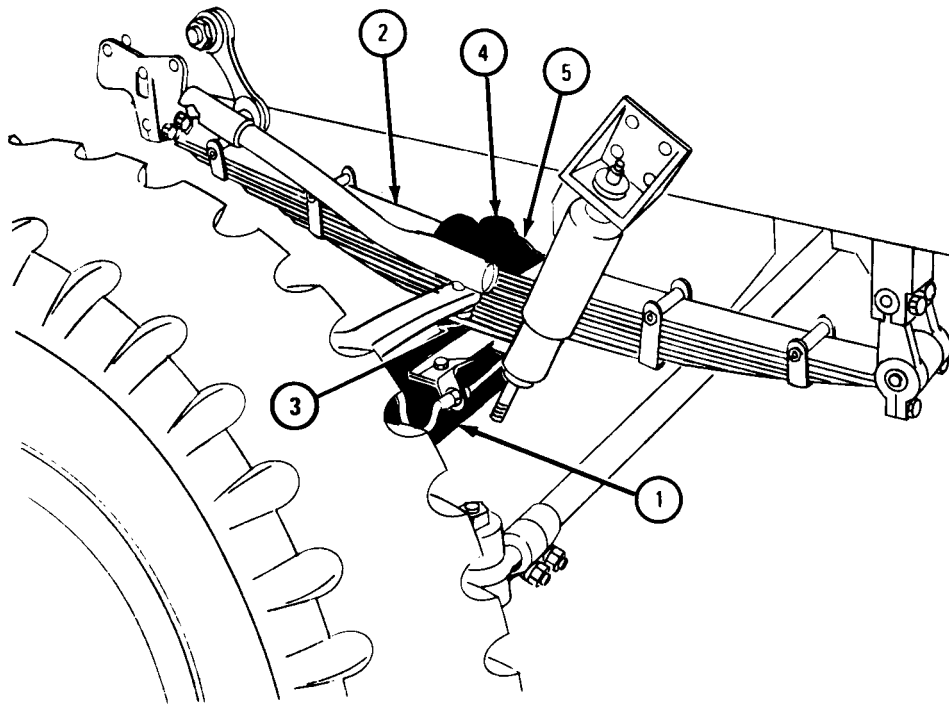

TA 086016

FRAME 5

1. Put plate (1) under axle housing (2) with hole for shock absorber to back of truck.
2. Put two U-bolts (3) over saddle (4) and through holes in plate (1).
3. Using 1 1/16-inch wrench, screw on four nuts with lockwashers (5).
4. Using 1 1/16-inch socket and 3/4-inch square drive torque wrench, tighten nuts (5) to 170 to 180 pound-feet.

GO TO FRAME 6

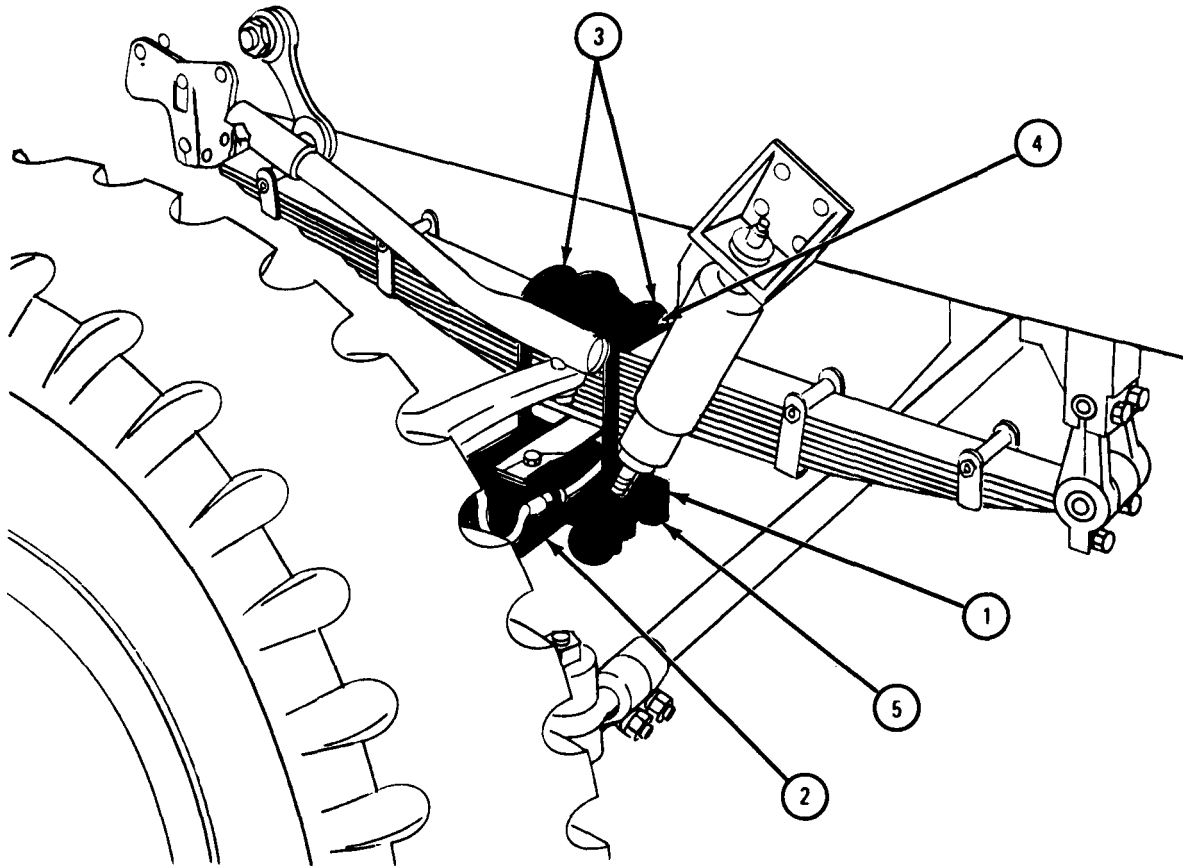

TA 086017

FRAME 6

1. Put retainer (1) and rubber bushing (2) on screw end of shock absorber (3). Pull screw end of shock absorber (3) down and through hole in plate (4).
2. Put on rubber bushing (5) and retainer (6).
3. Using strap wrench, hold shock absorber (3). Using 5/8-inch wrench, screw on and tighten nut (7). Using 5/8-inch wrenches, hold nut (7) and screw on and tighten nut (8).

GO TO FRAME 7

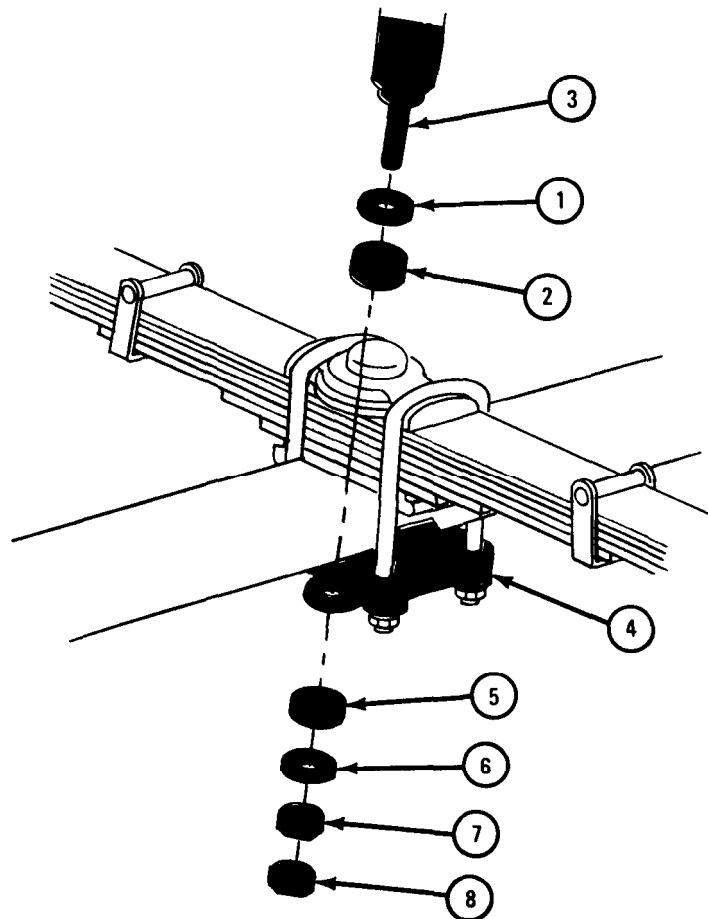

FRAME 7

1. Using hydraulic jack (1), jack up truck until truck is off two trestles (2).
2. Take out two trestles (2) and four wood blocks (3).
3. Using hydraulic jack (1), lower truck onto ground. Take away hydraulic jack (1).

GO TO FRAME 8

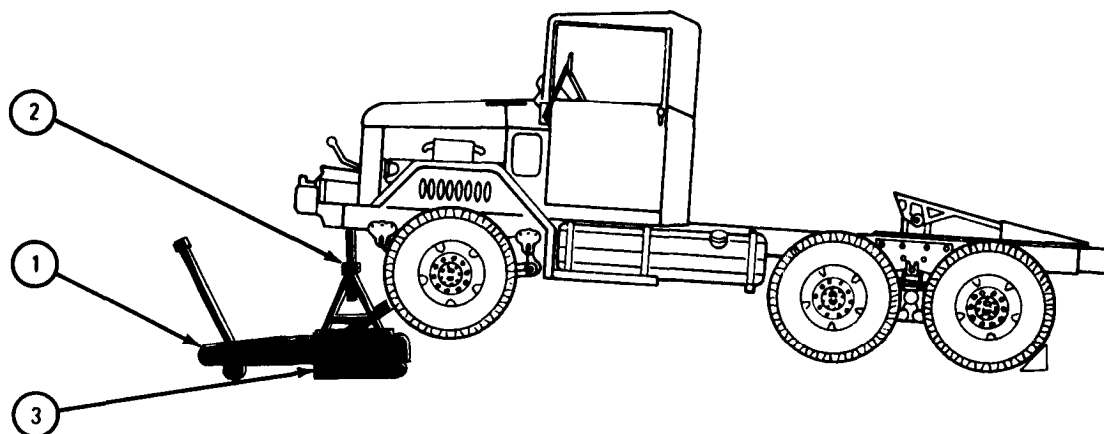

TA 086015

FRAME 8

1. Check that rebound clips (1) are not loose on spring. If they are loose, using 9/16-inch wrenches, hold four screws (2) and tighten four nuts (3).
2. Using ballpeen hammer, peen over ends of four screws (2).

END OF TASK

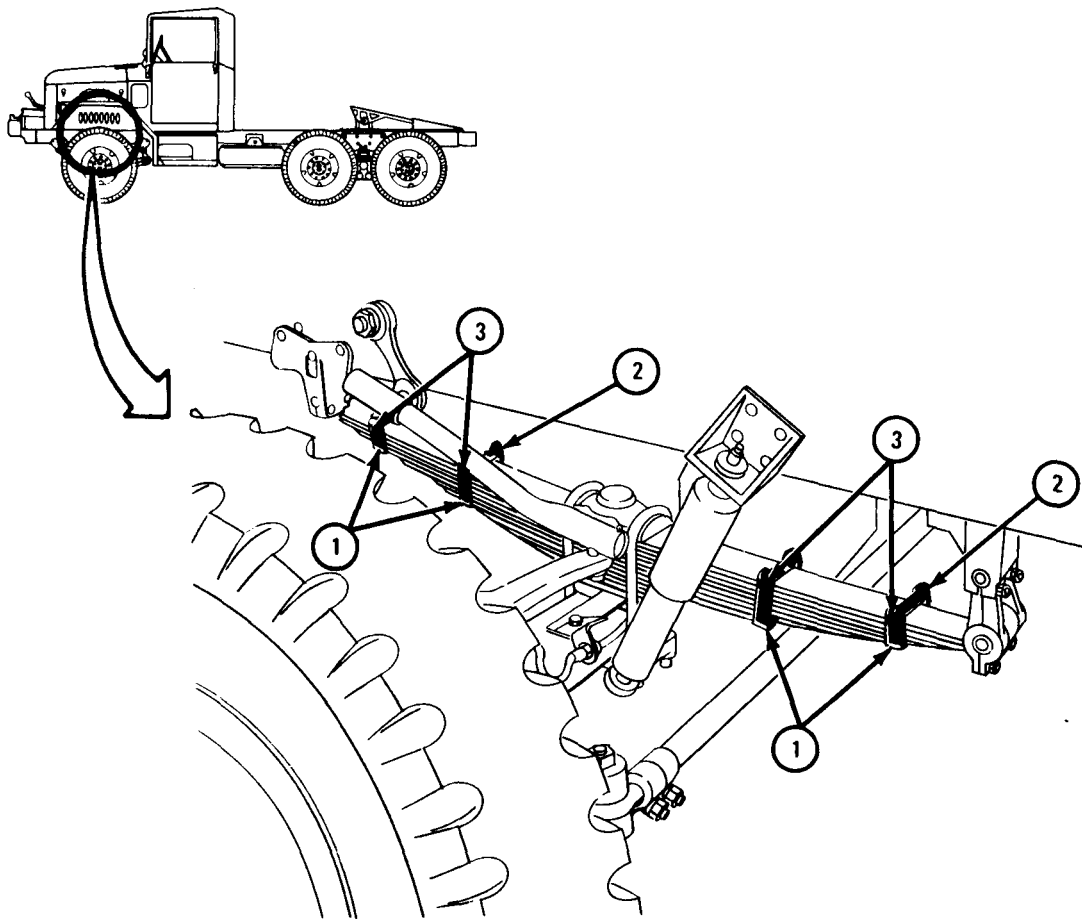

TA 046248

17-4. FRONT LEAF SPRING ASSEMBLY REPAIR.

TOOLS: File 1/4-inch center punch
9/16-inch wrench Drift punch
11/16-inch wrench Vise grip pliers
Wire brush Drill press
Medium ballpeen hammer 3/8-inch drill bit
Heavy duty C-clamp 3/8-inch driving pin punch
Arbor press

SUPPLIES: Solvent, dry cleaning, type II (SD-2), Fed. Spec P-D-680
Anti-seize compound, white lead, general purpose,
TT-A-680-B-2
Leaf clip bolt (4)
Leaf clip bolt nut (4)
Leaf clip rivet (4)
Center bolt
Center bolt nut

PERSONNEL: One

EQUIPMENT CONDITION: Truck parked, engine off, handbrake set, rear wheels chocked.

a. Preliminary Procedure. Take front spring off truck. Refer to para 17-3.

b. Disassembly.**FRAME 1****NOTE**

Some front springs (type A) will have two leaf springs (1) and eight plates (2). Others (type B) will have two leaf springs (1) and ten plates (2). This task is shown for the type A spring. This task is the same for the type B spring except that it has two more plates.

1. Only the two leaf springs (1) may be replaced. Throw away any spring that has damaged plates (2).

GO TO FRAME 2

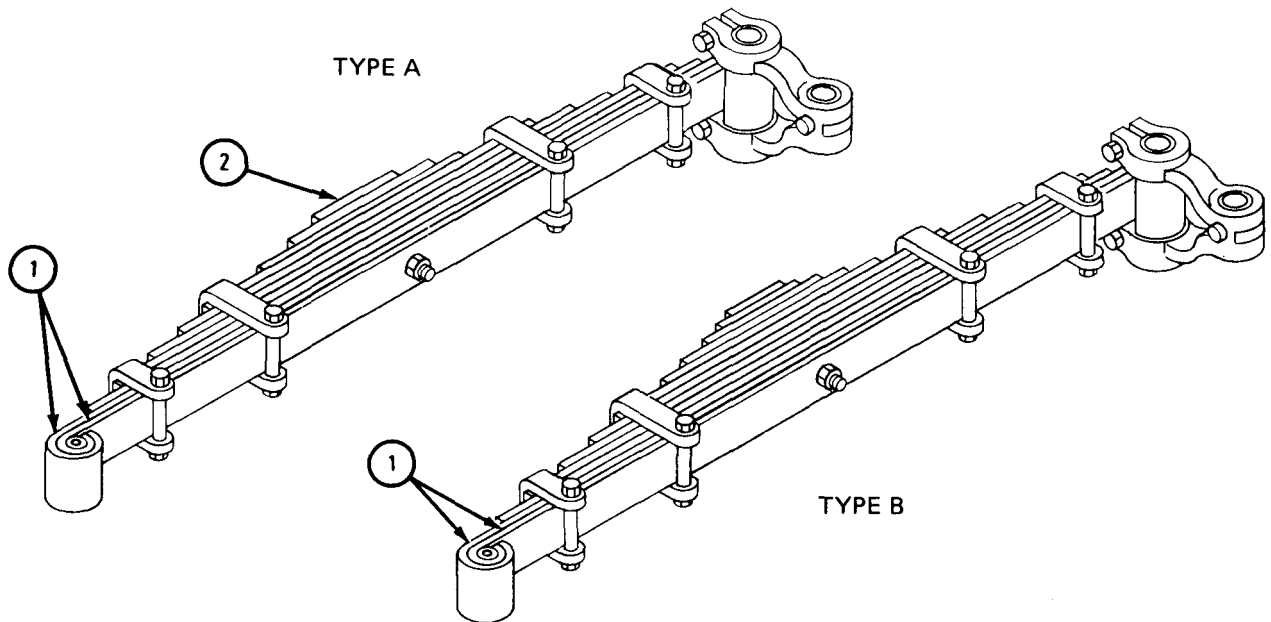

TA 046326

FRAME 2

1. Using 9/16-inch wrenches, unscrew and take off two screws (1) and two nuts (2).
2. From other side of grease fitting, using drift punch and hammer, drive out pin (3).
3. Take shackle (4) off spring (5).

GO TO FRAME 3

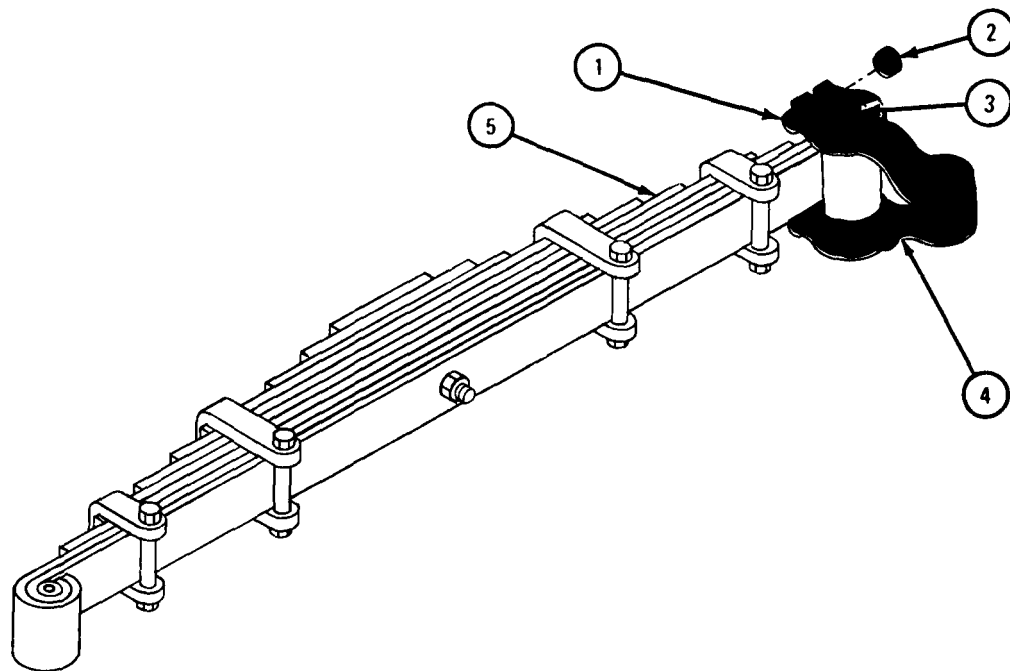

TA 046327

FRAME 3

WARNING

Springs are under tension. Use C-clamp to hold spring together when taking it apart. Be careful to avoid injury.

1. Using C-clamp, clamp spring (1) about 2 inches from either side of center bolt (2).
2. Using file, file off peened-over ends of four screws (3) down to four nuts (4).
3. Using 9/16-inch wrenches, hold four screws (3) and unscrew and take off four nuts (4). Throw away nuts.
4. Take out four screws (3) and four spacers (5). Throw away screws (3).
5. Using file, file off peened-over end of center bolt (2) down to nut (6).
6. Using vise grip pliers, hold head of center bolt (2). Using 9/16-inch wrench, unscrew and take off center bolt nut (6). Throw away nut.
7. Carefully unscrew C-clamp, releasing spring tension until clamp can be freely taken off from spring (1).

GO TO FRAME 4

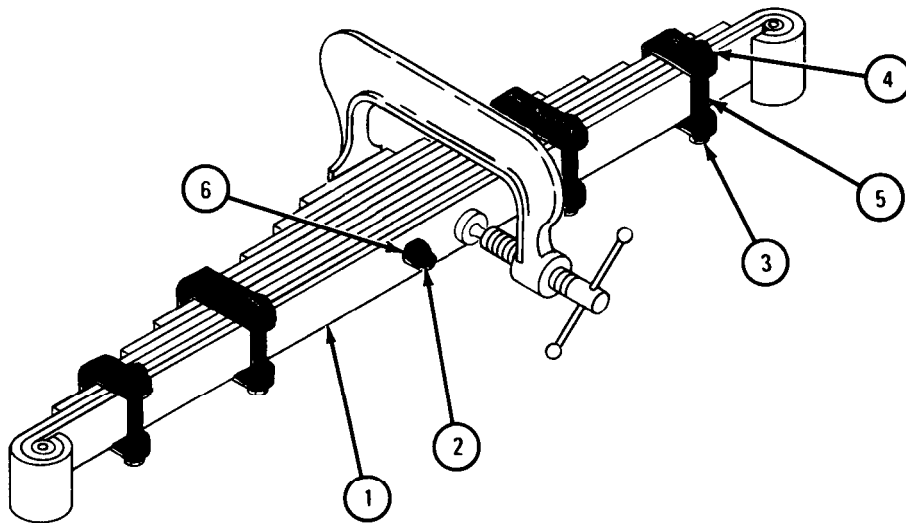

TA 046330

FRAME 4

1. Take out center bolt (1) and throw it away.
2. Take off eight plates (2), starting with the smallest.
3. Take leaf spring (3) out of leaf spring (4).

GO TO FRAME 5

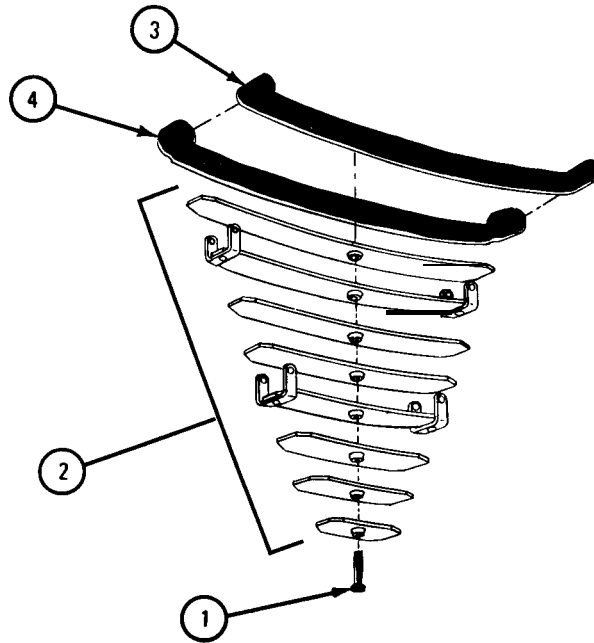

TA 084236

FRAME 5

1. Using 1/4-inch center punch and hammer, make a shallow hole in center of rivet (1).
2. Using drill press with 3/8-inch drill bit, drill out rivet (1).
3. Using 3/8-inch driving pin punch and hammer, drive out rivet (1). Throw away rivet and take off clip (2).
4. Do steps 1 through 3 again for three clips (3, 4, and 5).

END OF TASK

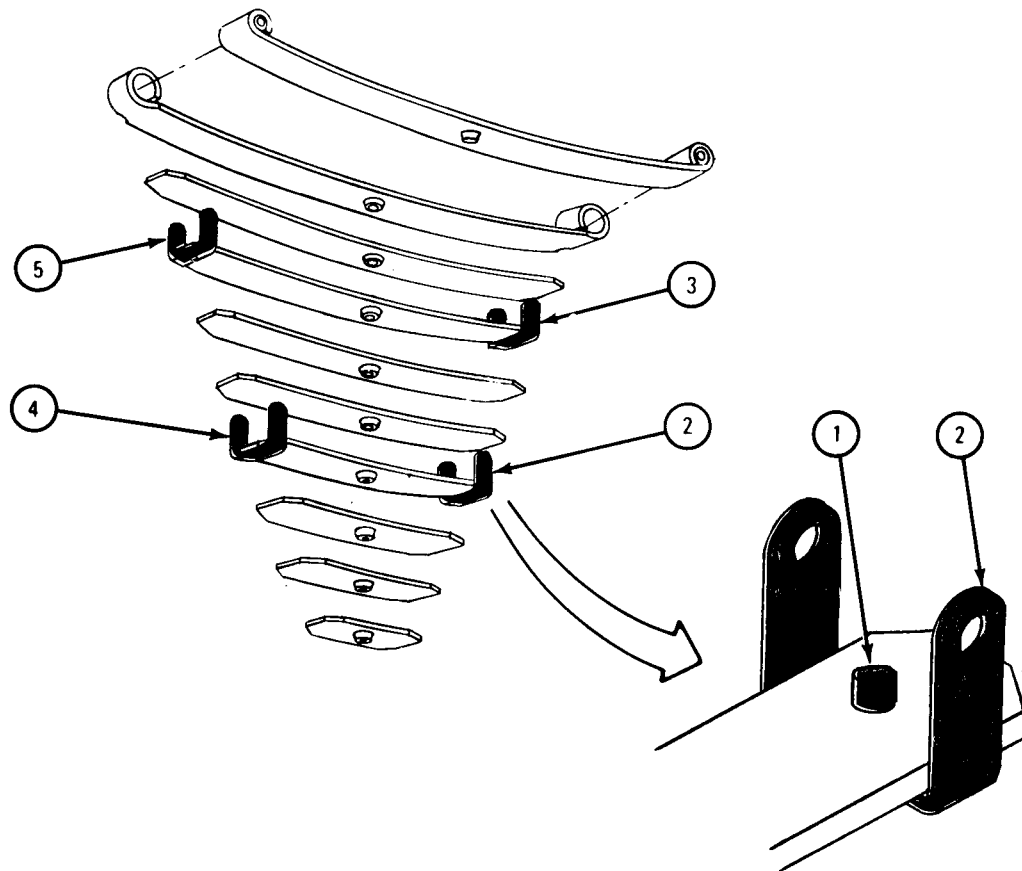

TA 084237

c. Cleaning, Inspection, and Repair.

FRAME 1

WARNING

Dry cleaning solvent is flammable. Do not use near an open flame. Keep a fire extinguisher nearby when solvent is used. Use only in well-ventilated places. Failure to do this may result in injury to personnel and damage to equipment.

1. Using wire brush, clean off any dirt, rust or corrosion.
2. Clean all parts in solvent.
3. Check that all parts are not cracked, worn, broken, or damaged in any other way.
4. If spring eye sleeve bearings (1) or shackle pin sleeve bearing (2) are worn or damaged, using arbor press, press them out. Get new ones in their place.
5. Throw away any worn or damaged parts and get new ones in their place.

END OF TASK

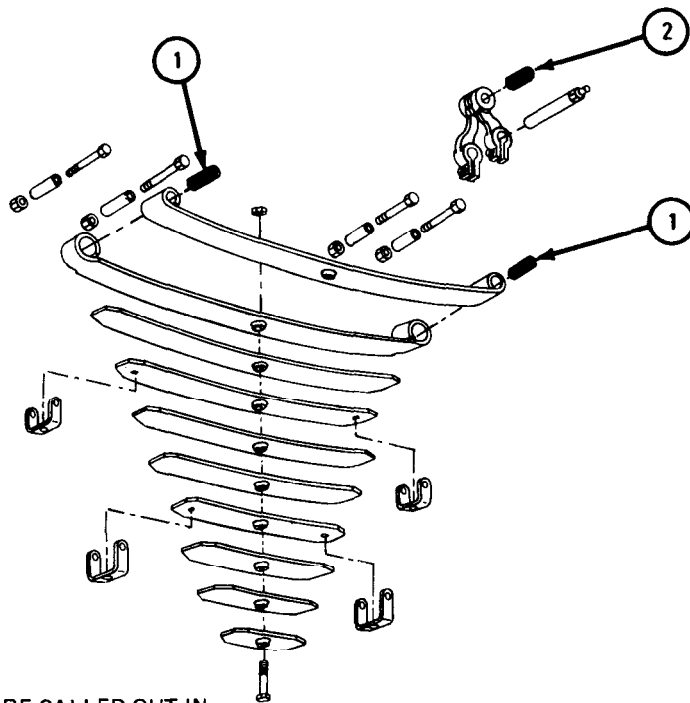

NOTE
CHECK ONLY THOSE PARTS WHICH ARE CALLED OUT IN THIS FRAME. PARTS WITHOUT CALLOUTS ARE SHOWN ONLY FOR REFERENCE PURPOSES OR ARE CHECKED IN ANOTHER FRAME.

TA 046328

d. Assembly.

FRAME 1

1. If spring eye sleeve bearings (1) or shackle pin sleeve bearing (2) were taken out, using arbor press, press in new ones.
2. Put long clip (3) on plate (4) and aline holes. Put rivet (5) through clip and plate.
3. Place plate (4), clip (3), and rivet (5) on hard surface with rivet head down.
4. Using hammer and center punch, spread and peen end of rivet (5) into tapered hole in plate (4).
5. Do steps 2, 3, and 4 again to put long clip (6) on other end of plate (4).
6. Do steps 2, 3, and 4 again to put short clips (7 and 8) on ends of plate (9).

GO TO FRAME 2

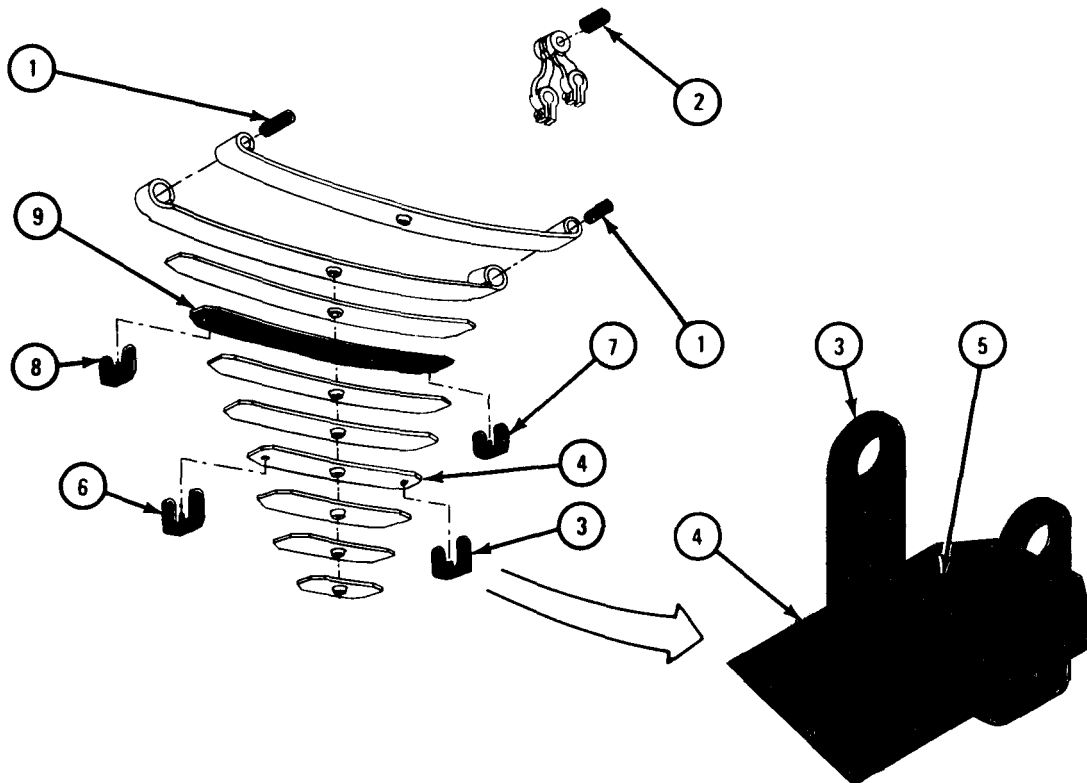

TA 046329

FRAME 2

WARNING

Clean hands carefully after using anti-seize compound. It contains lead and even small amounts will cause serious illness.

1. Put a light coat of anti-seize compound on top of leaf spring (1) and eight plates (2).
2. Slide spring leaf (3) into spring leaf (1).
3. Stack eight plates (2) in place on leaf spring (1), alining plates and holes.
4. Put center bolt (4) through holes as far as it will go.
5. Clamp C-clamp around leaf springs (1 and 3) and plates (2) two inches from center bolt holes (5).
6. Using C-clamp, tighten stack of leaf springs (1 and 3) and plates (2) until nut (6) can be put on center bolt (4).
7. Check alinement of all plates (2) and leaf springs (1 and 3).
8. Using vise grip pliers, hold center bolt (4). Using 9/16-inch wrench, tighten nut (6).
9. Unscrew C-clamp and take it off.

GO TO FRAME 3

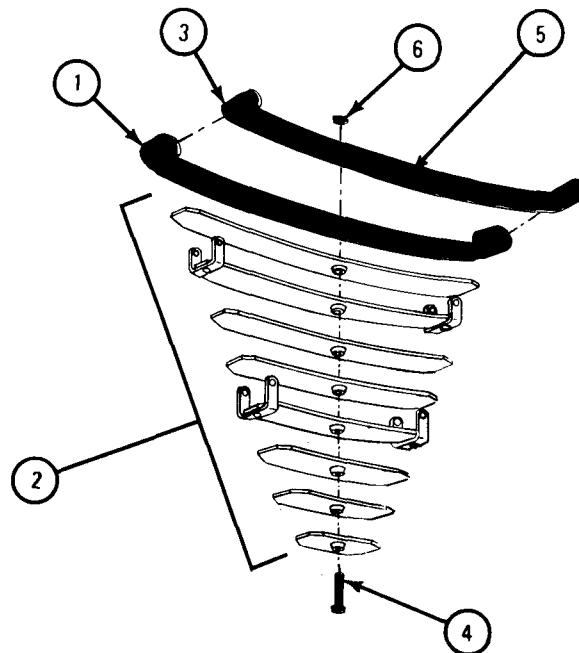

TA 084238

FRAME 3

1. Put spacer (1) in clip (2) and align screw holes. Put screw (3) through holes.
2. Using 9/16-inch wrenches, screw on and tighten nut (4) on screw (3). Do not overtighten nut. Clip (2) should not bind spring plates (5).
3. Do steps 1 and 2 again for clips (6, 7, and 8).

GO TO FRAME 4

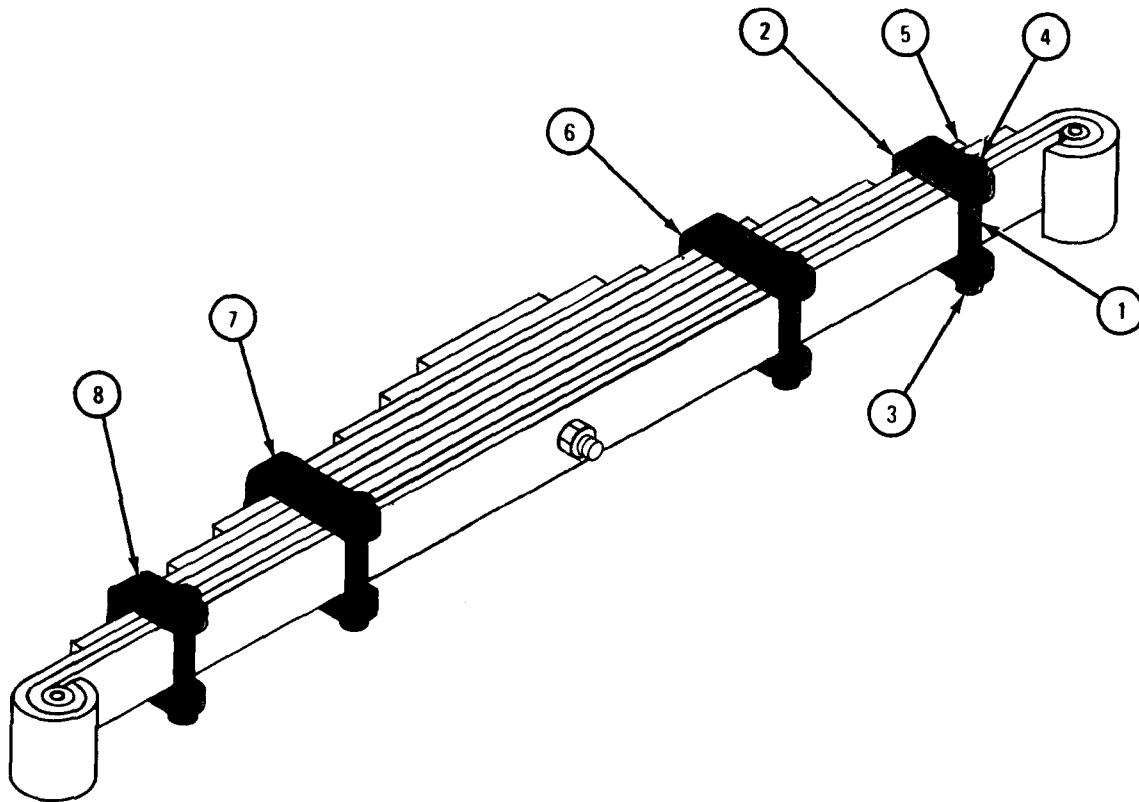

TA 046331

FRAME 4

1. Using ballpeen hammer, peen over ends of four screws (1) and screw (2) so nuts will not unscrew.

NOTE

Put in pin (3) so that grease fitting (4) will be toward outside of truck.

2. Put shackle (5) on spring (6), alining holes. Hold pin (3) so slots in pin line up with screw holes and using hammer, tap pin into place.
3. Put two screws (7) in place in shackle (5).
4. Using 9/16-inch wrenches, screw on and tighten two nuts (8).

NOTE

Follow-on Maintenance Action Required:

Put front spring back in truck. Refer to para 17-3.

END OF TASK

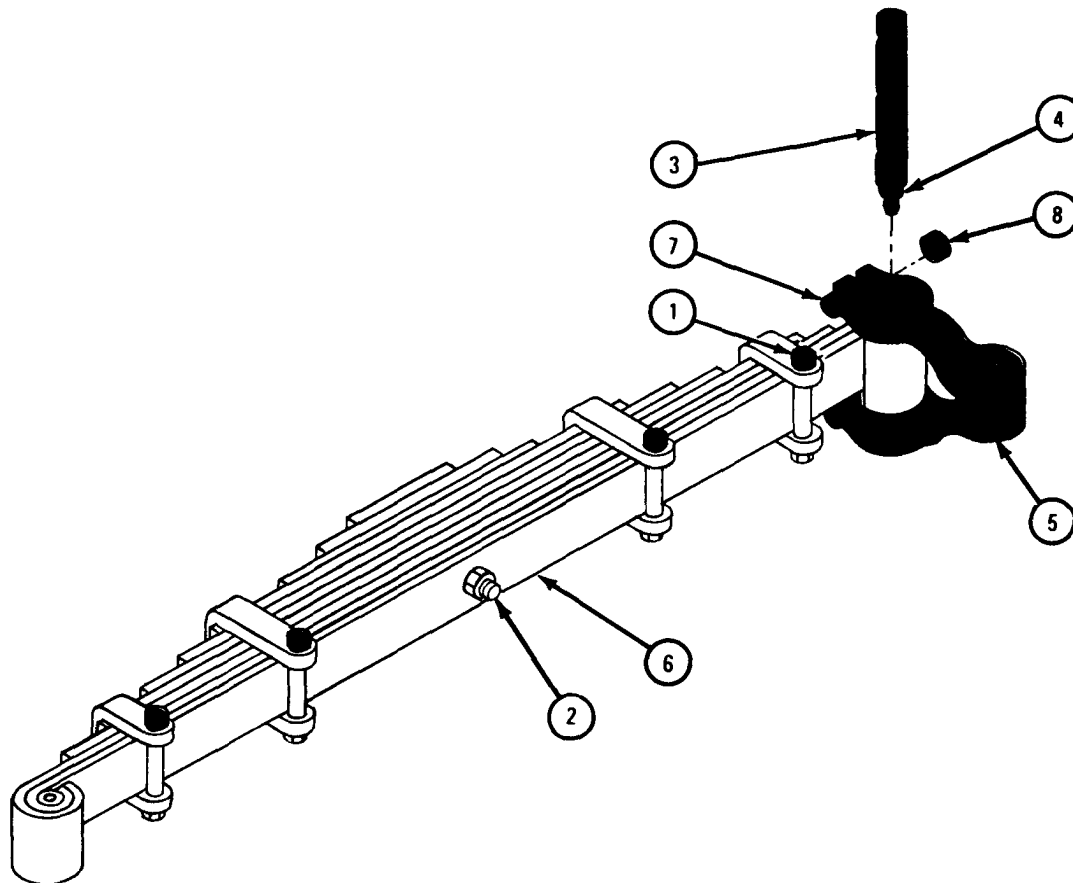

TA 046332

17-5. FRONT SPRING SEAT REMOVAL AND REPLACEMENT.

TOOLS: 5/8-inch wrench (2) Torque wrench, 600 pound-feet capacity
 1 1/16-inch wrench Strap wrench
 Jack 1 1/16-inch socket

SUPPLIES: None

PERSONNEL: One

EQUIPMENT CONDITION: Truck parked, engine off, handbrake set, rear wheels chocked.

a. Preliminary Procedure. Jack up frame to take the weight off springs and put tires just above ground. Put safety jacks under frame. Refer to Part 1, para 11-3.

b. Removal.

FRAME 1

1. Put jack (1) under axle housing (2) as shown.
2. Using 5/8-inch wrenches, hold nut (3) and unscrew and take off nut (4). Using strap wrench, hold shock absorber (5). Using 5/8-inch wrench, unscrew and take off nut (3).
3. Take off retainer (6) and rubber bushing (7).
4. Push screw end of shock absorber (5) out of hole in plate (8). Take off rubber bushing (9) and retainer (10).

GO TO FRAME 2

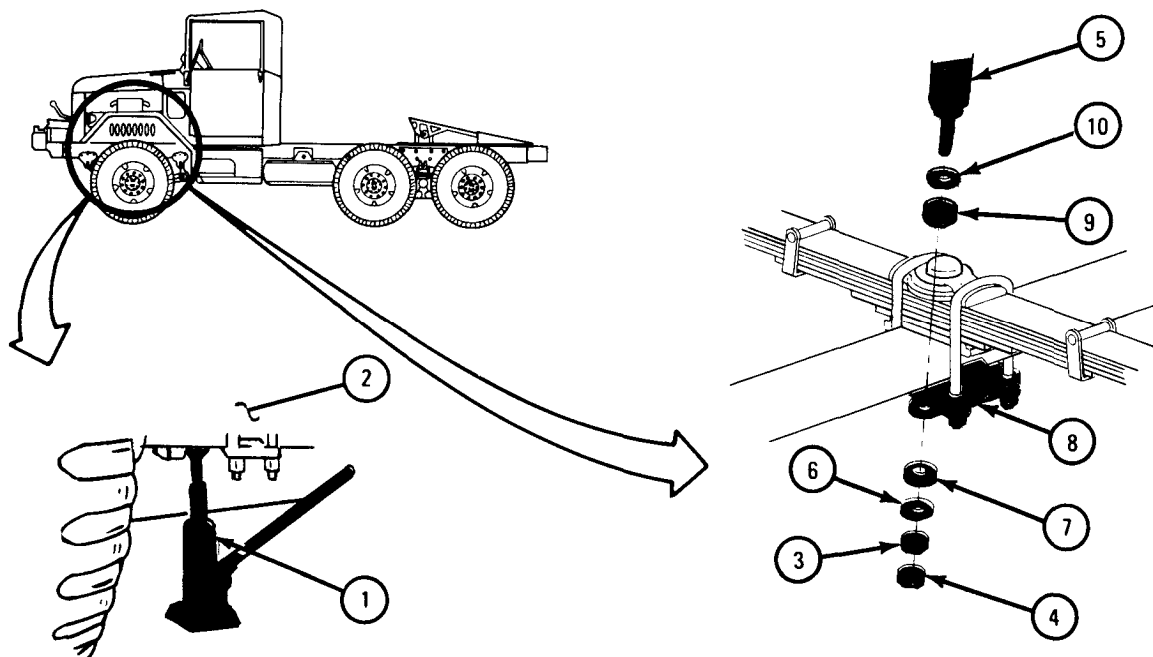

TA 046249.

FRAME 2

1. Using 1 1/16-inch wrench, unscrew and take off four nuts and lockwashers (1) from two U-bolts (2). Take off plate (3).
2. Lower jack until axle (4) drops below spring (5). Place safety jack under axle.
3. Take out spring seat (6).

CAUTION

Leave truck on safety jacks until spring seat is put back.

END OF TASK

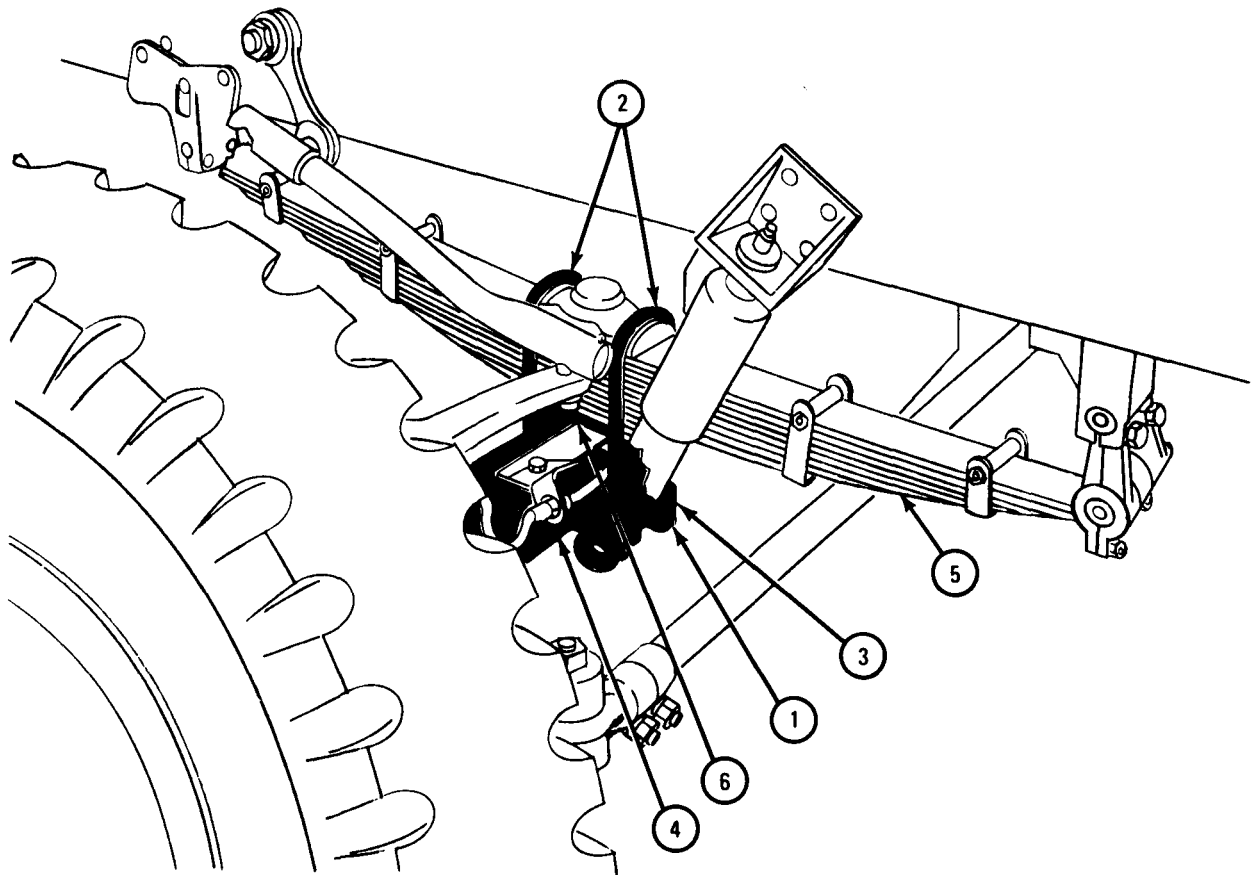

TA 046250

c. Replacement.

FRAME 1

1. Put spring seat (1) in place on axle housing (2).
2. Raise jack (3) under axle housing (2) until spring (4) just touches spring seat (1).
3. Put plate (5) on U-bolts (6) with hole for shock absorber toward back of truck. Put four lockwashers on two U-bolts and using 1 1/16-inch wrench, screw on and tighten four nuts (7).
4. Using torque wrench with 1 1/6-inch socket, tighten nuts (7) to 170 to 180 pound-feet.

GO TO FRAME 2

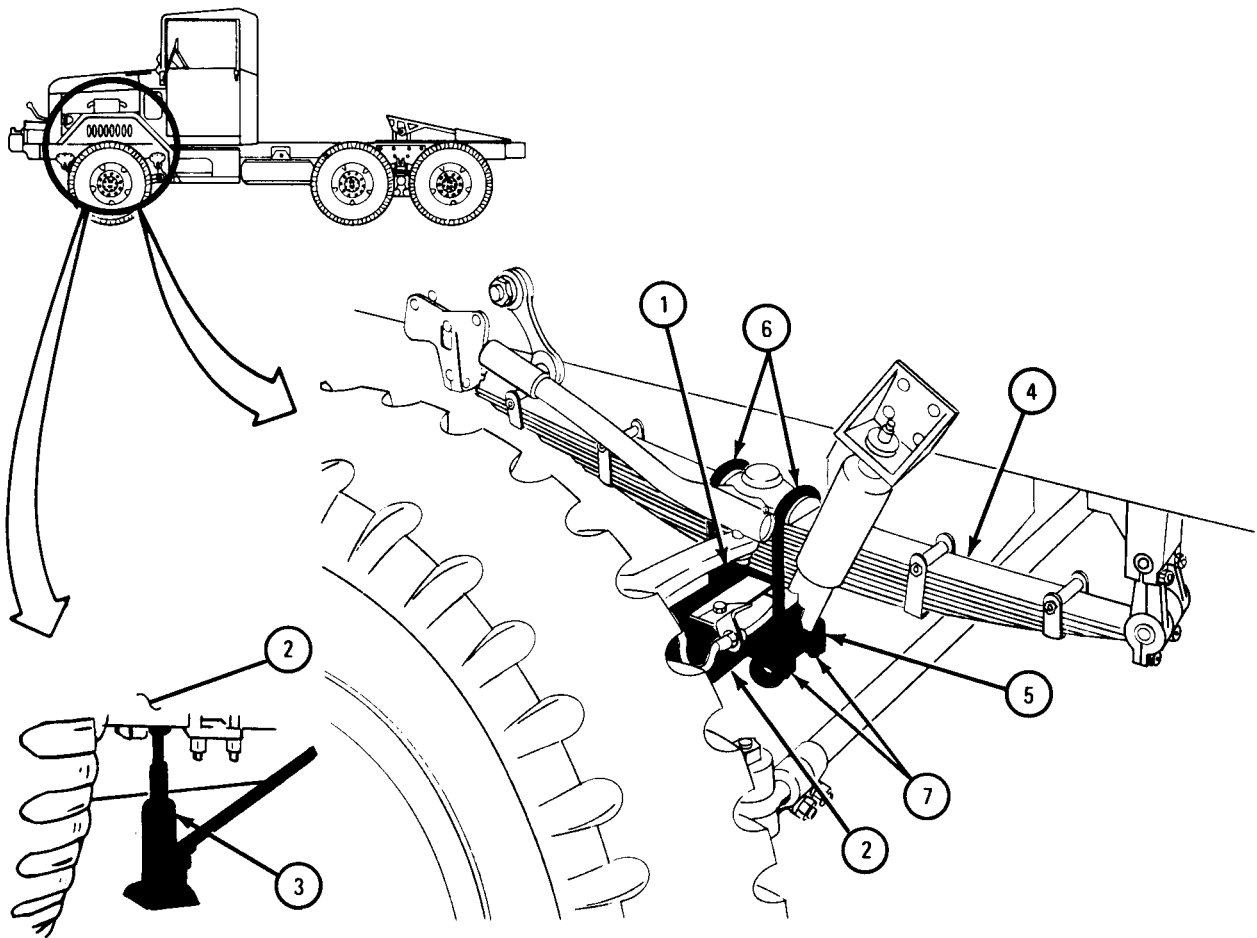

TA 046251

FRAME 2

1. Put retainer (1) and rubber bushing (2) on screw end of shock absorber (3). Pull screw end of shock absorber down into hole in plate (4).
2. Put on rubber bushing (5) and retainer (6). Using strap wrench, hold shock absorber (3). Using 5/8-inch wrench, screw on and tighten nut (7). Using 5/8-inch wrenches, hold nut (7) and screw on and tighten nut (8).

NOTE

Follow-on Maintenance Action Required:

Take out safety jacks. Jack truck down. Refer to Part 1, para 11-3.

END OF TASK

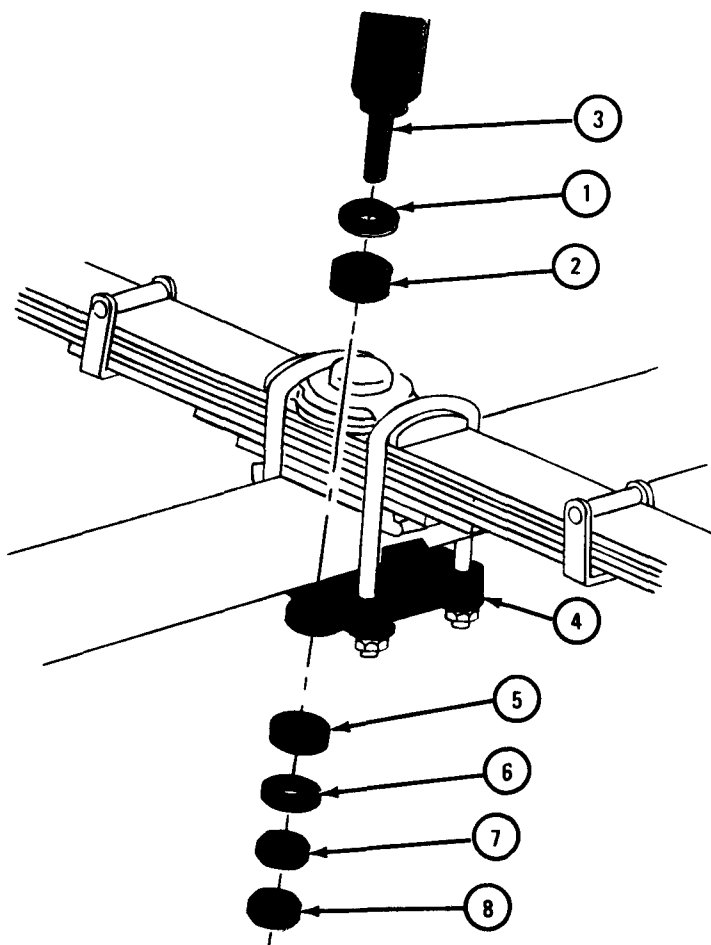

TA 101546

17-6. REAR SPRING REMOVAL AND REPLACEMENT.

NOTE

This task is shown for the left rear spring.
This task is the same for the right rear spring.

TOOLS: 1 1/16-inch open end wrench
Torque wrench, 600 pound-feet capacity
Tire iron

SUPPLIES: None

PERSONNEL: Two

EQUIPMENT CONDITION: Truck parked, engine off, handbrake set, wheels chocked.

a. Preliminary Procedures.

(1) Jack up left and right side of truck until spring ends just move off seats on axle housing and place jack stands under trunnion shaft. Refer to Part 1, para 11-3.

(2) Remove wheels from both axles and put jack stands under axle housing. Refer to TM 9-2320-209-10.

b. Removal.**FRAME 1**

1. Using 1 1/16-inch wrench, unscrew nuts (1) from both ends of U-bolts (2) in two places. Take off four nuts and four lockwashers (3).
2. Take off U-bolts (2) in two places.
3. Take off saddle (4).

GO TO FRAME 2

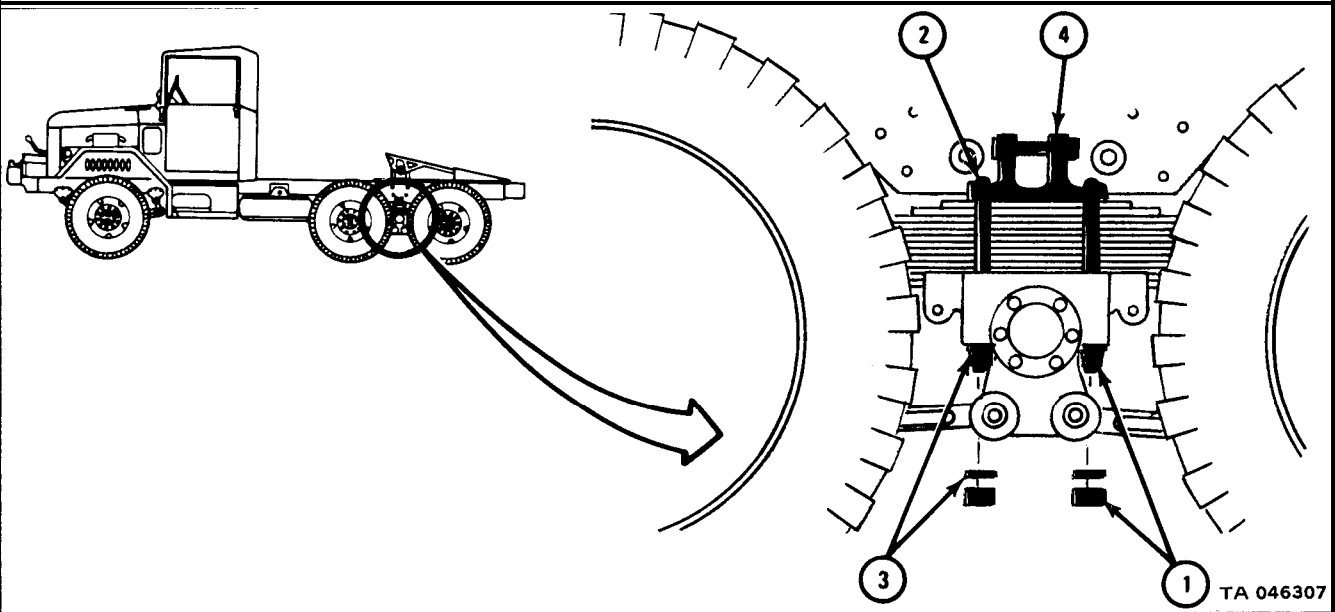

FRAME 2

WARNING

Spring is heavy. Make sure spring does not fall and cause injury to personnel and damage equipment.

Soldiers 1. Slide spring (1) toward rear of truck until it is out of front spring A and B guide (2). Take off spring.

END OF TASK

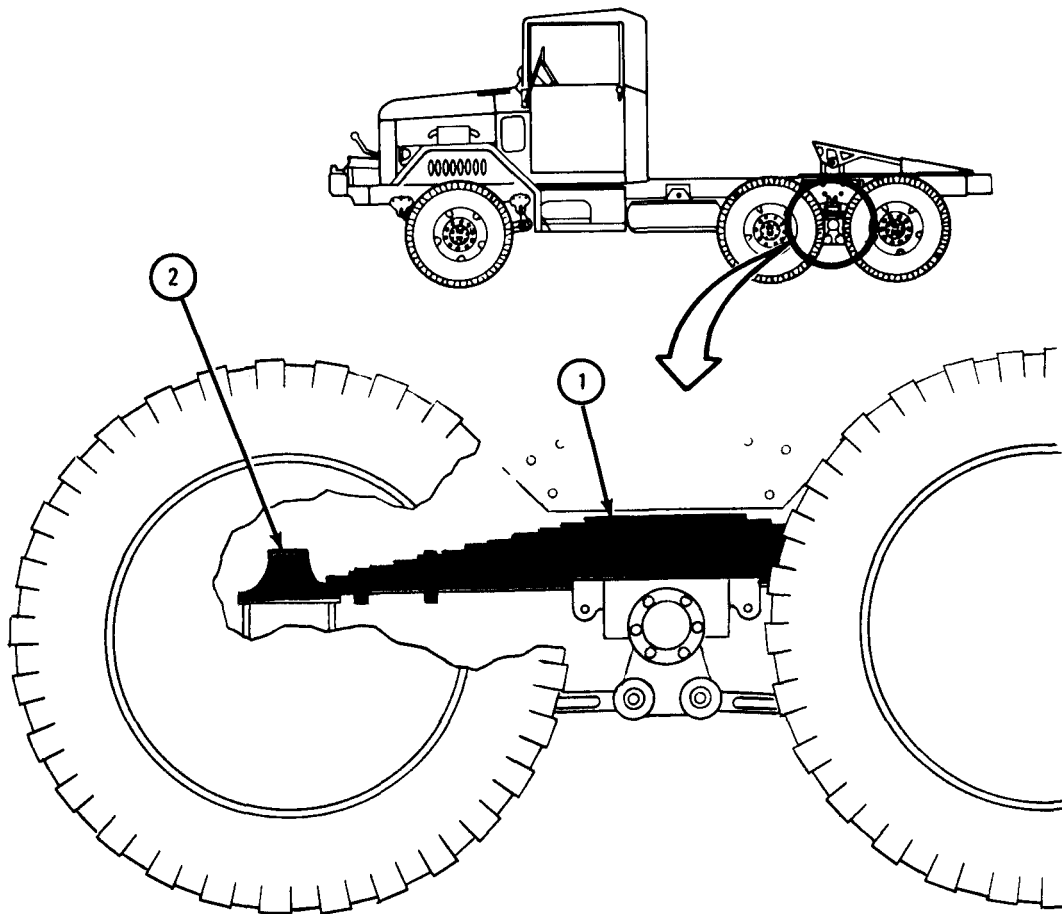

TA 046439

c. Replacement.WARNING

Spring is heavy. Make sure spring does not fall and cause injury to personnel and damage equipment.

FRAME 1

- Soldiers 1. Put spring (1) in place so that front of spring is in spring guide A and B (2) and rear of spring rests on axle housing (3).
2. Slide spring to the front and back into rear spring seat (4).

GO TO FRAME 2

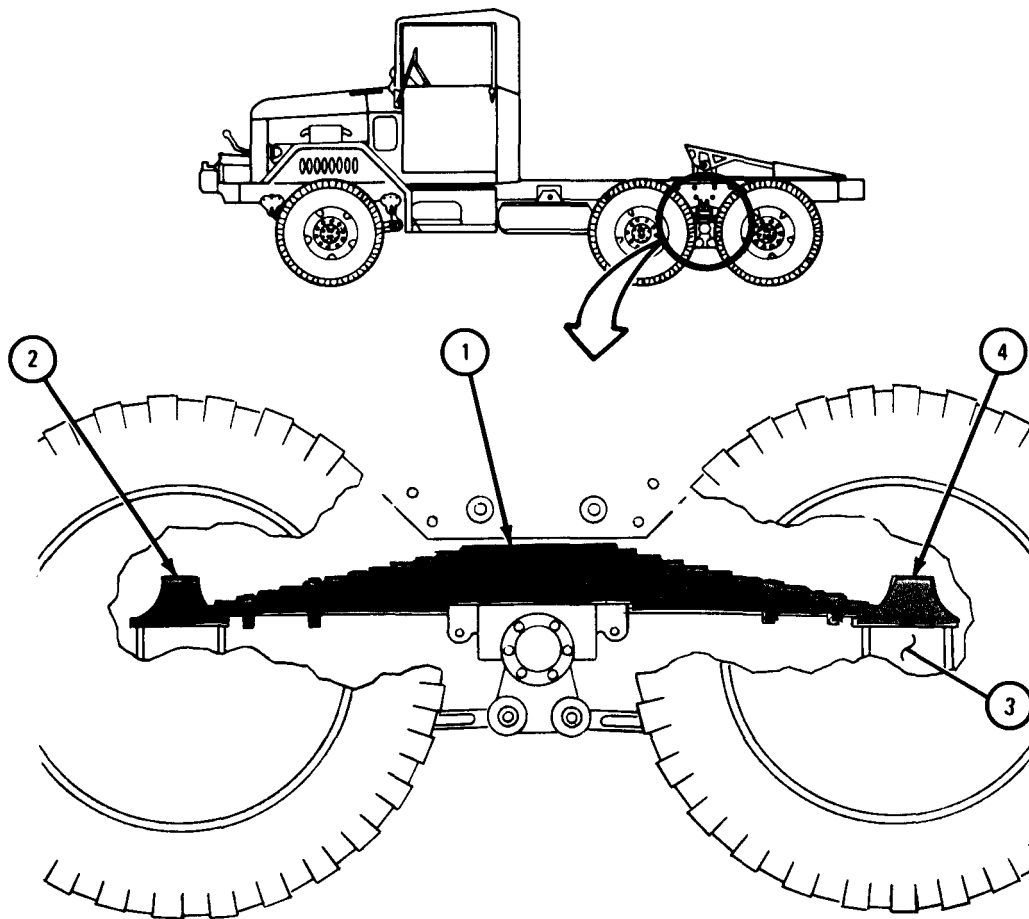

TA 046309

FRAME 2

WARNING

Spring is heavy. Make sure spring does not fall and cause injury to personnel and damage to equipment.

1. Put spring (1) in place so spring seat (2) is in middle of spring and spring is down on spring seat.
2. Put saddle (3) on spring (1). Put U-bolts (4) over saddle and through spring seat (2) in two places.
3. Put lockwashers (5) and nuts (6) on U-bolts (4) in two places. Using torque wrench, tighten nuts to 190 to 230 pound-feet.

NOTE

Follow-on Maintenance Action Required:

1. Replace wheels. Refer to TM 9-2320-209-10.
2. Jack up truck. Take safety jacks away. Jack truck down. Refer to Part 1, para 11-3

END OF TASK

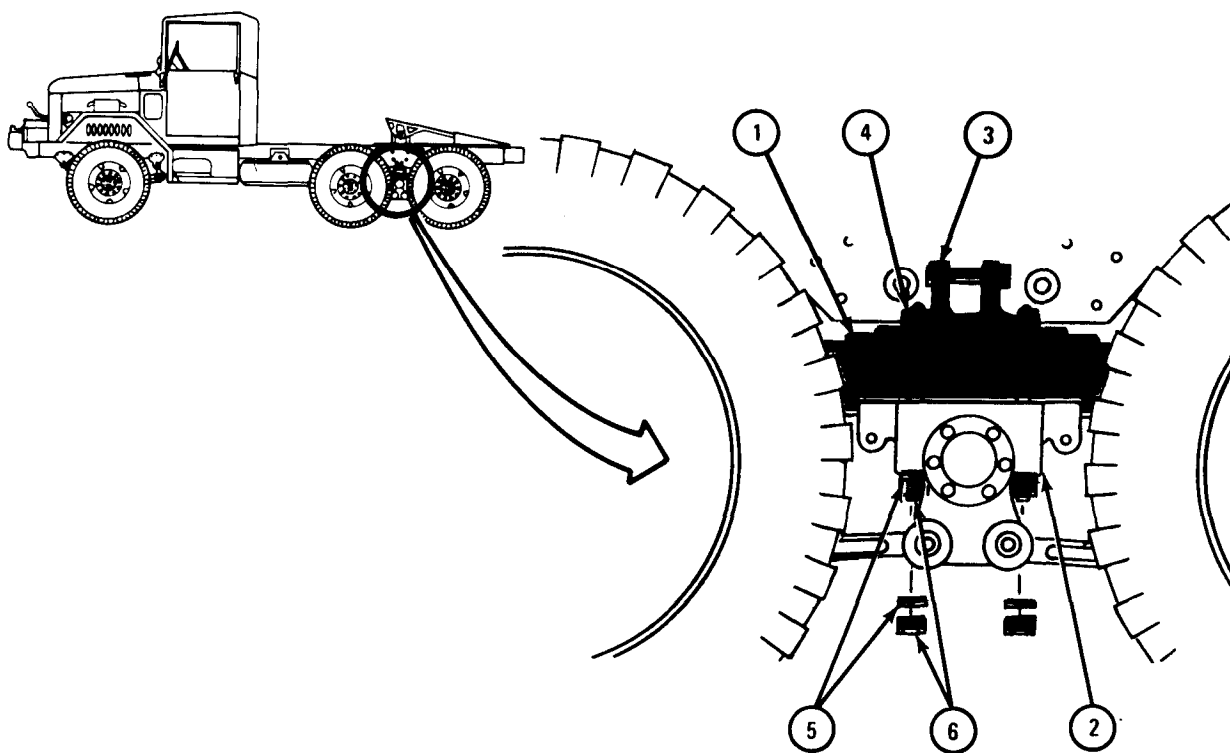

TA 046443

17-7. REAR LEAF SPRING ASSEMBLY REPAIR.

TOOLS: File
 9/16-inch wrench (2)
 11/16-inch wrench (2)
 Wire brush
 Ballpeen hammer
 C-clamp

SUPPLIES: Solvent, dry cleaning, type II (SD-2), Fed. Spec P-D-680
 Powdered graphite, SS-G-659A

PERSONNEL: One

EQUIPMENT CONDITION: Truck parked, engine off, handbrake set.

a. Preliminary Procedures.

- (1) Jack up and support truck. Refer to Part 1, para 11-3.
- (2) Remove rear leaf spring from truck. Refer to para 17-6.

NOTE

Only the longest three leaves of spring may be replaced. Throw away any spring that has other leaves damaged.

b. Disassembly.

FRAME 1

1. Using file, file off peened over ends of four screws (1).

GO TO FRAME 2

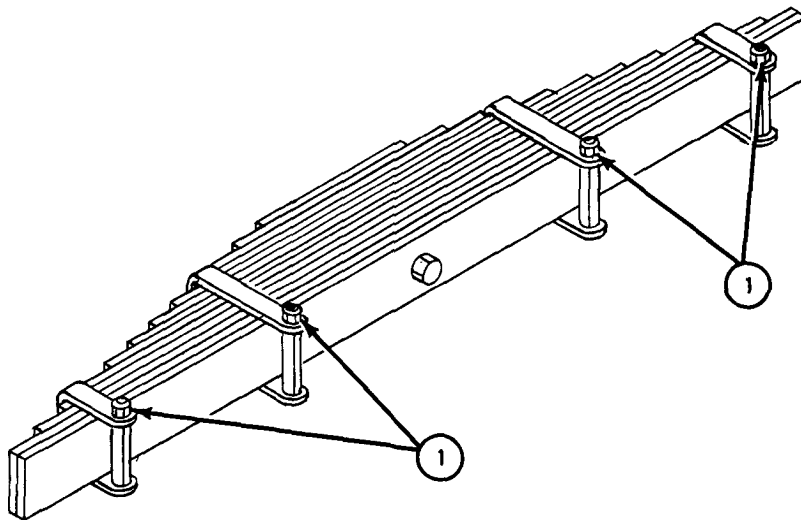

TA 046320

FRAME 2

WARNING

Springs are under tension. Be careful to avoid injury when taking spring apart.

1. Put C-clamp (1) in place on spring (2) as shown and tighten C-clamp.
2. Using 9/16-inch wrenches, unscrew and take off four screws (3) and four nuts (4). Throw away screws and nuts.
3. Take off four spacers (5).

NOTE

Spring comes apart when nut (6) is unscrewed.

4. Using 11/16-inch wrenches, carefully unscrew and take off screw (7) and nut (6).
5. Throw away screw (7) and nut (6).
6. Carefully unscrew C-clamp (1) and take it off spring (2).

END OF TASK

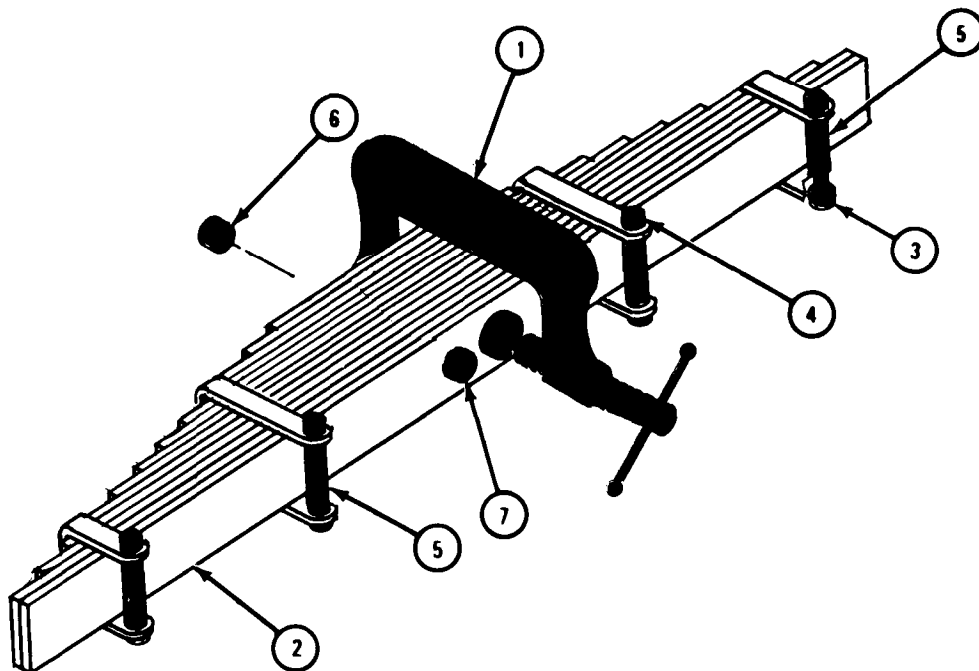

TA 046321

c. Cleaning, Inspection, and Repair.

FRAME 1

WARNING

Dry cleaning solvent is flammable. Do not use near an open flame. Keep a fire extinguisher nearby when solvent is used. Use only in well-ventilated places. Failure to do this may result in injury to personnel and damage to equipment.

NOTE

Only the longest three leaves of spring may be replaced. Throw away any spring that has other leaves damaged.

1. Clean all parts with solvent. Check all spring leaves in spring assembly (1) for cracks and breaks. Check four spacers (2) and four clips (3) for damage or wear.
2. Using wire brush, clean off any rust or corrosion on spring leaves in spring (1).
3. Throw away damaged parts. Get new parts in their place.

END OF TASK

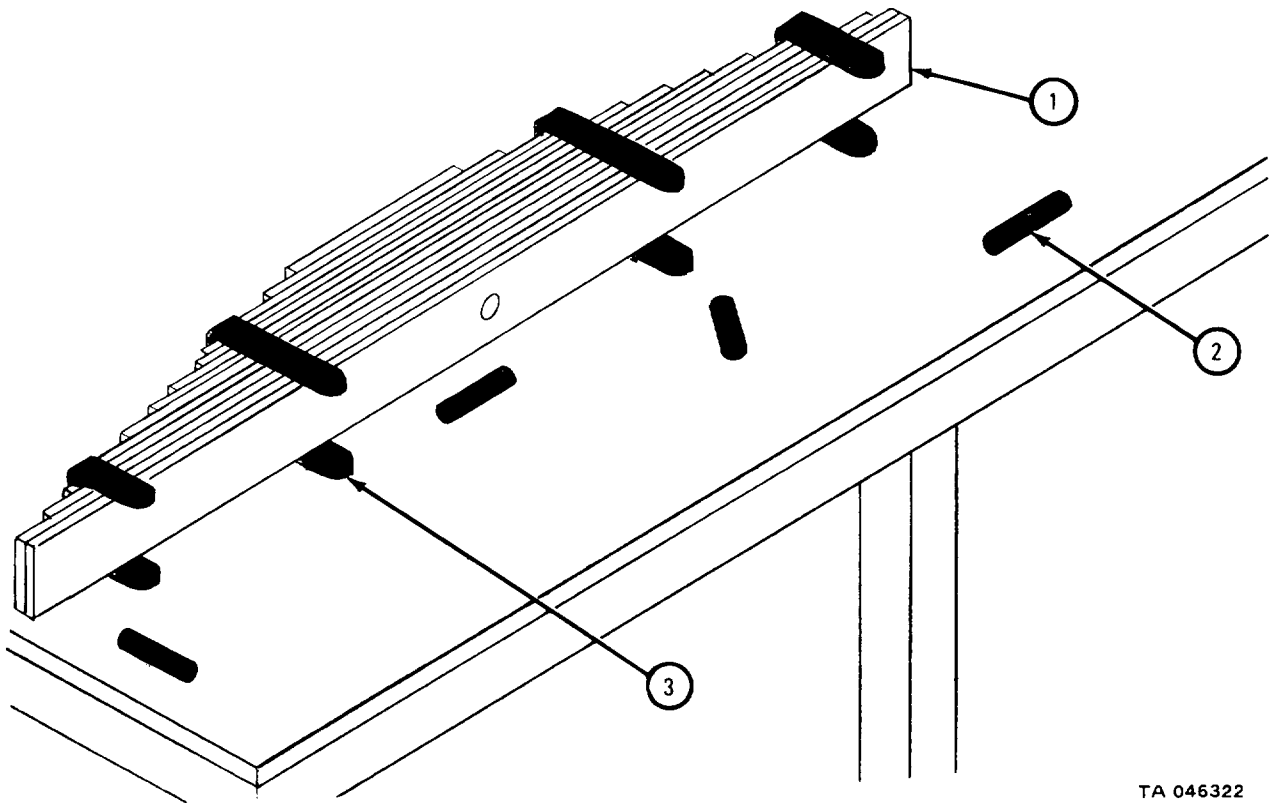

TA 046322

d. Assembly.

FRAME 1

1. Put screw (1) into hole in spring leaf (2). Put a small amount of powdered graphite on spring leaf on side where screw comes out.

NOTE

Some trucks do not have spring leaf (3). This task is still the same for all trucks.

2. Keep stacking the other 11 spring leaves on screws (1), putting powdered graphite between each layer. Always put larger spring leaf on before next smaller one.

GO TO FRAME 2

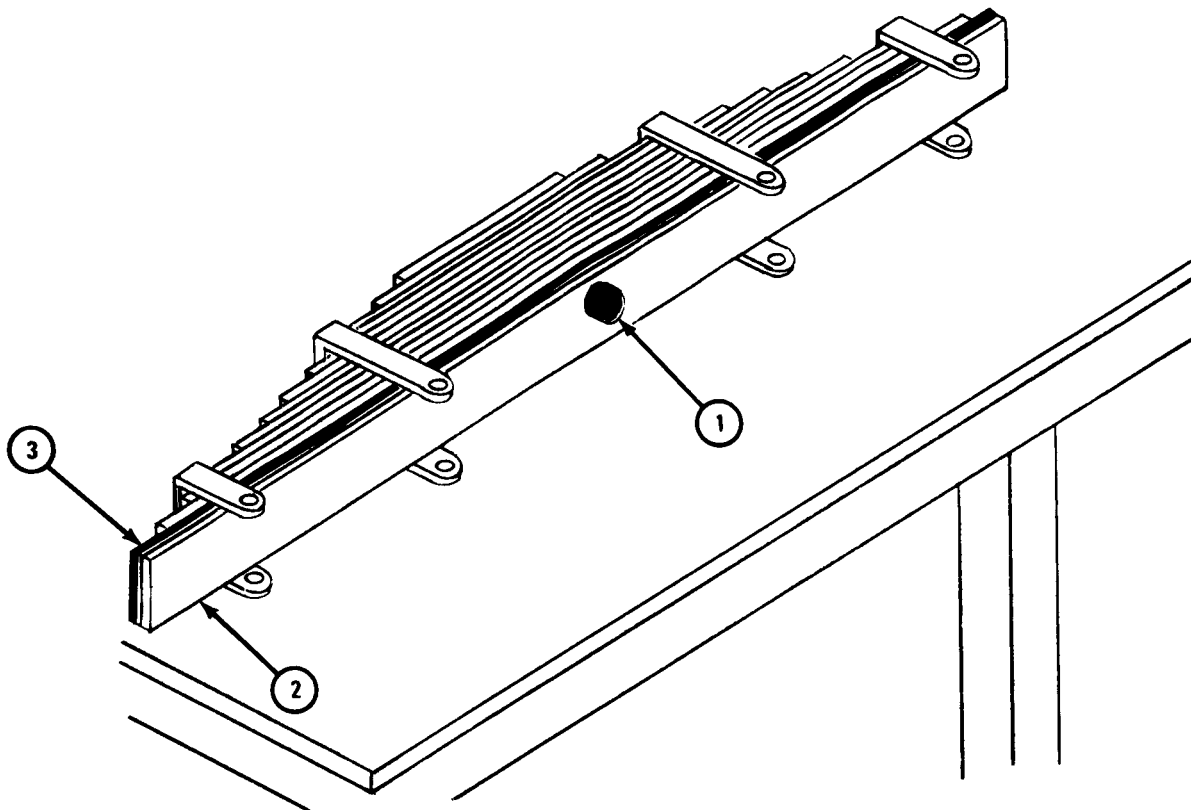

TA 046323

FRAME 2

1. Put C-clamp (1) on spring (2). Turn handle on C-clamp to squeeze spring leaves together.
2. Using 11/16-inch wrenches, screw on and tighten screw (3) and nut (4). Unscrew and take off C-clamp (1).
3. Put four spacers (5) in four clips (6) and align holes.
4. Using 9/16-inch wrenches, screw on and tighten four screws (7) and four nuts (8) in four spacers (5) and four clips (6). Do not overtighten nuts. Clips should not bind spring (2).
5. Using hammer, peen over ends of five screws (3 and 7).

NOTE

Follow-on Maintenance Action Required:

1. Replace rear leaf spring in truck. Refer to para 17-6.
2. Lower truck and take away jack. Refer to Part 1, para 11-3.

END OF TASK

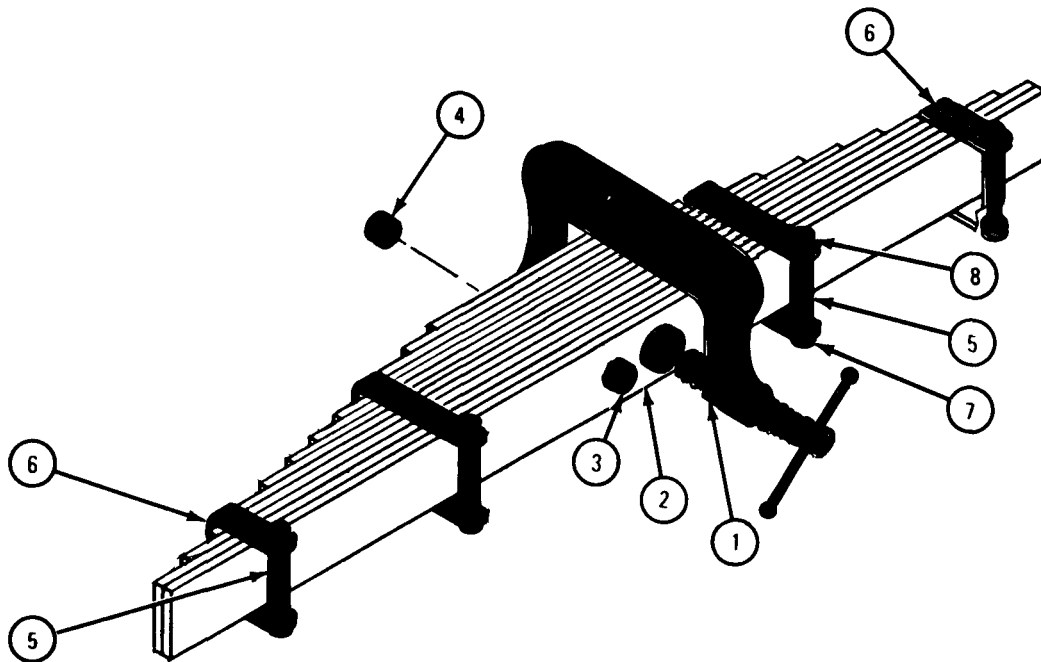

TA 101547

17-8. REAR SPRING SEAT REMOVAL AND REPLACEMENT.

- | | |
|--|--|
| <p>TOOLS:</p> <ul style="list-style-type: none"> 1/2-inch wrench 1 1/16-inch wrench Jack (2) Flat-tip screwdriver Replacer, pn C-10937827 Torque wrench, 600 pound-foot capacity | <ul style="list-style-type: none"> Punch Needle nose pliers Wheel bearing nut wrench, pn 7076869 Lubricator bearing packer Jack stand (2) |
|--|--|

- SUPPLIES:
- Cover gasket
 - Nut lock
 - Artillery and automotive grease, type GAA, MIL-G-10924
 - Rag

PERSONNEL: One

EQUIPMENT CONDITION: Truck parked, engine off, handbrake set, front wheels chocked.

a. Preliminary Procedures.

(1) Jack up rear of truck and remove rear wheels. Refer to TM 9-2320-209-10.

(2) Put safety jacks under axle housings. Jack truck down onto safety jacks. Jack up cross shaft near spring seat until jack holds. Refer to Part 1, para 11-3.

b. Removal.

FRAME 1

1. Using 1/2-inch wrench, unscrew and take out six screws (1) and lockwashers (2).
 2. Take off cover (3) and gasket (4). Throw gasket away.
- GO TO FRAME 2

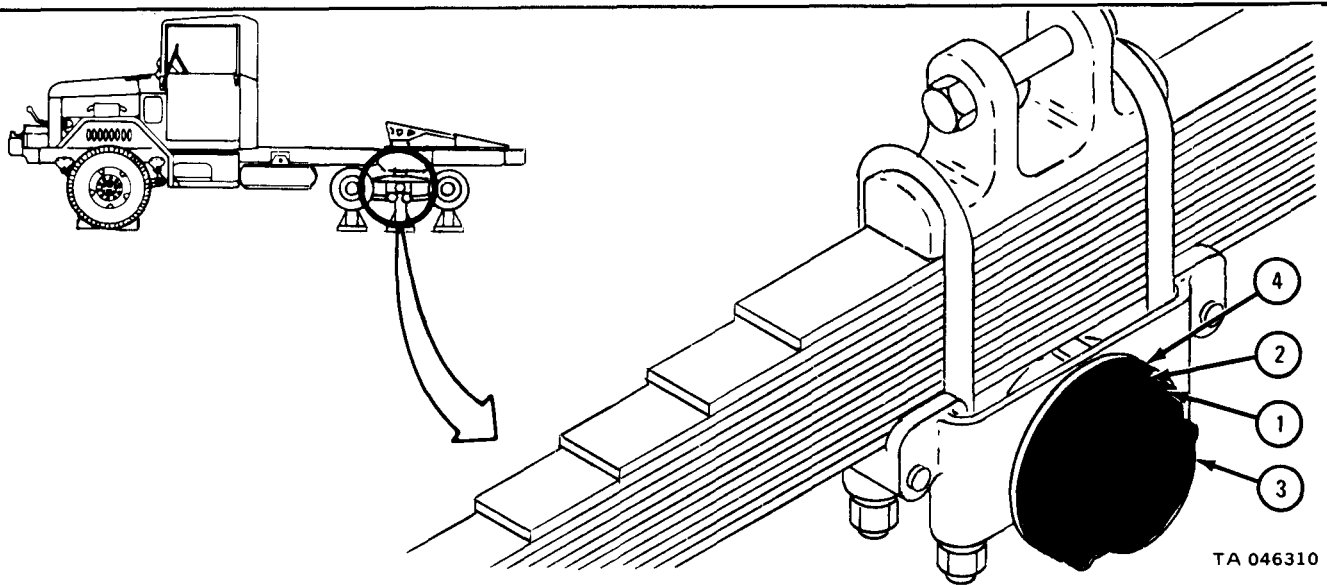

FRAME 2

1. Using 1 1/16-inch wrench, unscrew and take off four nuts (1) from both ends of U-bolts (2). Take off four lockwashers (3).
2. Take off two U-bolts (2) and U-bolt saddle (4).
3. Using punch, straighten tab of nut lock (5). Using 3-inch wheel bearing nut wrench, unscrew and take off outer locknut (6) and nut lock (5). Throw nut lock away.

GO TO FRAME 3

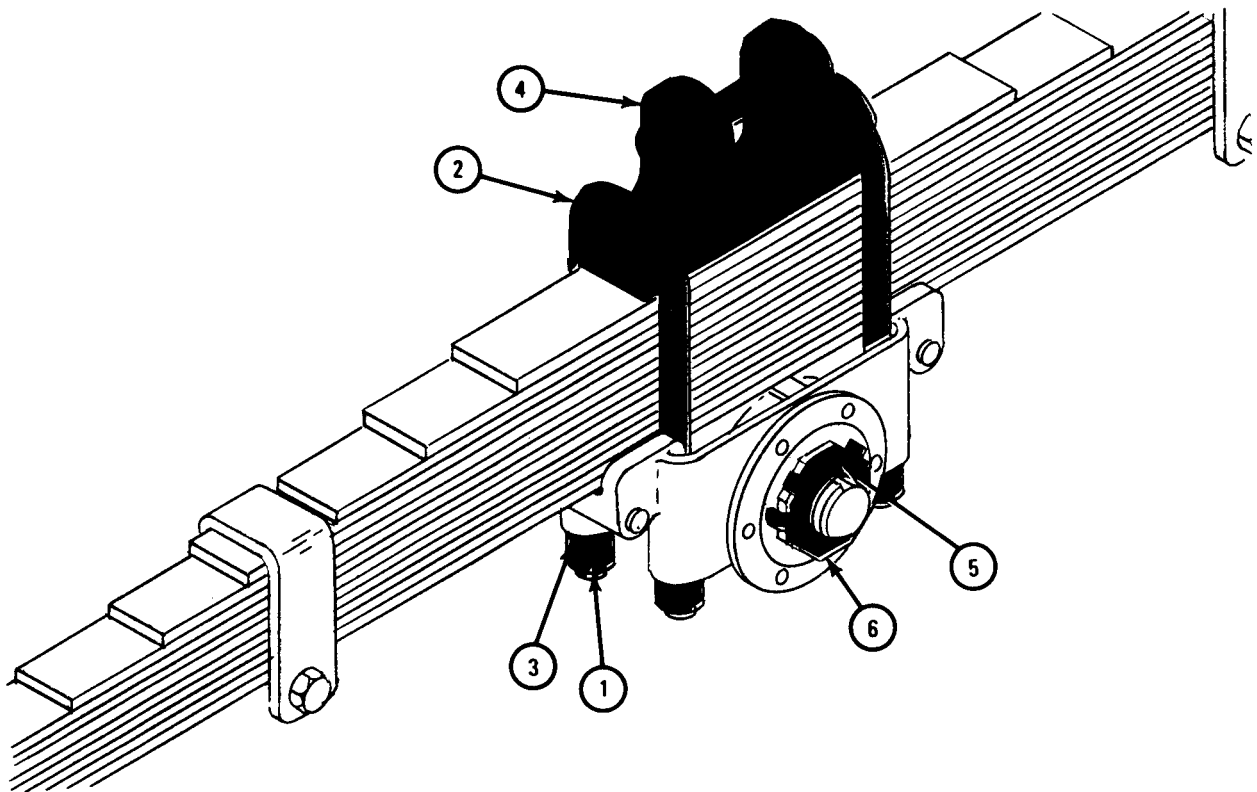

TA 046311

FRAME 3

1. Put jacks under spring (1) on both sides of spring seat (2). Jack spring up off spring seat. Put jack stands under spring.
2. Using wheel bearing nut wrench, unscrew and take off nut (3). Take out outer bearing (4).
3. Take off spring seat (2).
4. Take off inner bearing (5).

NOTE

Leave all jacks in place until spring seat is put back on.

END OF TASK

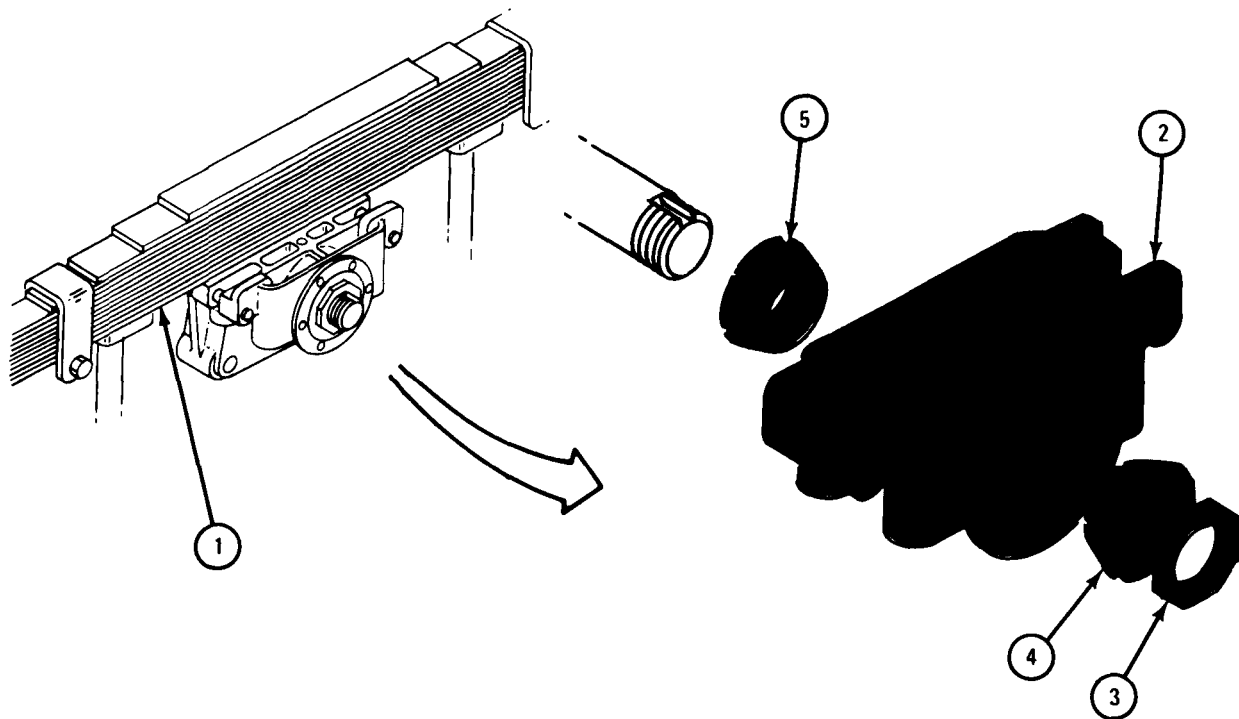

TA 046312

c. Replacement.

NOTE

If new seals are not needed, start with frame 2.

If new seals are needed, start with frame 1.

FRAME 1

1. Using screwdriver, pry seal (1), retainer (2), felt seal (3), and washer (4) off shaft (5). Be careful not to bend washer or retainer. Throw seal (1) and felt seal (3) away.
2. Put washer (4) onto shaft (5). Fit felt seal (3) onto lip of retainer (2) and put them on shaft with felt seal toward truck. Put seal (1) onto shaft with rubber away from truck.
3. Using replacer, push parts (1, 2, 3, and 4) into place.

GO TO FRAME 2

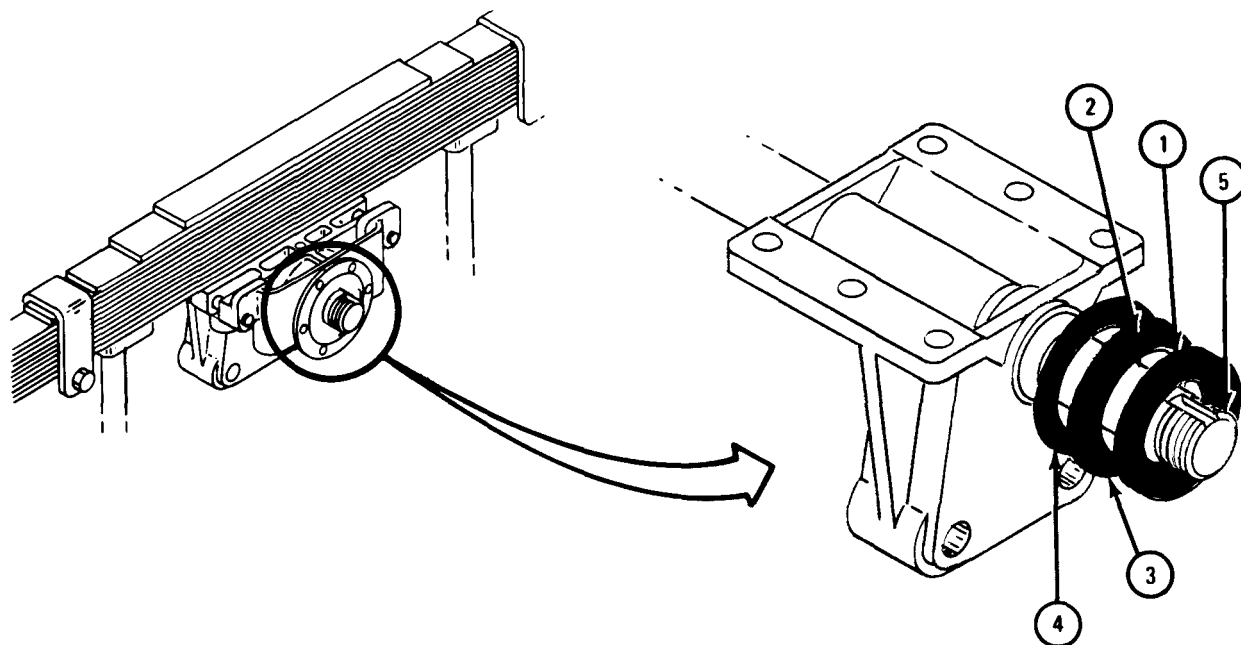

TA 046313

FRAME 2

1. Coat inside of spring seat (1) with grease.
2. Using lubricator bearing packer, pack bearings (2 and 3) with grease.
3. Put inner bearing (2) on shaft (4).
4. Put spring seat (1) on shaft (4).
5. Put outer bearing (3) over shaft (4) and into spring seat (1).
6. Screw on inner wheel bearing nut (5). Using torque wrench, tighten nut to 60 to 75 pound-feet. Using 3-inch wheel bearing nut wrench, unscrew nut 1/4 turn.

GO TO FRAME 3

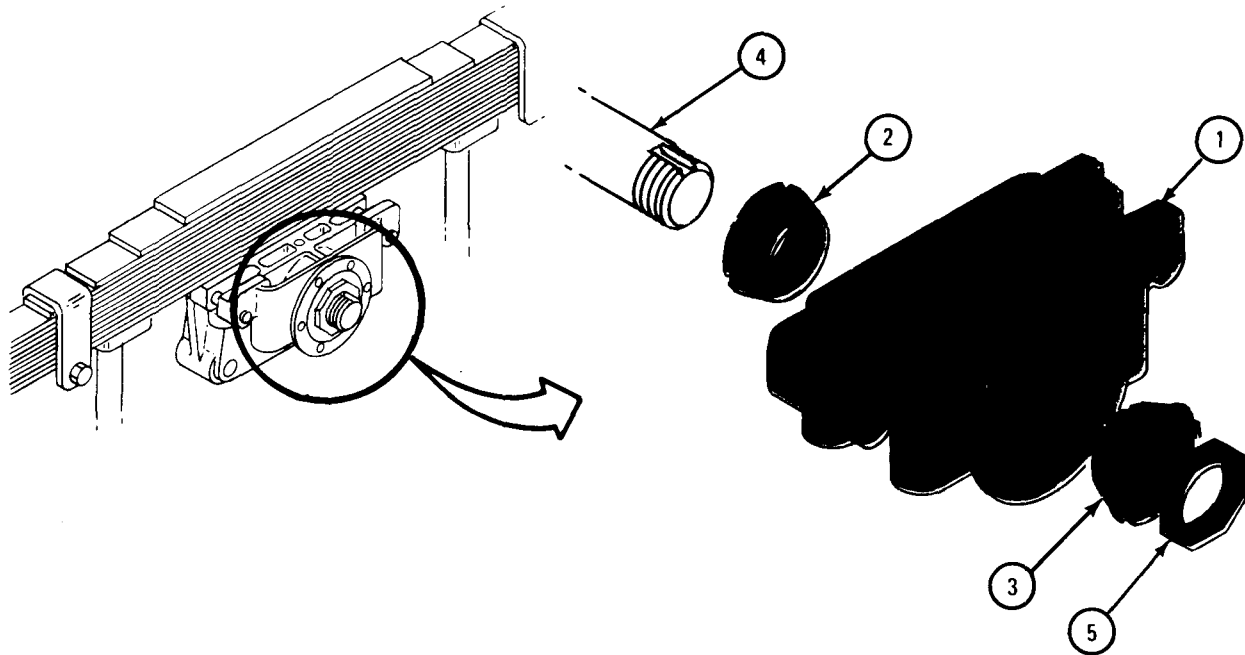

TA 046314

FRAME 3

1. Put nut lock (1) on shaft (2). Tab on nut lock must be in keyway of shaft.
2. Screw on locknut (3). Using torque wrench, tighten locknut to 150 pound-feet.
3. Using punch, bend tab of nut lock (1) over a flat on locknut (4).
4. Using punch, bend tab of nut lock (1) over a flat on locknut (3).

GO TO FRAME 4

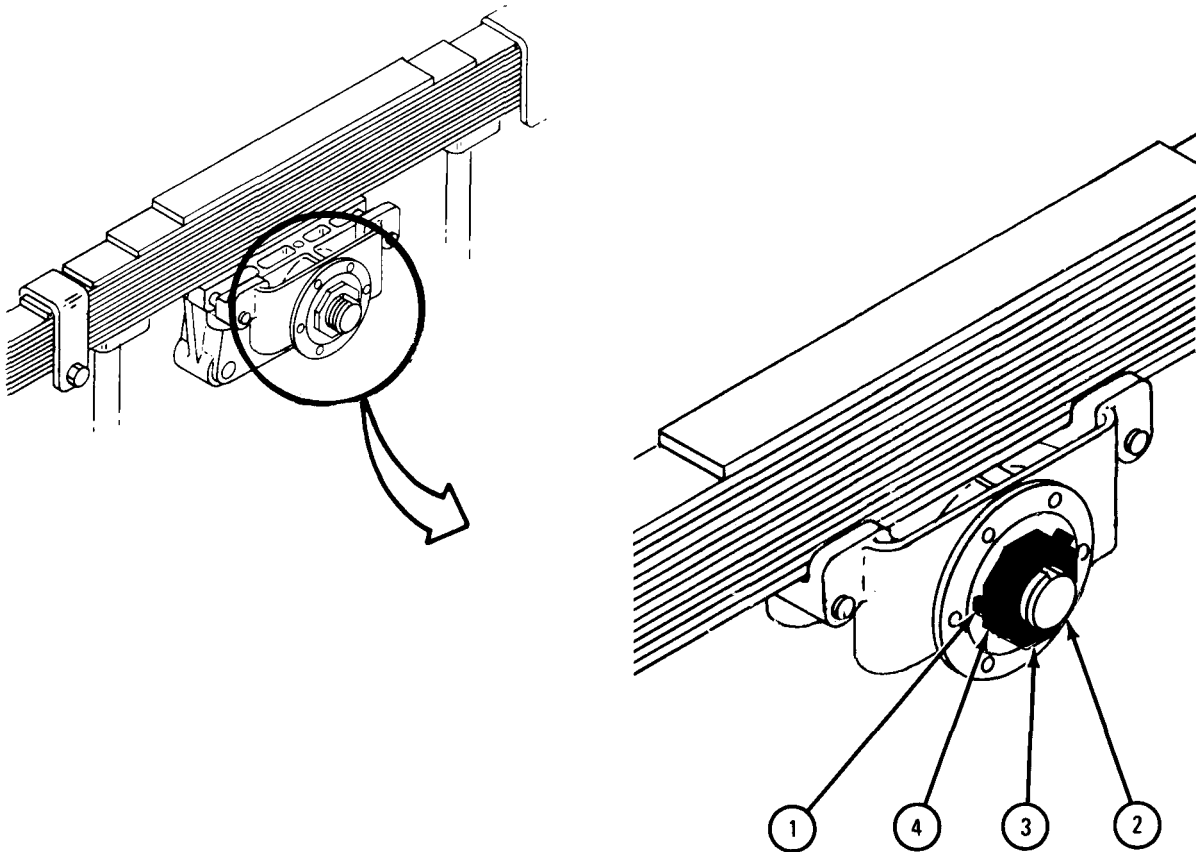

TA 046315

FRAME 4

1. Pack cover (1) with grease. Grease both sides of gasket (2). Put gasket on cover, lining up screw holes.
2. Put cover (1) with gasket (2) onto spring seat (3), lining up screw holes. Put lockwashers (4) onto screws (5) and, using 1/2-inch wrench, screw in and tighten six screws.
3. Using torque wrench, tighten screws (5) to 16 to 20 pound-feet.
4. Using rag, clean away any grease that squeezed out.
5. Jack spring (6) down until it just touches spring seat (3).

GO TO FRAME 5

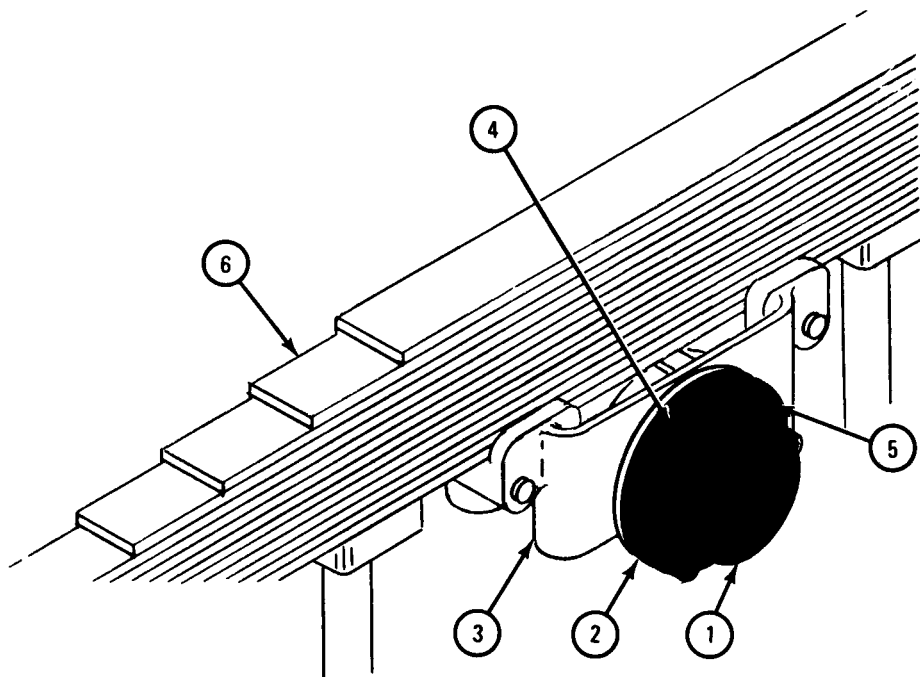

TA 046316

FRAME 5

1. Put saddle (1) onto spring (2). Make sure saddle is down on spring. Put U-bolts (3) over saddle and down into spring seat (4).
2. Put lockwashers (5) and screw nuts (6) onto U-bolts (3).
3. Lower jacks (7) from spring (2) and take jacks away.
4. Using torque wrench, tighten nuts (6) to 180 to 230 pound-feet.

NOTE

Follow-on Maintenance Action Required:

1. Replace rear wheels. Refer to TM 9-2320-209-10.
2. Lower and take away jacks under cross shaft and axle housing. Refer to Part 1, para 11-3.

END OF TASK

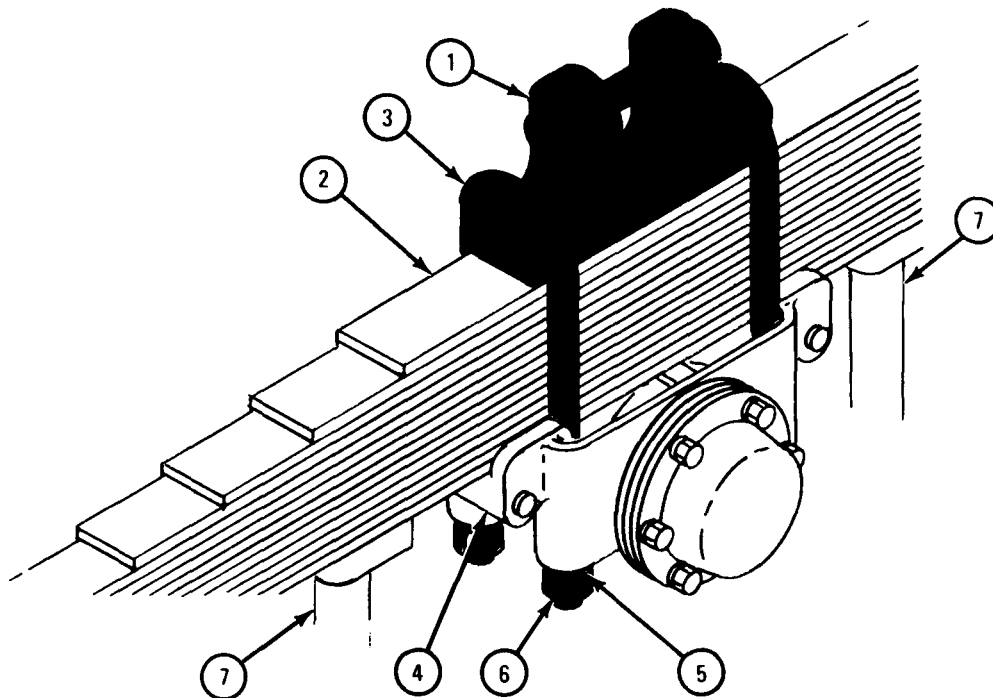

TA 046317

17-9. REAR SPRING SEAT REPAIR.

NOTE

This task is for removal and replacement of bearing cups. The task is the same for removal and replacement of the solid adapter bushings.

TOOLS: Hammer
Remover and replacer, pn 7082863
Screw, pn 7083216

SUPPLIES: Solvent, dry cleaning, type II (SD-2), Fed. Spec P-D-680
Rag
Artillery and automotive grease, type GAA, MIL-G-10924
Plywood, 1 x 12 x 12 inches, with 5-inch hole to clear spring seat cups

PERSONNEL: One

EQUIPMENT CONDITION: Truck parked, engine off, handbrake set.

a. Preliminary Procedures.

(1) Take rear spring seat off truck. Refer to para 17-8.

WARNING

Dry cleaning solvent is flammable. Do not use near an open flame. Keep a fire extinguisher nearby when solvent is used. Use only in well-ventilated places. Failure to do this may result in injury to personnel and damage to equipment.

(2) Using rag wet with solvent, clean cross shaft where spring seat was. Check cross shaft for damage. Tell direct support about damage.

b. Disassembly.

FRAME 1

1. Push both halves of remover and replacer tool (1) together so there is no space between them.
2. Put remover and replacer tool (1) inside bore of spring seat (2) so it is on top of lower bearing cup (3). Pry remover and replacer tool open.
3. Turn screw (4) all the way into remover and replacer tool (1). Put spring seat (2) on plywood (5) so bearing cup (3) will come down into hole in plywood.
4. Using hammer, hammer on screw (4) to drive out bearing cup (3). Lift up spring seat (2) so screw (4) falls out. Take out and throw away bearing cup.
5. Unscrew screw (4) from remover and replacer tool (1). Turn spring seat (2) over so other bearing cup is down.
6. Do steps 1 through 4 again on other bearing cup.

WARNING

Dry cleaning solvent is flammable. Do not use near an open flame. Keep a fire extinguisher nearby when solvent is used. Use only in well-ventilated places. Failure to do this may result in injury to personnel and damage to equipment.

7. Clean all parts in solvent and dry them. Check all parts for damage or wear, and get new parts for ones that are damaged or worn.

END OF TASK

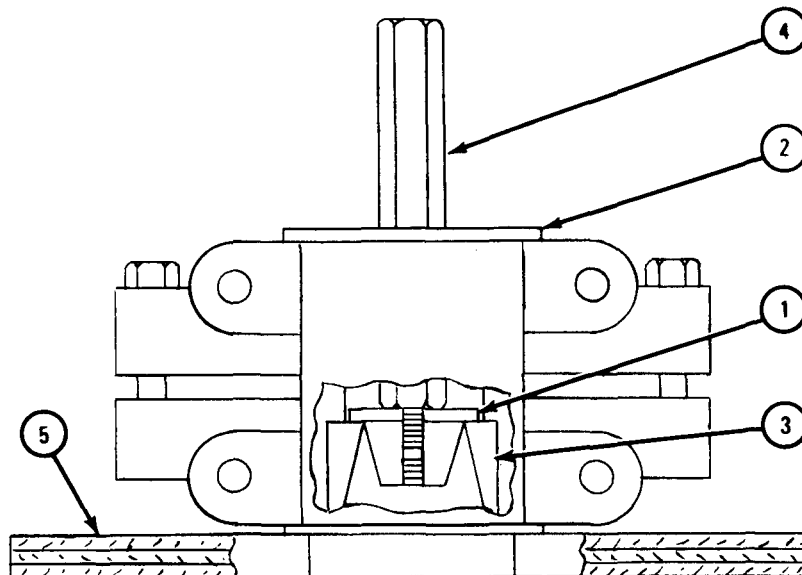

TA 046318

c. Assembly.

FRAME 1

1. Using finger, put thin film of grease in bore of spring seat (1) where bearing cups (2) will go. Put spring seat on plywood (3) to keep spring seat from getting damaged.
2. Put bearing cup (2) on bore in spring seat (1) with thin edge of bearing cup facing up.
3. Put remover and replacer tool (4) in bearing cup (2). Spread open remover and replacer tool and turn screw (5) all the way in.
4. Using hammer, hammer on screw (5) until bearing cup (2) is seated.
5. Turn spring seat (1) over so bearing cup (2) is down.
6. Do steps 1 through 4 again on other bearing cup.

NOTE

Follow-on Maintenance Action Required:

Put rear spring seat back on truck. Refer to para 17-8.

END OF TASK

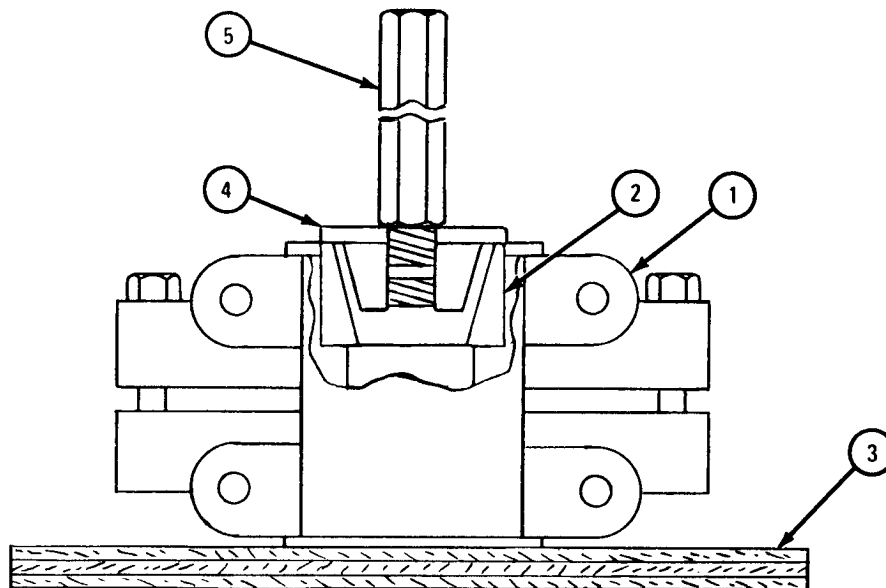

TA 046319

17-10. REAR SPRING SEAT WITH BEARINGS REMOVAL AND REPLACEMENT.

TOOLS: 1/2-inch wrench
 1 1/16-inch wrench
 Torque wrench, 600 pound-
 feet capacity
 Flat-tip screwdriver
 Needle nose pliers

Brass punch
 Jack (2)
 Wheel bearing remover and replacer,
 pn 7082863
 Oil seal replacer, pn C-10937827
 Jack stand (2)

SUPPLIES: Cover gasket
 Nut lock
 Artillery and automotive grease, type GAA, MIL-G-10924
 Rag

PERSONNEL: One

EQUIPMENT CONDITION: Truck parked, engine off, handbrake set, front wheels chocked.

a. Preliminary Procedures.

- (1) Jack up and support rear axle housings. Refer to Part 1, para 11-3.
- (2) Remove rear wheels. Refer to TM 9-2320-209-10.
- (3) Put jack under cross shaft and support it.

b. Removal.

FRAME 1

1. Using 1/2-inch wrench, unscrew and take out six screws (1) and lockwashers (2).
 2. Take off cover (3) and gasket (4). Throw away gasket.
- GO TO FRAME 2

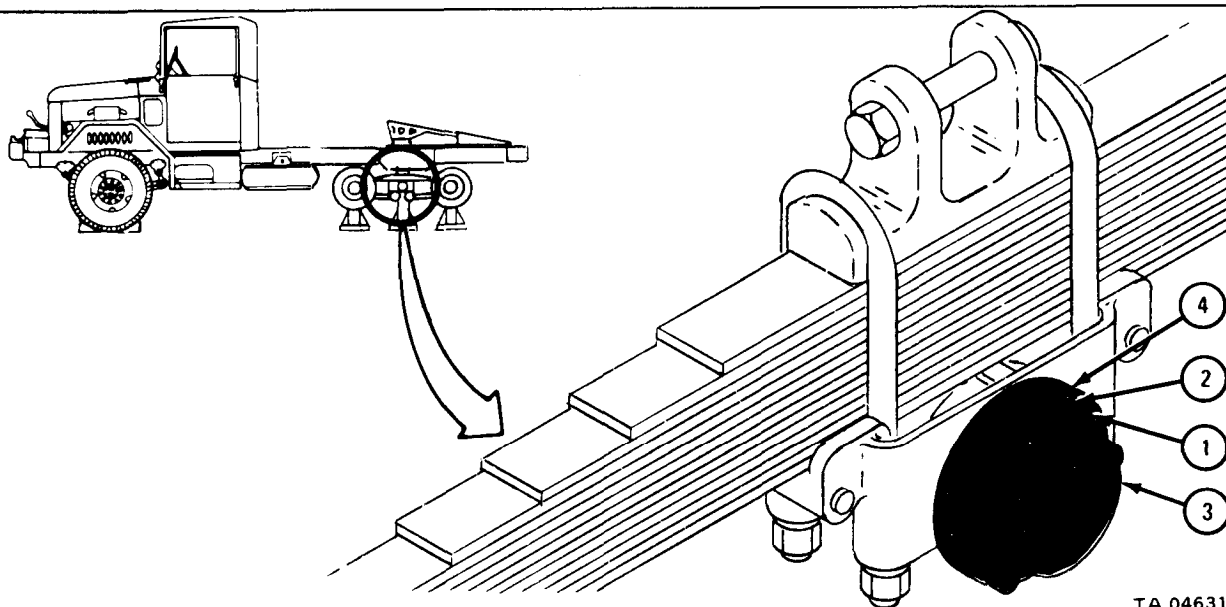

TA 046310

FRAME 2

1. Using 1 1/16-inch wrench, unscrew and take off four nuts (1) from ends of two U-bolts (2). Take off four lockwashers (3).
2. Take off two U-bolts (2) and U-bolt saddle (4).
3. Using punch, straighten tab of nut lock (5). Using wheel bearing remover, unscrew and take off outer locknut (6) and nut lock (5). Throw away nut lock.

GO TO FRAME 3

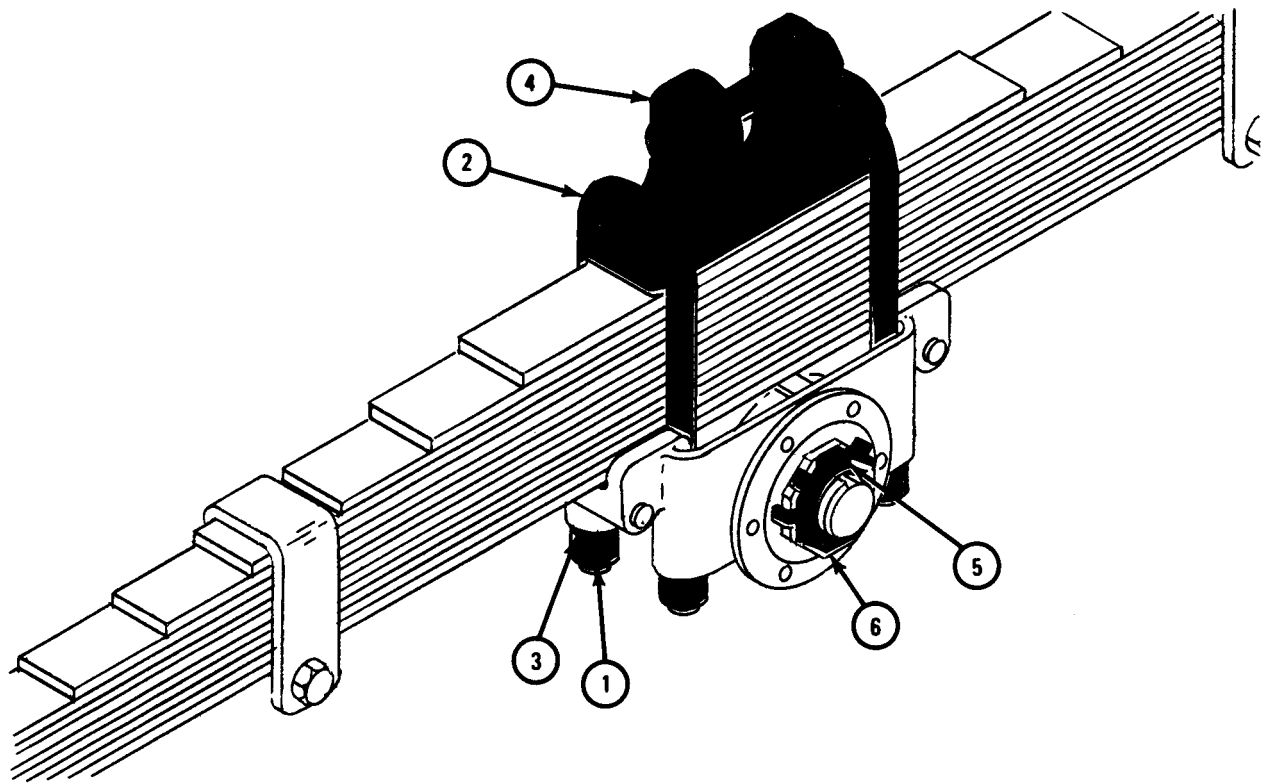

TA 046311

FRAME 3

1. Lower jack under cross shaft until spring seat (1) is free of spring (2).
2. Using wheel bearing remover, unscrew and take off nut (3). Take out outer bearing (4).
3. Take off spring seat (1).
4. Take out inner bearing (6).

END OF TASK

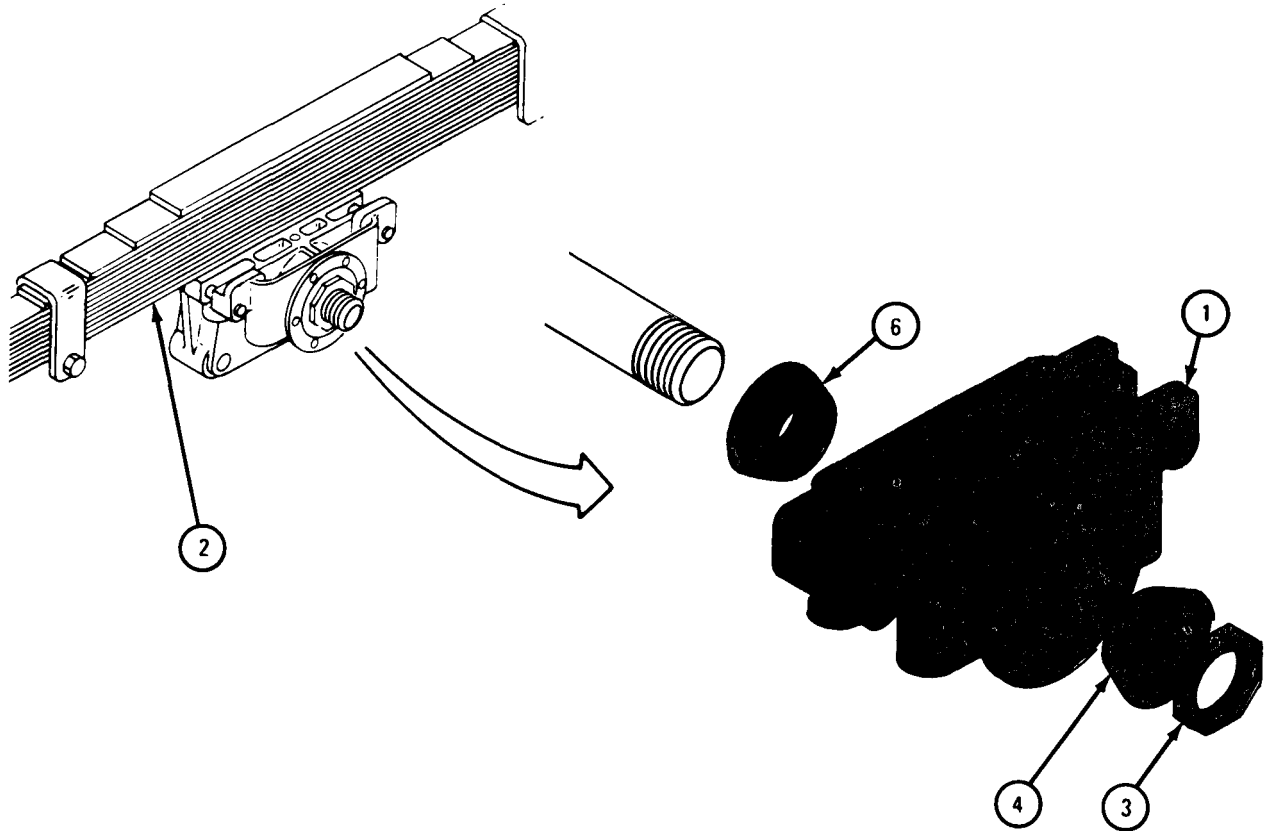

TA 101595

c. Replacement.

FRAME 1

1. Using screwdriver, pry seal (1), retainer (2), felt seal (3), and washer (4) off shaft (5). Be careful not to bend washer or retainer. Throw away seal (1) and felt seal (3).
2. Put washer (4) on shaft (5). Fit felt seal (3) onto lip of retainer (2) and put them on shaft with felt seal toward truck. Put seal (1) on shaft with rubber away from truck.
3. Using replacer, push parts (1, 2, 3, and 4) into place.

GO TO FRAME 2

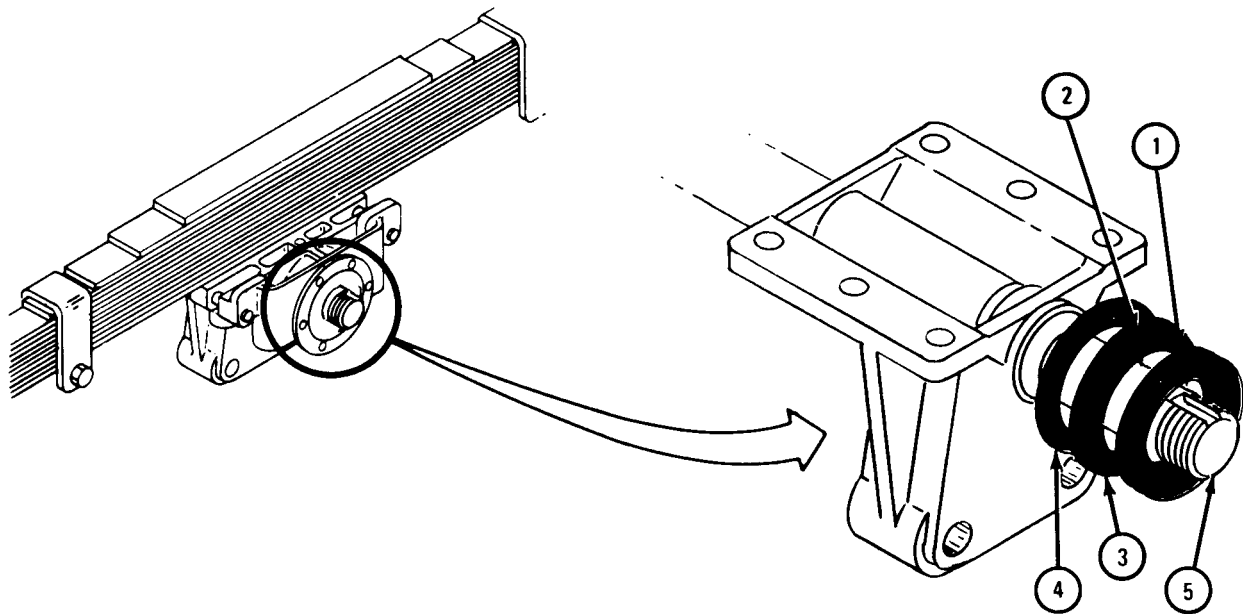

TA 102396

FRAME 2

1. Put a coat of grease on inside of spring seat (1).
2. Put inner bearing (2) in place.
3. Put spring seat (1) in place.
4. Put outer bearing (3) on shaft (4). Push bearing into spring seat (1).
5. Screw on adjusting nut (5). Using torque wrench, tighten adjusting nut to 60 to 75 pound-feet. Using wheel bearing replacer, unscrew adjusting nut 1/2 turn.

GO TO FRAME 3

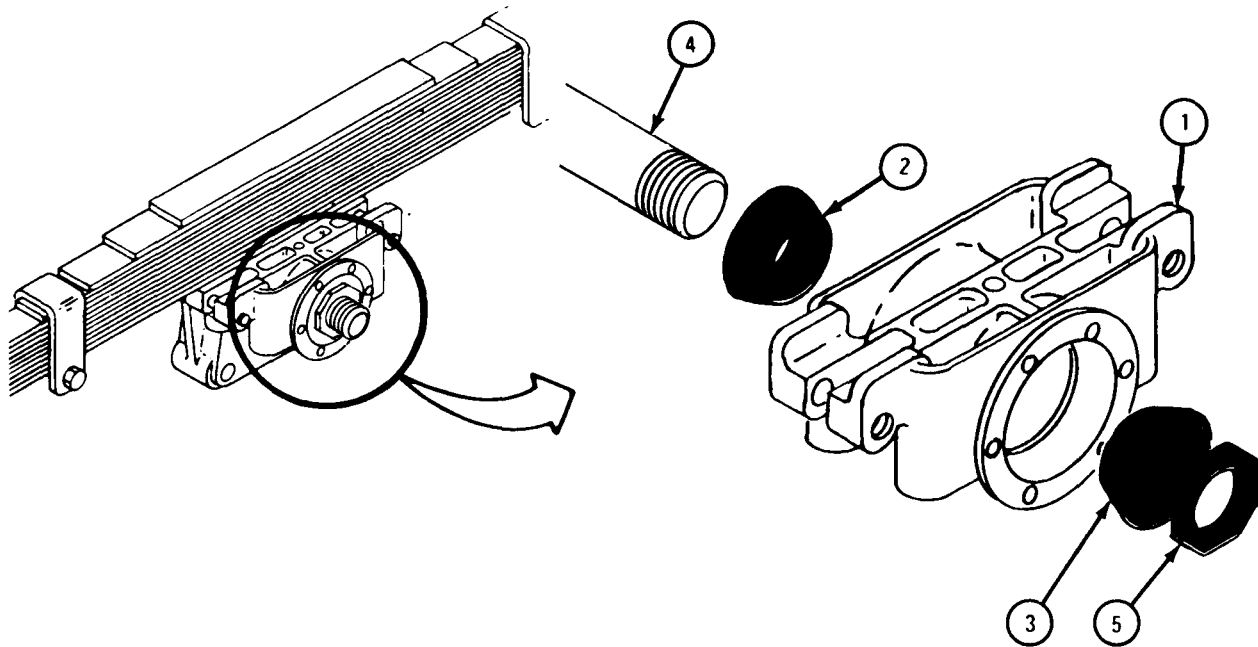

TA 101596

FRAME 3

1. Put nut lock (1) on shaft (2) with inner tab on nut lock in keyway of shaft.
2. Screw on locknut (3). Using torque wrench, tighten locknut to 150 pound-feet.
3. Using punch, bend tab of nut lock (1) over a flat on adjusting nut (4).
4. Using punch, bend tab of nut lock (1) over a flat on locknut (3).

GO TO FRAME 4

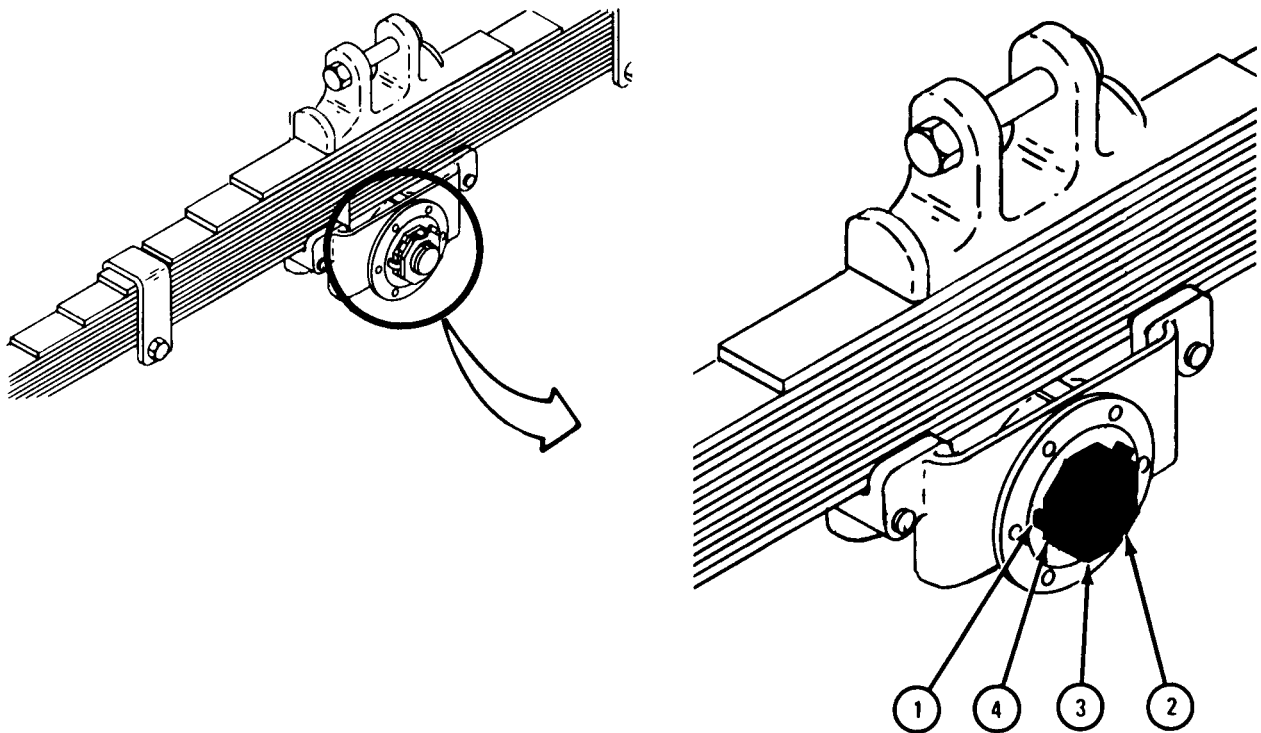

TA 102397

FRAME 4

1. Pack cover (1) with grease. Grease both sides of gasket (2). Put gasket on cover, lining up screw holes.
2. Put cover (1) with gasket (2) onto spring seat (3), lining up screw holes. Using 1/2-inch wrench, screw in and tighten six lockwashers (4) and screws (5).
3. Using torque wrench, tighten screws (5) to 16 to 20 pound-feet.
4. Using rag, clean off any grease that squeezed out.
5. Jack up cross shaft until spring seat (3) just touches spring (6).

GO TO FRAME 5

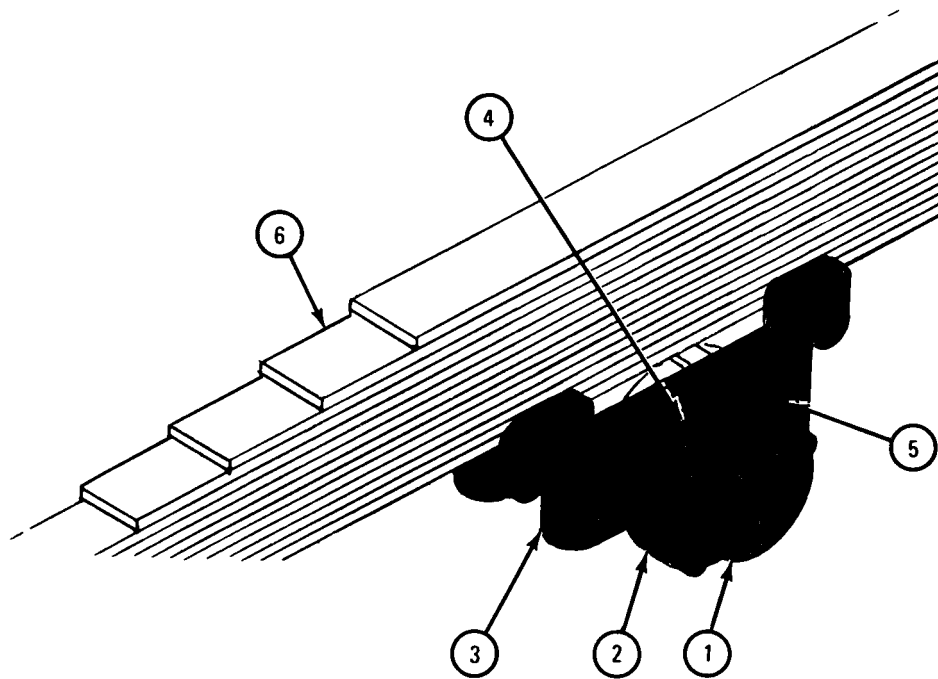

TA 102398

FRAME 5

1. Put saddle (1) onto spring (2). Make sure saddle is down on spring. Put U-bolts (3) over saddle and down into spring seat (4).
2. Screw on four lockwashers (5) and nuts (6) to U-bolts (3).
3. Using torque wrench, tighten four nuts (6) to 180 to 230 pound-feet.

NOTE

Follow-on Maintenance Action Required:

1. Replace rear wheels. Refer to TM 9-2320-209-10.
2. Lower and take away jacks under cross shaft and rear axle housings. Refer to para 11-3.
3. Remove chocks from front wheels.

END OF TASK

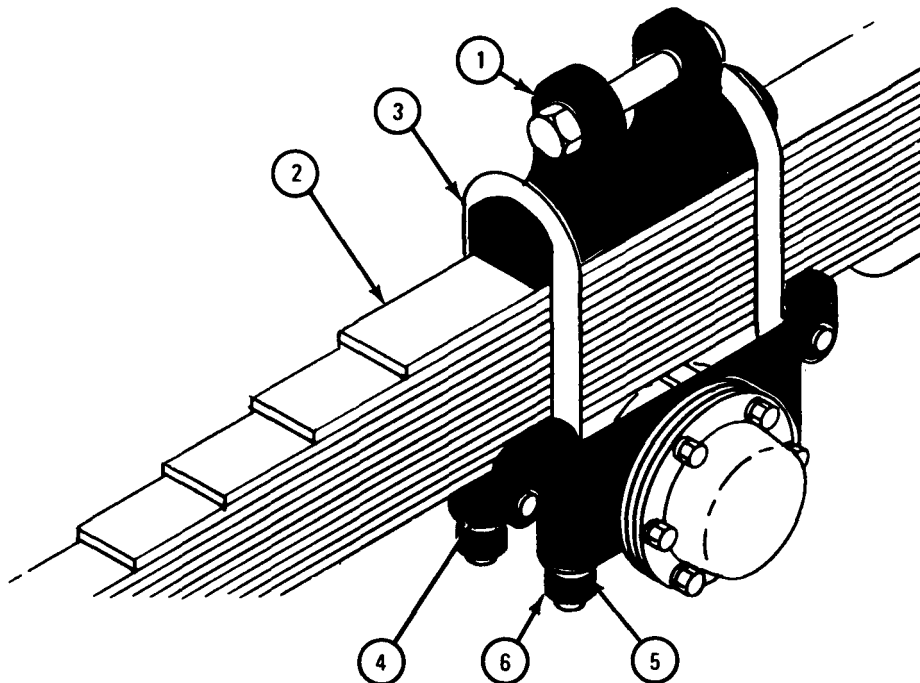

TA 102399

Section III. SHOCK ABSORBERS

17-11. SHOCK ABSORBER REMOVAL AND REPLACEMENT.

TOOLS: 5/8-inch wrench

SUPPLIES: None

PERSONNEL: One

EQUIPMENT CONDITION: Truck parked, engine off, handbrake set, rear wheels chocked.

a. Preliminary Procedure. Jack up truck. Put safety jacks under frame. Refer to Part 1, para 11-3.

b. Removal.

FRAME 1

1. Using wrench, hold nut (1). Using 5/8-inch wrench, unscrew and take off nut (2). Using wrench, unscrew and take off nut (1).
2. Take off retainer (3) and rubber bushing (4).
3. Push end of shock absorber (5) out of hole in plate (6). Take off rubber bushing (7) and retainer (8).

GO TO FRAME 2

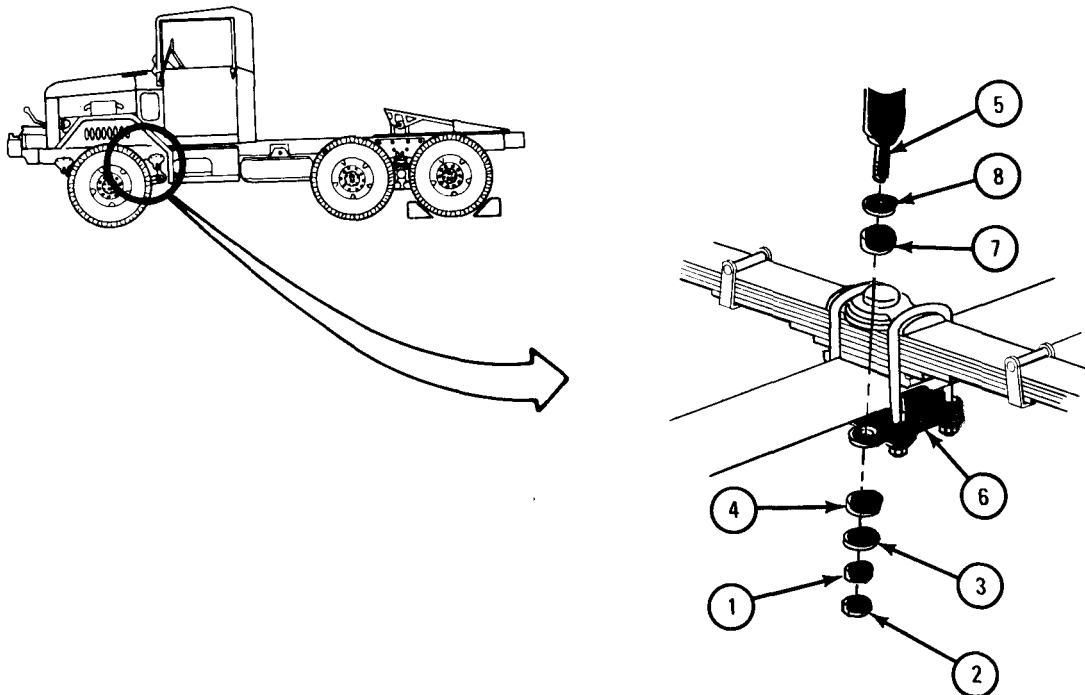

TA 046280

FRAME 2

1. Using wrench, hold nut (1). Using wrench, unscrew and take off nut (2).
Using wrench, unscrew and take off nut (1).
2. Take off retainer (3) and rubber bushing (4).
3. Pull shock absorber (5) out of hole in bracket (6).
4. Take off rubber bushing (7) and retainer (8).

END OF TASK

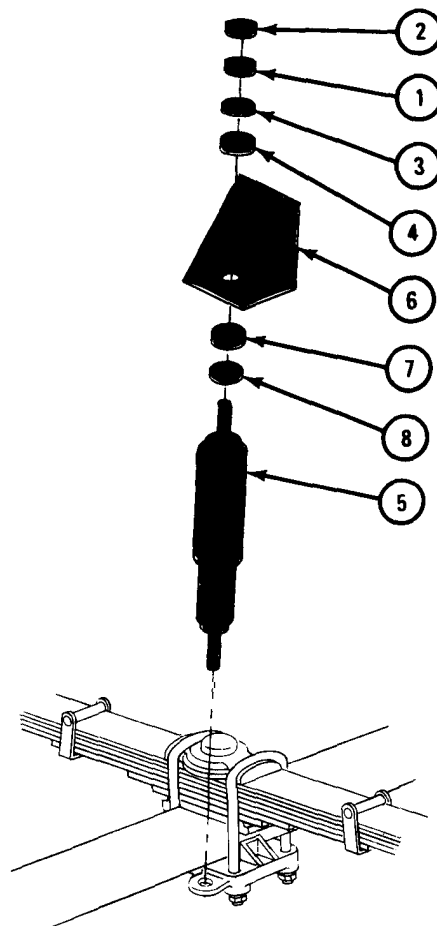

TA 046281

c. Replacement.

FRAME 1

1. Find larger end of shock absorber (1). Put retainer (2) and rubber bushing (3) on screw on that end. Put screw through hole in bracket (4).
2. Put rubber bushing (5) and retainer (6) on screw. Using wrench, screw on and tighten nut (7). Using wrench, screw on and tighten nut (8).

GO TO FRAME 2

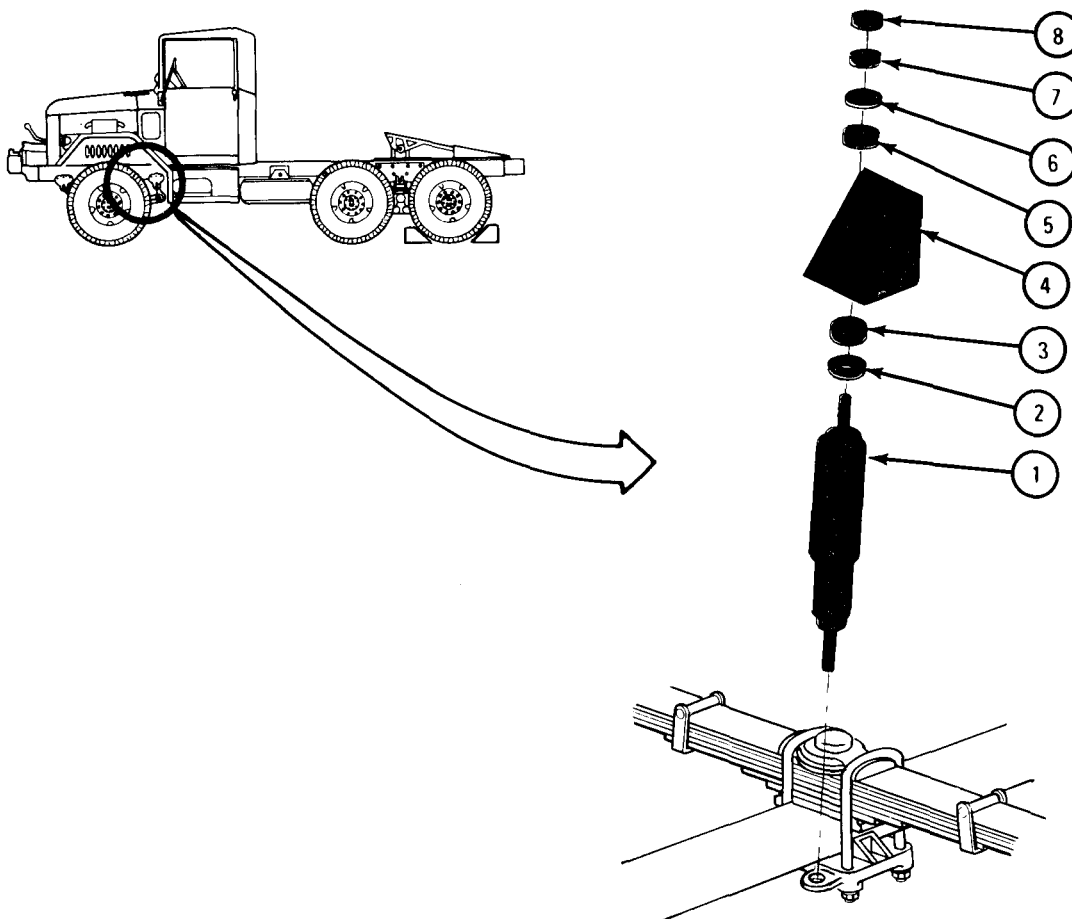

TA 046282

FRAME 2

1. Put retainer (1) and rubber bushing (2) on screw of shock absorber (3). Pull down small end of shock absorber and put screw into hole in plate (4).
2. Put on rubber bushing (5) and retainer (6). Using wrench, screw on and tighten nut (7). Using wrench, screw on and tighten nut (8).

NOTE

Follow-on Maintenance Action Required:

Take safety jacks away. Jack truck down. Refer to Part 1, para 11-3.

END OF TASK

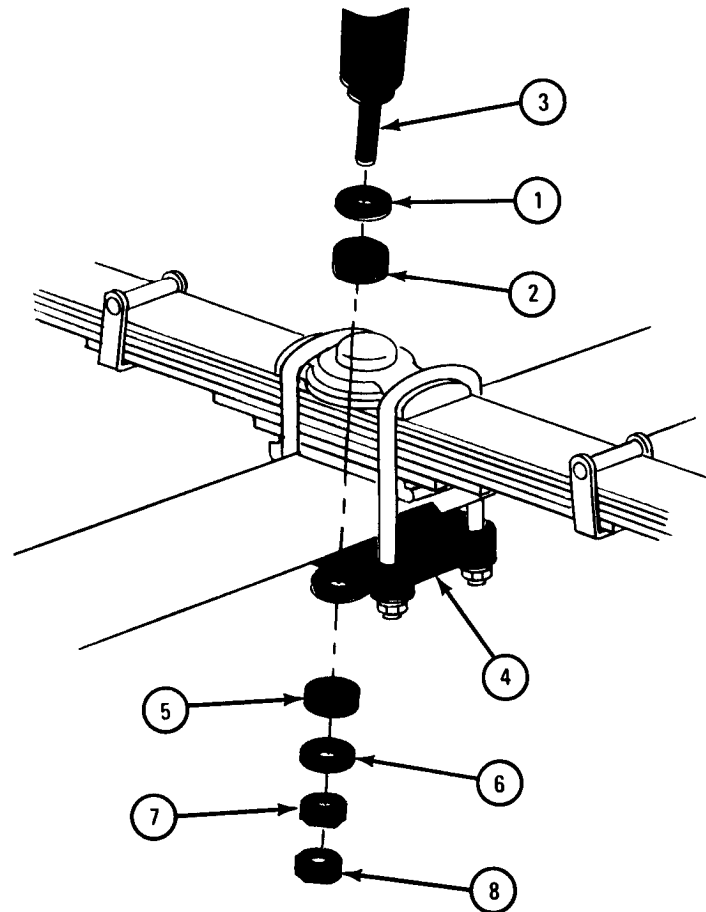

TA 046283

Section IV. TORQUE RODS

17-12. TORQUE RODS REMOVAL AND REPLACEMENT.

TOOLS:	1 7/16-inch deep socket wrench	Socket handle
	2 x 30-inches round steel stock	10-pound sledge hammer
	6-inch diagonal cutting pliers	7/16-inch wrench (2)
	1 7/16-inch crow foot adapter	Flat-tip screwdriver
	Torque wrench, 600 pound-feet capacity	

SUPPLIES: None

PERSONNEL: Two

EQUIPMENT CONDITION: Truck parked, engine off, handbrake set, front wheels chocked.

a. Preliminary Procedures.

(1) Jack up and support rear axle housings. Refer to Part 1, para 11-3.

(2) Remove all rear wheels. Refer to TM 9-2320-209-10.

(3) Take off left side spring saddle to remove upper torque rods on left side of truck. Refer to para 17-8.

b. Removal.

FRAME 1

Soldier A 1. Using 3/8-inch wrenches and screwdriver, unscrew and take off four capscrews (1) and nuts (2). Spread open and take off four clamps (3) holding two brake lines (4) on two upper torque rods (5).

NOTE

On some trucks, there may be plastic ties holding two brake lines (4) to upper torque rods (5). Using diagonal cutting pliers, cut off four ties.

- 2. Using 1 7/16-inch socket wrench, unscrew two nuts (6) until outer side of nut is even with end of upper torque rod end (7).
- 3. Hold end of steel punch against end of upper torque rod end (7).

Soldier B 4. Using sledge hammer, hit end of punch to loosen upper torque rod end (7).

Soldier A 5. Using 1 7/16-inch socket wrench, unscrew and take off two nuts (6).

GO TO FRAME 2

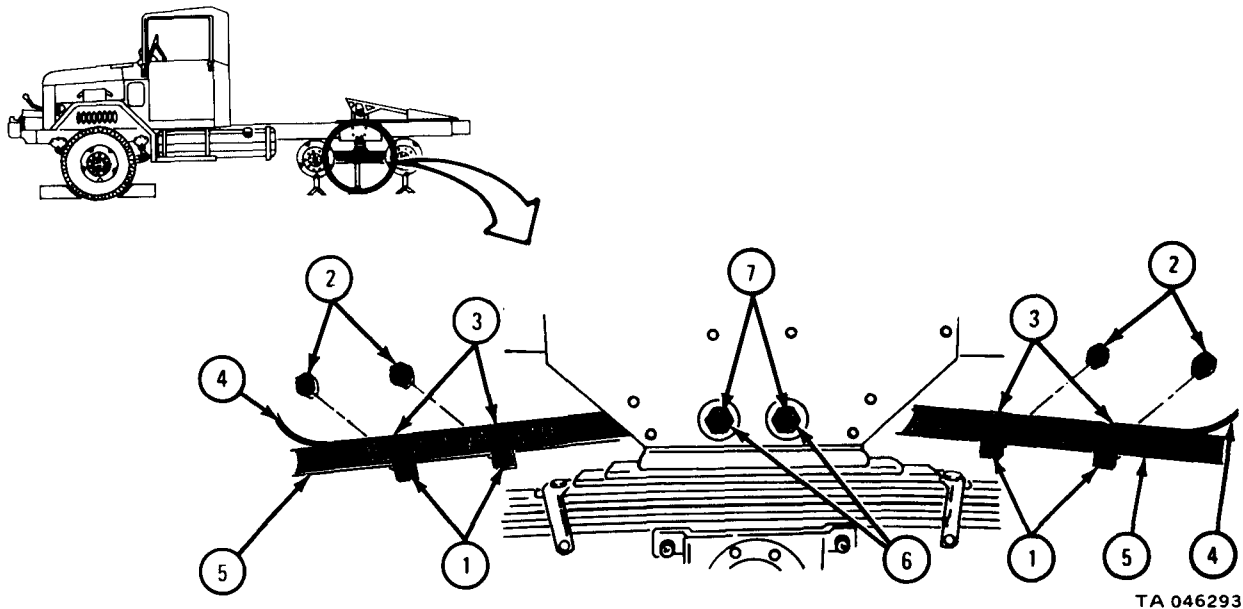

FRAME 2

1. Using 1 7/16-inch wrench, unscrew and take off three nuts (1) and lockwashers (2).
2. Using sledge hammer, hit three brackets at point (3) until two torque rods (4) and upper torque rod (5) are loose.
3. Take off upper torque rod (5).

GO TO FRAME 3

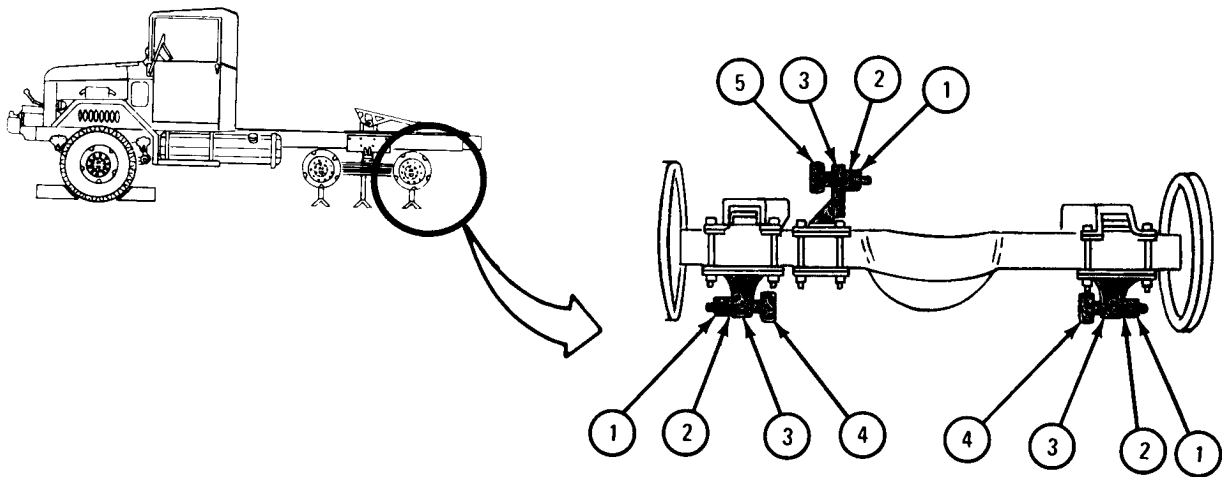

TA 046294

FRAME 3

1. Using 1 7/16-inch wrench, Unscrew and take off three nuts (1) and lockwashers (2).
2. Using sledge hammer, hit three brackets at points (3) until two torque rods (4) and upper torque rod (5) are loose.
3. Take off upper torque rod (5).

GO TO FRAME 4

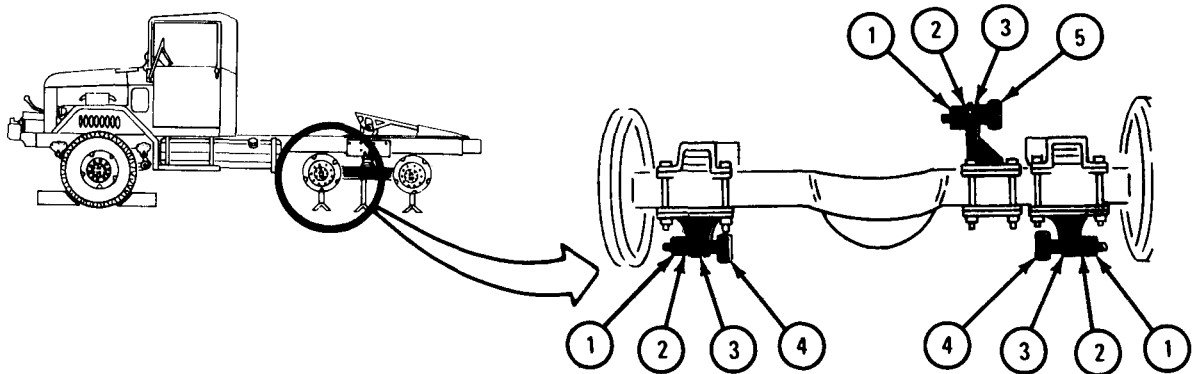

TA 046295

FRAME 4

1. Working under truck at left side and using 1 7/16-inch socket wrench, loosen two nuts (1) until they are even with two torque rod ends (2).
2. Using sledge hammer, hit two torque rod ends (2) until they are loose.
3. Using 1 7/16-inch socket wrench, unscrew and take off two nuts and lockwashers (1).
4. Take off two torque rods (3).
5. Do steps 1, 2, and 3 again to take off two torque rods (3) on right side of truck.

END OF TASK

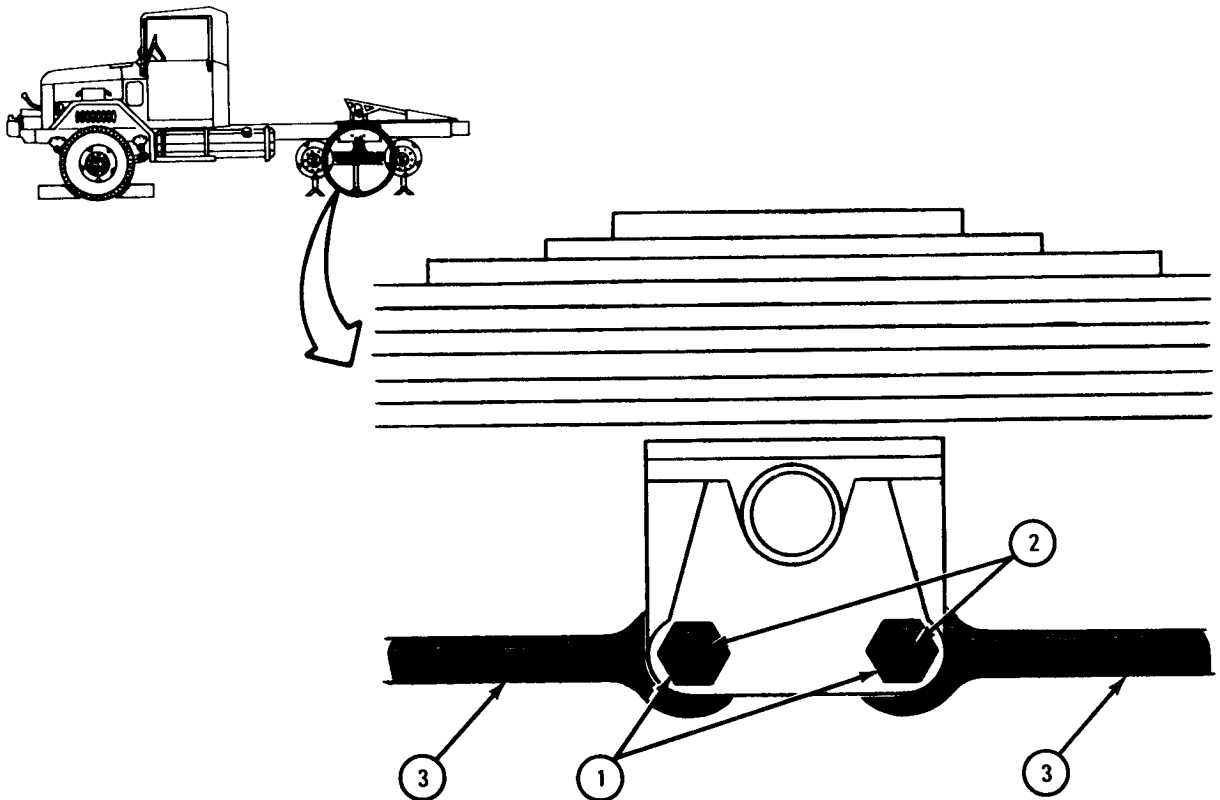

TA 046296

c. Replacement.

FRAME 1

1. Working under truck at left side, put ends of torque rods (1 and 2) into two holes in bracket (3). Screw threads should point away from spring (4).
2. Put other end of torque rod (1) into bracket (5) on rear-rear axle. Put other end of torque rod (2) into bracket (5) on forward-rear axle.
3. Using sledge hammer, tap ends of two torque rods (1 and 2) into brackets (3 and 5). Using 1 7/16-inch socket wrench, screw on four lockwashers (6) and nuts (7).
4. Using torque wrench with 1 7/16-inch socket, tighten four nuts (7) to 350 to 400 pound-feet.

GO TO FRAME 2

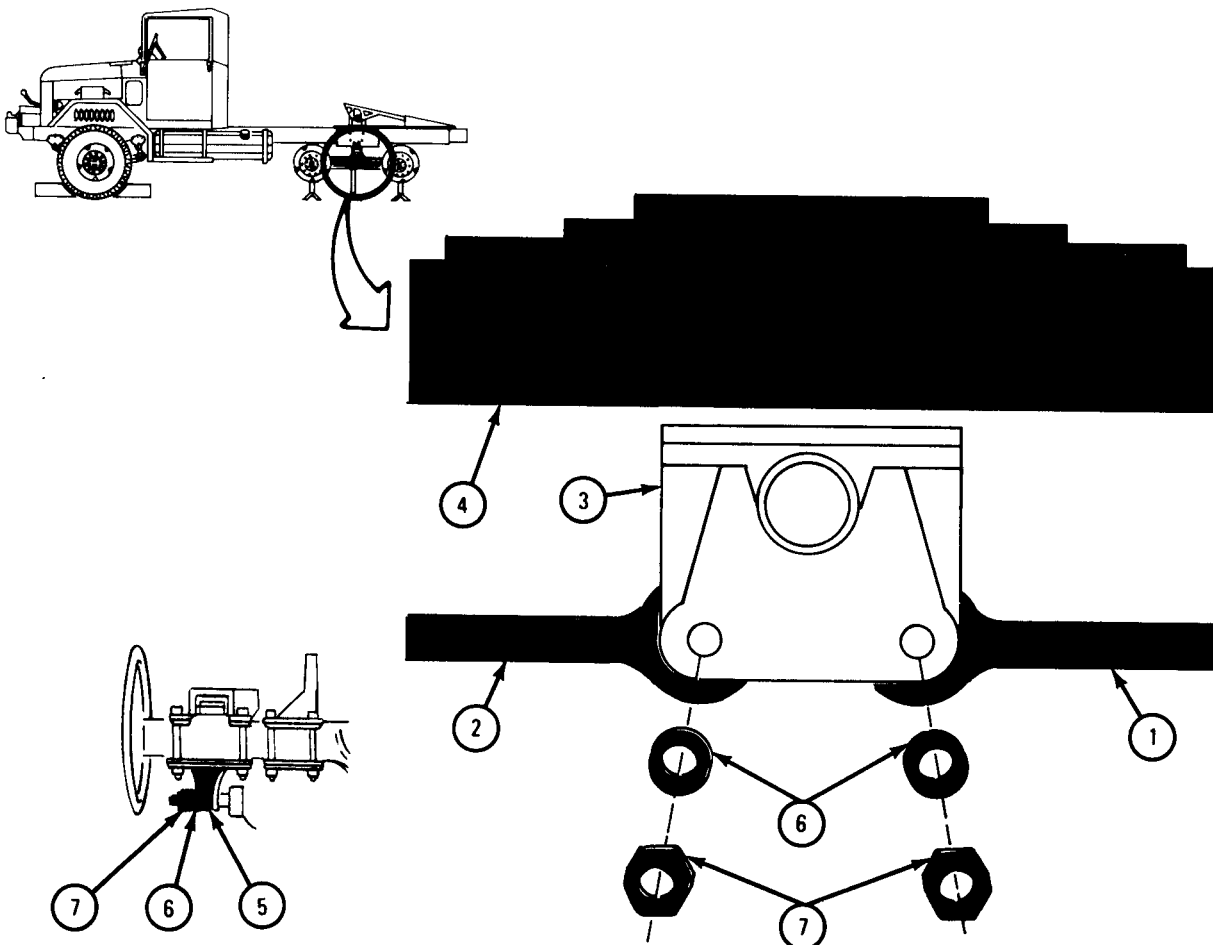

TA 046297

FRAME 2

1. Put ends of two upper torque rods (1 and 2) into holes in bracket (3).
2. Put other end of torque rod (1) into holes in bracket (4) on forward-rear axle. Put other end of torque rod (2) in bracket (4) on rear-rear axle.
3. Using sledge hammer, tap four ends of torque rods (1 and 2) into brackets (3 and 4).
4. Using 1 7/16-inch socket wrench, screw on two lockwashers (5) and nuts (6), and two lockwashers (7) and nuts (8).
5. Using torque wrench with 1 7/16-inch socket, tighten two nuts (6) to 350 to 400 pound-feet.
6. Using torque wrench with 1 7/16-inch crow foot adapter, tighten nut (8) to 350 to 400 pound-feet.

GO TO FRAME 3

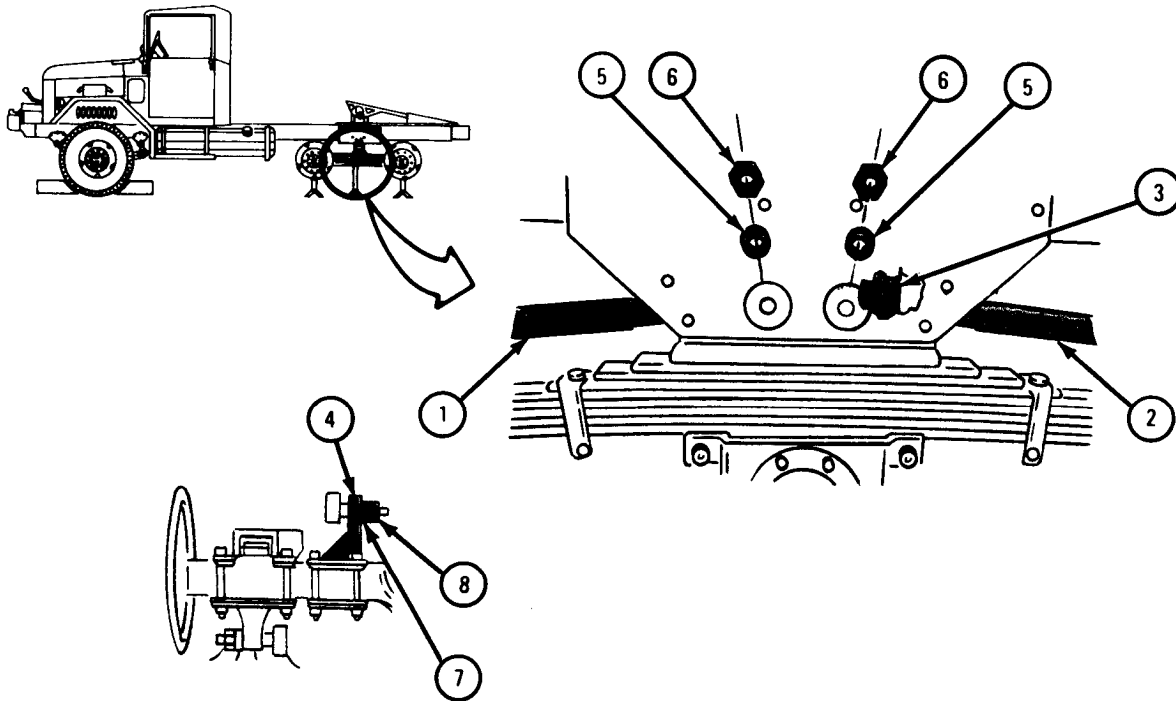

TA 046299

FRAME 3

NOTE

If four plastic ties holding brake lines on torque rods were taken off, put on new plastic ties.

1. Put four clamps (1) holding two brake lines (2) on two upper torque rods (3).
2. Using 7/16-inch wrenches, screw on and tighten four capscrews (4) and four nuts (5).

NOTE

Follow-on Maintenance Action Required:

1. Replace left side spring saddle. Refer to para 17-8.
2. Replace all rear wheels. Refer to TM 9-2320-209-10.
3. Lower rear axle housings. Refer to para 11-3.

END OF TASK

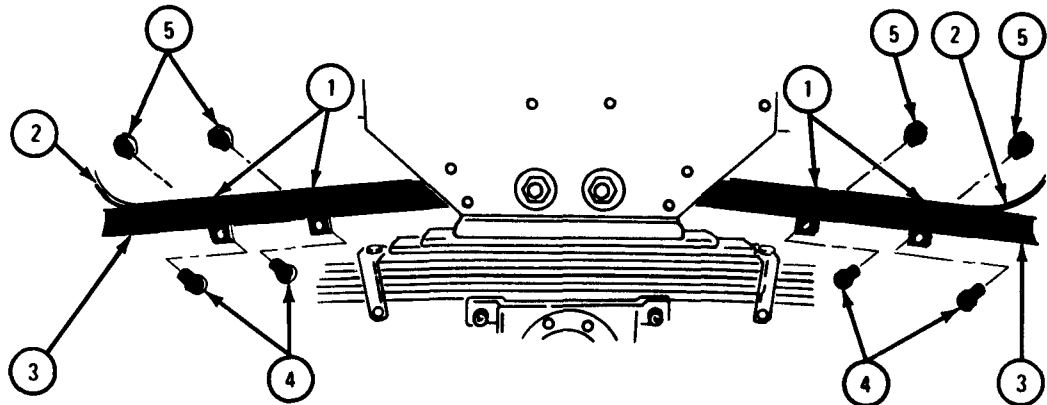
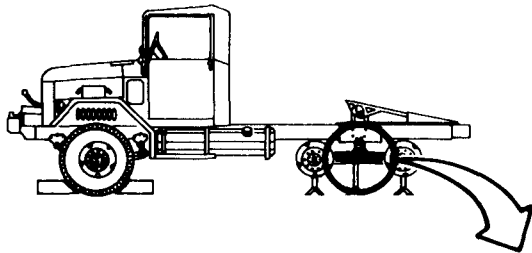

TA 085545

By Order of the Secretaries of the Army and the Air Force:

E. C. MEYER
General, United States Army
Chief of Staff

Official:

J. C. PENNINGTON
Major General, United States Army
The Adjutant General

LEW ALLEN, JR., General, USAF
Chief of Staff

Official:

VAN L. CRAWFORD, JR., Colonel, USAF
Director of Administration

Distribution:

To be distributed in accordance with DA Form 12-38, Organizational Maintenance requirements for 2-1/2-Ton Truck Cargo, 2-1/2-Ton Truck Van, etc.



THEN... JOT DOWN THE DOPE ABOUT IT ON THIS FORM, CAREFULLY TEAR IT OUT, FOLD IT AND DROP IT IN THE MAIL!

SOMETHING WRONG WITH THIS PUBLICATION?

FROM: (PRINT YOUR UNIT'S COMPLETE ADDRESS)

CDR, 1st Bn, 65th ADA
Attn: SP4 Jane Idone
Key West, FL 33040

DATE SENT

Date Sent In

PUBLICATION NUMBER

TM 9-2320-209-20-3-2

PUBLICATION DATE

27 May 81

PUBLICATION TITLE

ORGANIZATIONAL MAINTENANCE MANUAL

BE EXACT... PIN-POINT WHERE IT IS

PAGE NO	PARA-GRAPH	FIGURE NO	TABLE NO
13-83	13-12 b		
17-3	17-3 a		
17-37	17-7 d		

IN THIS SPACE TELL WHAT IS WRONG AND WHAT SHOULD BE DONE ABOUT IT:

FRAME 1, step 3 reads "Screw in capscrew and washer (4)." Should read "Reach over top of master cylinder (1) and screw in capscrew and lockwasher (4)."

FRAME 2 - Change illustration callouts. Reason: callouts for rubber bushing (7) and retainer (8) are reversed.

FRAME 2, step 1 of follow-on Maintenance Action refers to para 1-76. Should refer to para 17-6.

SAMPLE

PRINTED NAME GRADE OR TITLE AND TELEPHONE NUMBER

SP4 Jane Idone Autovon 222-2224

SIGN HERE

Jane Idone

FILL IN YOUR
UNIT'S ADDRESS



FOL

DEPARTMENT OF THE ARMY

OFFICIAL BUSINESS
PENALTY FOR PRIVATE USE \$.

SAMPLE

POSTAGE AND FEES PAID
DEPARTMENT OF THE ARMY
DOD 314



TEAR ALONG PERFORATED LINE

Commander
U.S. Army Tank-Automotive Command
ATTN: DRSTA-MB
Warren, MI 48090

RECOMMENDED CHANGES TO EQUIPMENT TECHNICAL PUBLICATIONS

SOMETHING WRONG WITH THIS PUBLICATION?



THEN... JOT DOWN THE DOPE ABOUT IT ON THIS FORM. CAREFULLY TEAR IT OUT, FOLD IT AND DROP IT IN THE MAIL.

FROM (PRINT YOUR UNIT'S COMPLETE ADDRESS)

DATE SENT

PUBLICATION NUMBER

TM 9-2320-209-20-3-2

PUBLICATION DATE

27 May 81

PUBLICATION TITLE

ORGANIZATIONAL MAINTENANCE MANUAL

BE EXACT PIN-POINT WHERE IT IS

PAGE NO

PARA-GRAPH

FIGURE NO

TABLE NO

IN THIS SPACE TELL WHAT IS WRONG AND WHAT SHOULD BE DONE ABOUT IT:

PRINTED NAME GRADE OR TITLE AND TELEPHONE NUMBER

SIGN HERE

FILL IN YOUR
UNIT'S ADDRESS

FOLD BACK

DEPARTMENT OF THE ARMY

POSTAGE AND FEES PAID
DEPARTMENT OF THE ARMY
DOD 314



OFFICIAL BUSINESS
PENALTY FOR PRIVATE USE \$300

TEAR ALONG PERFORATED LINE

Commander
U.S. Army Tank-Automotive Command
ATTN: DRSTA-MB
Warren, MI 48090

RECOMMENDED CHANGES TO EQUIPMENT TECHNICAL PUBLICATIONS



THEN... JOT DOWN THE DOPE ABOUT IT ON THIS FORM. CAREFULLY TEAR IT OUT. FOLD IT AND DROP IT IN THE MAIL.

SOMETHING WRONG WITH THIS PUBLICATION?

FROM (PRINT YOUR UNIT'S COMPLETE ADDRESS)

DATE SENT

PUBLICATION NUMBER

TM 9-2320-209-20-3-2

PUBLICATION DATE

27 May 81

PUBLICATION TITLE

ORGANIZATIONAL MAINTENANCE MANUAL

BE EXACT PIN-POINT WHERE IT IS

PAGE NO	PARA-GRAPH	FIGURE NO	TABLE NO

IN THIS SPACE TELL WHAT IS WRONG AND WHAT SHOULD BE DONE ABOUT IT:

PRINTED NAME GRADE OR TITLE AND TELEPHONE NUMBER

SIGN HERE

FILL IN YOUR
UNIT'S ADDRESS

FOLD BACK

DEPARTMENT OF THE ARMY

POSTAGE AND FEES PAID
DEPARTMENT OF THE ARMY
DOD 314



TEAR ALONG PERFORATED LINE

OFFICIAL BUSINESS
PENALTY FOR PRIVATE USE \$300

Commander
U.S. Army Tank-Automotive Command
ATTN: DRSTA-MB
Warren, MI 48090

RECOMMENDED CHANGES TO EQUIPMENT TECHNICAL PUBLICATIONS



THEN... JOT DOWN THE DOPE ABOUT IT ON THIS FORM, CAREFULLY TEAR IT OUT, FOLD IT AND DROP IT IN THE MAIL!

SOMETHING WRONG WITH THIS PUBLICATION?

FROM (PRINT YOUR UNIT'S COMPLETE ADDRESS)

DATE SENT

PUBLICATION NUMBER

TM 9-2320-209-20-3-2

PUBLICATION DATE

27 May 81

PUBLICATION TITLE

ORGANIZATIONAL MAINTENANCE MANUAL

BE EXACT... PIN-POINT WHERE IT IS

PAGE NO

PARA-GRAPH

FIGURE NO

TABLE NO

IN THIS SPACE TELL WHAT IS WRONG AND WHAT SHOULD BE DONE ABOUT IT:

PRINTED NAME GRADE OR TITLE AND TELEPHONE NUMBER

SIGN HERE

FILL IN YOUR
UNIT'S ADDRESS

FOLD BACK

DEPARTMENT OF THE ARMY

OFFICIAL BUSINESS
PENALTY FOR PRIVATE USE \$300

POSTAGE AND FEES PAID
DEPARTMENT OF THE ARMY
DOD 314



TEAR ALONG PERFORATED LINE

Commander
U.S. Army Tank-Automotive Command
ATTN: DRSTA-MB
Warren, MI 48090

THE METRIC SYSTEM AND EQUIVALENTS

LINEAR MEASURE

1 Centimeter ≈ 10 Millimeters = 0.01 Meters = 0.3937 Inches
 1 Meter = 100 Centimeters = 1000 Millimeters = 39.37 Inches
 1 Kilometer = 1000 Meters = 0.621 Miles

SQUARE MEASURE

1 Sq Centimeter ≈ 100 Sq Millimeters = 0.155 Sq Inches
 1 Sq Meter = 10,000 Sq Centimeters = 10.76 Sq Feet
 1 Sq Kilometer = 1,000,000 Sq Meters = 0.386 Sq Miles

WEIGHTS

1 Gram = 0.001 Kilograms = 1000 Milligrams = 0.035 Ounces
 1 Kilogram = 1000 Grams = 2.2 Lb
 1 Metric Ton = 1000 Kilograms = 1 Megagram = 1.1 Short Tons

CUBIC MEASURE

1 Cu Centimeter = 1000 Cu Millimeters = 0.06 Cu Inches
 1 Cu Meter = 1,000,000 Cu Centimeters = 35.31 Cu Feet

LIQUID MEASURE

1 Milliliter = 0.001 Liters = 0.0338 Fluid Ounces
 1 Liter = 1000 Milliliters = 33.82 Fluid Ounces

TEMPERATURE

$5/9 (^{\circ}\text{F} - 32) = ^{\circ}\text{C}$
 212^o Fahrenheit is equivalent to 100^o Celsius
 90^o Fahrenheit is equivalent to 32.2^o Celsius
 32^o Fahrenheit is equivalent to 0^o Celsius
 $9/5 \text{ C}^{\circ} + 32 = \text{F}^{\circ}$

APPROXIMATE CONVERSION FACTORS

<u>TO CHANGE</u>	<u>TO</u>	<u>MULTIPLY BY</u>
Inches	Centimeters	2.540
Feet	Meters	0.305
Yards	Meters	0.914
Miles	Kilometers	1.609
Square Inches	Square Centimeters	6.451
Square Feet	Square Meters	0.093
Square Yards	Square Meters	0.836
Square Miles	Square Kilometers	2.590
Acres	Square Hectometers	0.405
Cubic Feet	Cubic Meters	0.028
Cubic Yards	Cubic Meters	0.765
Fluid Ounces	Milliliters	29.573
Pints	Liters	0.473
Quarts	Liters	0.946
Gallons	Liters	3.785
Ounces	Grams	28.349
Pounds	Kilograms	0.454
Short Tons	Metric Tons	0.907
Pound-Feet	Newton-Meters	1.356
Pounds per Square Inch	Kilopascals	6.895
Miles per Gallon	Kilometers per Liter	0.425
Miles per Hour	Kilometers per Hour	1.609

<u>TO CHANGE</u>	<u>TO</u>	<u>MULTIPLY BY</u>
Centimeters	Inches	0.394
Meters	Feet	3.280
Meters	Yards	1.094
Kilometers	Miles	0.621
Square Centimeters	Square Inches	0.155
Square Meters	Square Feet	10.764
Square Meters	Square Yards	1.196
Square Kilometers	Square Miles	0.386
Square Hectometers	Acres	2.471
Cubic Meters	Cubic Feet	35.315
Cubic Meters	Cubic Yards	1.308
Milliliters	Fluid Ounces	0.034
Liters	Pints	2.113
Liters	Quarts	1.057
Liters	Gallons	0.264
Grams	Ounces	0.035
Kilograms	Pounds	2.205
Metric Tons	Short Tons	1.102
Newton-Meters	Pound-Feet	0.738
Kilopascals	Pounds per Square Inch	0.145
Kilometers per Liter	Miles per Gallon	2.354
Kilometers per Hour	Miles per Hour	0.621

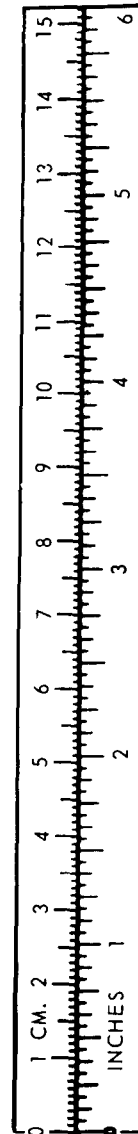

TAO89991

